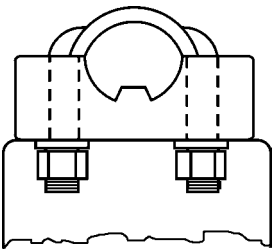
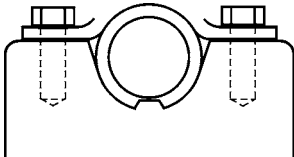
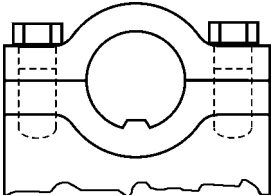

U-Bolt	Series	Spicer® Kit Number	Spicer® U-Bolt Assy	Recommended Bolt Torque
	1280	5-200X	2-94-28X	14-17 Lb. Ft.
	1310/SPL22	5-153X	2-94-28X	14-17 Lb. Ft.
	1330/SPL25	5-213X	2-94-28X	14-17 Lb. Ft.
	1350/SPL30	5-178X	3-94-18X	20-24 Lb. Ft.
	1410/SPL36	5-160X	3-94-18X	20-24 Lb. Ft.
	1480/SPL55	5-188X	3-94-28X	32-37 Lb. Ft.
	1550/SPL70	5-155X	3-94-28X	32-37 Lb. Ft.
Bearing Strap	Series	Spicer® Kit Number	Spicer® Strap Kit Assy	Recommended Bolt Torque
	SPL90	SPL90X	90-70-28X	45-60 Lb. Ft.
	1210	5-443X	2-70-18X	13-18 Lb. Ft.
	1280	5-200X	2-70-18X	13-18 Lb. Ft.
	1310/SPL22	5-153X	2-70-18X	13-18 Lb. Ft.
	1330/SPL25	5-213X	2-70-18X	13-18 Lb. Ft.
	3R/S44	5-3147X	2-70-48X	30-35 Lb. Ft.
	1350/SPL30	5-178X	3-70-28X	30-35 Lb. Ft.
	1350SPEC ♦		2-70-48X	25-30 Lb. Ft.
	1410/SPL36	5-160X	3-70-28X	30-35 Lb. Ft.
	1480/SPL55	5-188X	3-70-38X	55-60 Lb. Ft.
	1550/SPL70	5-155X	3-70-38X	55-60 Lb. Ft.
	1610	5-438X	5-70-28X	55-60 Lb. Ft.
	1710	5-515X	6.5-70-18X	130-135 Lb. Ft.
	1710	5-515X	212214X■	130-135 Lb. Ft.
	1760	5-469X	6.5-70-18X	130-135 Lb. Ft.
	1760	5-469X	212214X■	130-135 Lb. Ft.
	1810	5-510X	6.5-70-18X	130-135 Lb. Ft.
	1810	5-510X	212214X■	130-135 Lb. Ft.
Cap & Bolt	Series	Spicer® Kit Number	Spicer® Cap & Bolt Assy	Recommended Bolt Torque
	1650	5-165X	5-70-18X	77-103 Lb. Ft.
	1850	5-185X	8-70-18X	110-147 Lb. Ft.
	1850	5-227X	8-70-18X	110-147 Lb. Ft.
	1910◀	5-316X	N.S.S.	110-147 Lb. Ft.
	1950◀	5-339X	9-70-18X	271-362 Lb. Ft.
	2010◀	5-371X	N.S.S.	102-118 Lb. Ft.
	2050◀	5-340X	9-70-28X	744-844 Lb. Ft.
	2110◀	5-372X	N.S.S.	171-197 Lb. Ft.
	2150◀	5-298X	9-70-38X	744-844 Lb. Ft.
	2210◀	5-373X	N.S.S.	260-298 Lb. Ft.

♦ Strap kit 1350 Series "Special" for Corvette with metric bolts 3-70-48X also fits some Dodge Viper.

■ Kit has "cast" style strap

◀ For reference only; these driveline series are not serviced by Dana Spicer Service Parts

Bearing Plate

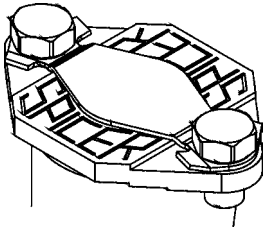

Warning: Self locking bolts should **NOT** be reused

Series	Spicer® Kit Number	Bolt Part Number	Lockstrap Part Number	Recommended Bolt Torque
1610	*5-279X	5-73-709	N.A.	26-35 Lb. Ft.
1710	*5-280X	6-73-209	N.A.	38-48 Lb. Ft.
1760	*5-407X	6-73-209	N.A.	38-48 Lb. Ft.
1810	*5-281X	6-73-209	N.A.	38-48 Lb. Ft.
1880	*5-308X	7-73-315	N.A.	60-70 Lb. Ft.
1610	5-654X	5-73-109	98-1741	17-24 Lb. Ft.
1710	5-656X	6-73-109	230323	32-42 Lb. Ft.
1760	5-658X	6-73-109	230323	32-42 Lb. Ft.
1810	5-660X	6-73-109	230323	32-42 Lb. Ft.
1880	5-668X	7-73-115	231009	50-66 Lb. Ft.

*these kits use self-locking bolts with lock patch.

MSC

Series	Spicer® Kit Number	Spicer® Strap Kit Assy	OLD "Yellow/Gold" Attaching Bolt Part Number	Recommended Bolt Torque	NEW "Green" Attaching Bolt Part Number	Recommended Bolt Torque
SPL140	SPL140X	140-70-18X	12-73-125M	100-120 Lb. Ft.	5007417	115-135 Lb. Ft.
SPL170	SPL170X	170-70-18X	12-73-125M	100-120 Lb. Ft.	5007417	115-135 Lb. Ft.
SPL250	SPL250X	250-70-18X	12-73-125M	100-120 Lb. Ft.	5007417	115-135 Lb. Ft.

Originally SPL140 and SPL250 Series bearing retainer and u-joint kits included bolt part number 12-73-125M, which is YELLOW/GOLD in color. The newer bolt part number, 5007417, is GREEN in color. This was a running change that began in the second quarter of 2006.