

Air Springs

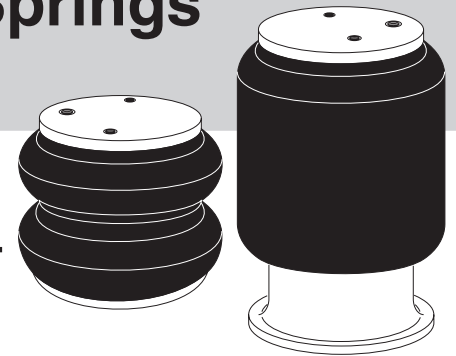

PRODUCT EMPHASIS PROGRAM

How do air suspensions work?

Most air suspensions consist of a series of rubber air springs that are fastened between the frame and a rigid or flexible trailing arm. Air pressure inside the spring is adjusted for a desired ride height. In response to changing load and road conditions, air spring bellows extend and compress. Because of this movement a height control valve is activated channeling air into the springs to maintain the proper chassis ride height.

Axle load distribution on tandem suspensions is achieved by passing air between front and rear springs. The air passing between springs provides a major source of damping, as the air springs themselves dissipate very little energy.

Shock absorbers are an integral part of all air suspensions. The shock's function is to protect the air spring by absorbing impacts and restrict overall suspension travel. Shock absorbers extend suspension and air spring life and keep tires in contact with the road for greater driver control.

Types of air springs

Two basic types of air springs are utilized in modern air suspension systems:

Rolling Lobe or Reversible Sleeve — (figure 1), Flexible member rolls up and down a smooth piston surface to vary height and absorb road shocks. Most replacement work will involve this design.

Convoluted Design — (figure 2), Bellows flex in and out to vary height and absorb road shocks.

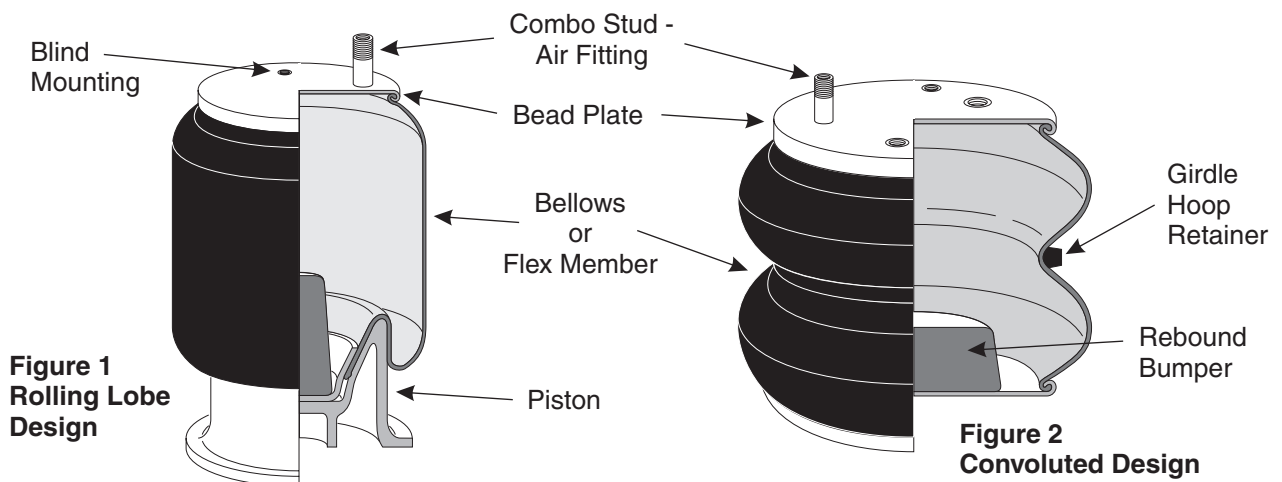

Figure 1
Rolling Lobe
Design

Figure 2
Convoluted Design

Technical Information

Troubleshooting an air control system

Although air suspensions have proven to be quite dependable, no heavy duty system is immune to wearing out or suffering premature failure. Unlike steel leaf springs, diagnosing an air spring problem takes a little more effort than looking for a cracked leaf. While each suspension has some unique service procedures, there are some problems which are common to all air suspension. A quick reference guide to troubleshooting those associated with the air control system are shown below.

The leveling valve has an important role to play in the proper operation of an air suspension. It needs clean dry air to perform properly. Air line filters should be changed once per year and the air cleaner should be drained of dirt and moisture monthly.

Problem	Possible Cause	Corrections
Air Spring Flat On One Side Of The Vehicle Only.	Air spring(s) leaking air.	Visually inspect the air spring(s) for leaks resulting from damage, wear or deterioration. If any spring is leaking, replace with proper part.
	Air leakage between the height control valve and the air spring(s).	Listen for leakage due to loose fittings or damaged air lines. Tighten loose fittings to stop leakage and/or replace damaged air lines with new ones.
	Bent, broken or disconnected height control valve linkage.	Visually inspect the linkage for damaged or loose parts. Reconnect loose linkage parts and/or replace defective parts with new ones.
	Height control valve out of adjustment.	Disconnect the height control valve actuating lever from the height control valve linkage. Move the lever upward, if the air spring then inflates, adjust the height control valve(s).
	Inoperative height control valve.	If movement of the actuating lever in the above step fails to inflate the air spring or continually leaks air through the exhaust port in the neutral position, the height control valve must be replaced.
All Air Springs Flat (No Air)	Defective pressure protection valve.	Replace
	Air leakage between the suspension air system or the air brake system.	Listen for leakage due to loose fittings or control valves. Tighten loose fittings to stop leakage and/or replace worn or damaged parts with new ones.
	Insufficient air pressure in the vehicle air system.	Check the air pressure gauge on the instrument panel. If air pressure is low, run the engine until a minimum pressure of 65 psi is indicated on the gauge.
Tractor Ride Height Too High Or Too Low	Height control valve(s) out of adjustment.	Readjust the height control valve(s).
Air Springs Deflate Rapidly When Vehicle Is Parked.	Air leakage from the suspension system.	Listen for air leakage due to loose fittings between air tank and air suspension or damaged air lines, air springs or height control valves. Tighten loose fittings to stop leakage and/or replace worn or damaged parts with new ones.

Quick Height Control Valve Adjustment

- Vehicle must be on level ground with brakes released.
- Most vehicles ride height is measured from bottom of frame to the ground. Average ride heights are between 34" and 34 1/4".
- Some OEM's specify ride height values measured differently than above. Neway specs are measured from frame to axle center, Peterbilt from frame to air spring base. When referring to OE specifications, be sure to confirm measurement reference points.
- Install dowels into top and bottom holes in the leveling valve. Discharge air. When air is exhausted, remove the linkage.
- Jack frame to 34"- 34 1/4". Note: This is a generally accepted ride height specification. Manufacturers' specifications always take precedence.
- Replace linkage. Adjust so HCV lever is in the center of its operating range.
- Remove dowels, lower vehicle and charge system. The vehicle should be at the proper height. If not, check for bent or defective linkage. Check air system and HCV. Repair or replace as required. Most suspensions operate at 84 - 90 psi, check with an inline pressure gauge.

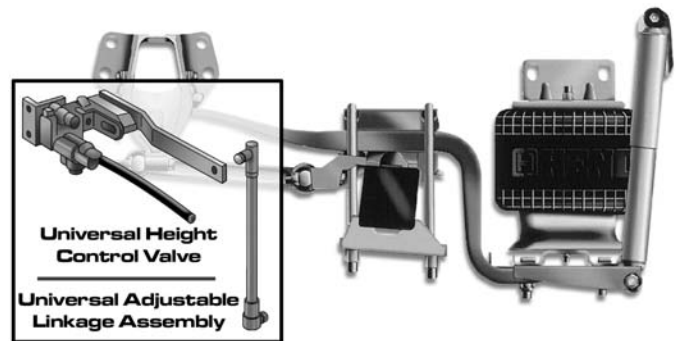

Technical Information *(continued)*

Air spring failures

While service life of the air spring itself varies due to differences in suspension design or operating environment, useful life is usually measured in several hundred thousand miles. Failure of an air spring is considered to be when the spring will no longer hold sufficient air pressure to perform its function in the suspension system. Typically, leaks occur in the flex member or bellows where contaminants cause deterioration of the rubber.

Misapplication, suspension misalignment, bottoming, overextension, abrasion, excessive or insufficient air pressure and physical damage usually cause premature air spring failures. These failures are considered abnormal and preventable.



Misalignment

- Worn bushings
- Improper suspension installation

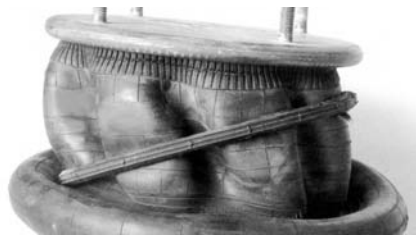

Loose Girdle Hoop

- Running at extended positions with low air pressure



Cuts

- High pressure, fully extended for long periods
- Impact in compressed position



Abrasion

- Interference
 - Broken shock
 - Loose air line
 - Misalignment
 - Worn bushings
- No air pressure
- Debris sand, rocks, rust, etc.
- Wrong spring

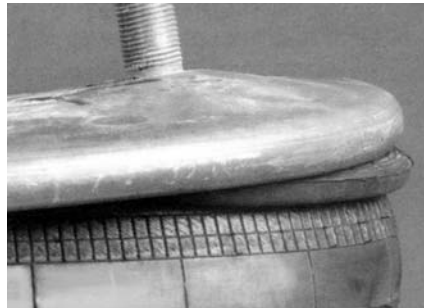

Over Extension

- Broken or wrong shock absorber
- Defective height control valve
- Ride height set too high
- Defective stop position (Lift axles)
- Wrong spring (too short)

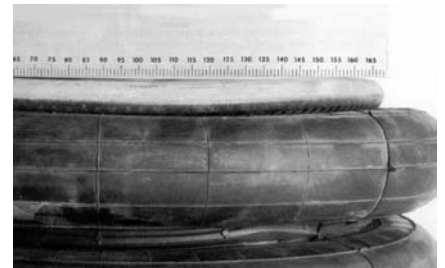

Bottoming

- Broken or defective shock absorber
- Defective leveling valve
- Overloaded vehicle
- Improper pressure regulator adjustment
- Wrong air spring (too tall)

Air Suspension Maintenance Tips

- Protect you air suspension investment by specifying replacement air springs that meet or exceed original equipment standards. Dayton Parts air springs meet the test.
- Replace all air springs on an axle (carry old serviceable air spring as a spare).
- Use only compatible pistons and flex members.



Preventative Maintenance Check List

A properly maintained air suspension system offers a greater level of isolation, reducing vibration and road shock translated to the vehicle and freight. This extends component life, reduces driver fatigue, down time and cargo damage.



- Check for properly functioning height control valve.
- Inspect OD of air spring for irregular wear or heat damage.
- Inspect clearance between airlines and springs.
- Inspect for sufficient clearance around air spring's complete diameter. Check while spring is at its maximum diameter. (Generally, 1 ½" minimum clearance is acceptable to allow for diameter expansion during suspension jounce.)
- Inspect pistons and bead plates for build up of foreign materials (road debris, corrosion etc.) Clean only with soap and water. Do not use petroleum solvents, flame, abrasives or pressurized steam cleaning methods.
- Check for proper ride height as specified by the OEM. Ride height should be within + or - ¼" of specification.
- Check for properly functioning shock absorbers. Look for broken, leaking or worn shocks. Be sure vehicle is equipped with the proper shock absorber.
- Check the tightness of all mounting hardware. Torque to OEM specifications — Do Not Over Tighten. See air spring catalog for general recommendations.
- Inspect trailing arm and torque rod bushings for wear and misalignment.

Related items

Shock Absorbers
 Torque Rods & Bushings
 Height Control Valves
 Trailing Arms
 Leaf Springs
 Pivot Bushings & Hardware
 U-Bolts
 Axle Connection Pads & Bushings

Catalogs and support material

Air Spring Catalog - 209
 Shock Absorber Catalog
 Suspension Catalog - 211
 Air Spring Stock Guide
 Promotional Material
 Tech Line 800-822-2042
 Web Site - www.daytonparts.com