

Tu-Flo 501 Compressor

Service Parts Remanufactured Exchange Catalog 01-E-1

REVISED 6/83

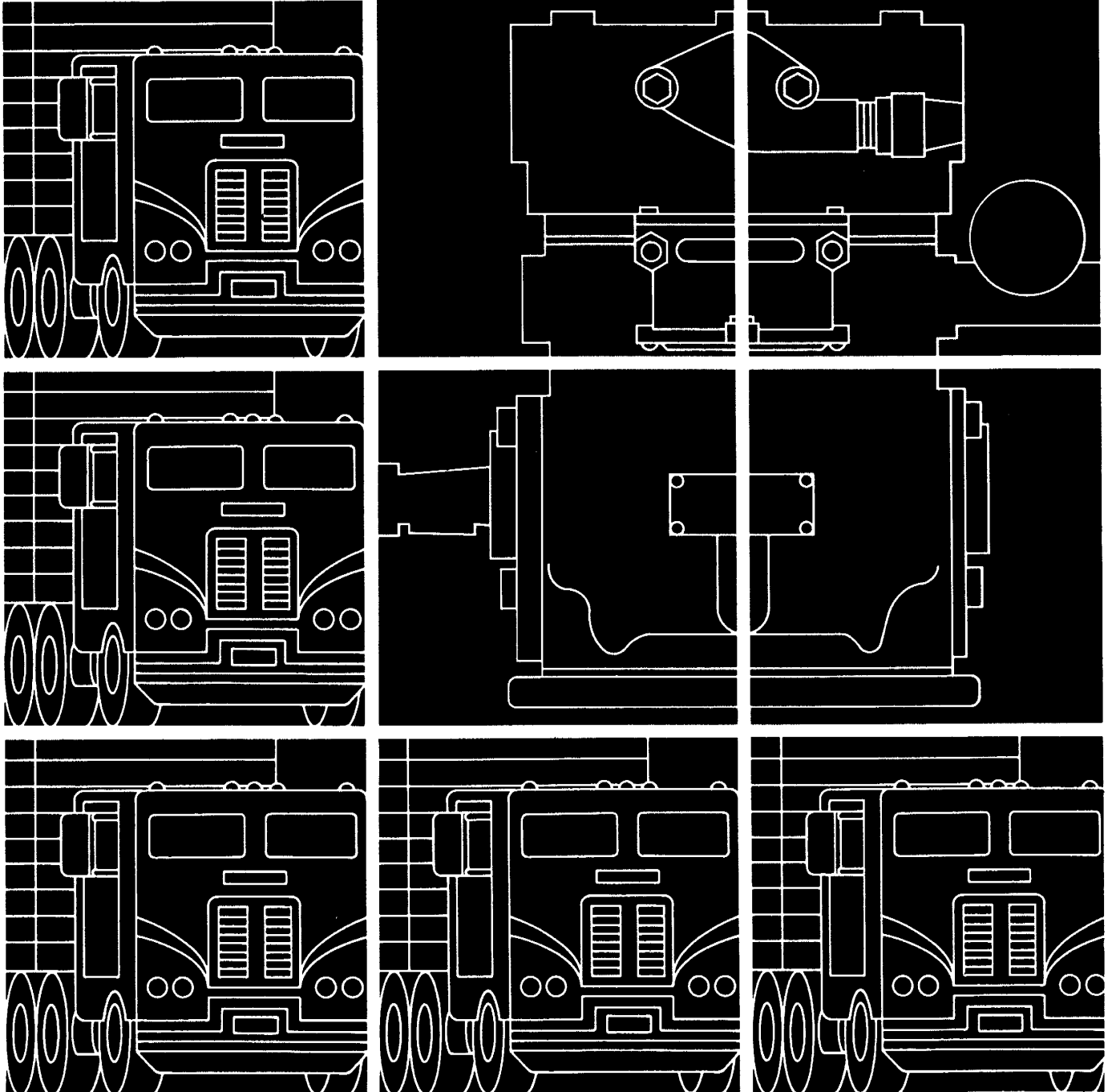

THIS CATALOG SECTION (PAGES 01-E-1 THRU 01-E-23)
SUPERSEDES CATALOG BOOKLET 01-E-1 1/79 (R 780)



The Tu-Flo 501 Compressor is an engine driven, two cylinder, reciprocating compressor with a displacement of 12 cu. ft. per min. at 1250 RPM.

It is available in an engine lubricated configuration and employs a water cooled cylinder head and air cooled block. It is available in belt drive, direct drive single flange and direct drive double flange mount configurations and features an Integral Block and Crankcase.

OPERATING LIMITATIONS: Maximum crankshaft speed - 3000 RPM
Maximum discharge temperature - 400°F.

FOR INSTALLATION AND MAINTENANCE INFORMATION SEE SERVICE DATA SD-01-3

EXCHANGE AND CHANGEOVER INFORMATION

TuFlo 501 Compressors are available with either an original equipment piece number or a remanufactured/exchange number. Common detail parts and dimensional information are illustrated in the compressor line drawings preceeding each catalog section.

Two reference schedules are listed for every O.E. piece number. One schedule displays both the O.E.M. number and the standard remanufactured exchange number, plus primary O.E. application and Bendix equivalent where applicable. O.E. piece numbers are also scheduled with configuration and accessory information.

Remanufactured/exchange compressors are illustrated by configuration and have a to/from changeover schedule with an application schedule.

NOTE: Detail Parts for Exchange Compressors (i.e. Crankcases, Crankshafts, Blocks, etc.) are not available as service parts. Exchange Compressors are not equipped with external parts or fittings.

TU-FLO 501 MAINTENANCE KIT
PC. NO. 287043 CONSISTS OF
THE FOLLOWING:

QUAN.	PC. NO.	DESCRIPTION
1	279615	MAINTENANCE KIT
1		DCHG FIT GASKET
2		DCHG VALVE
2		INLET VALVE
2		INL VLV SPRING
1		GOV GASKET
2		INLET VLV GUIDE
1		STRAINER GASKET
2		DCHG VLV SPRING
1		CYL HEAD GASKET

FIELD MAINTENANCE KITS & SERVICE PARTS LISTING

DESCRIPTION	PC. NO.	JOURNAL OR BORE SIZE
UNLOADER KIT	279615	NONE
PISTON RING SET (STD.)	286183	NONE
PISTON RING SET (.010 O.S.)	286184	NONE
PISTON RING SET (.020 O.S.)	286185	NONE
PISTON RING SET (.030 O.S.)	286186	NONE
PISTON & WRIST PIN KIT (STD.)	289113	2.626
PISTON & WRIST PIN KIT (.010 O.S.)	289114	2.636
PISTON & WRIST PIN KIT (.020 O.S.)	289115	2.646
PISTON & WRIST PIN KIT (.030 O.S.)	289116	2.656
STEEL CONN. ROD W/O INSERTS	286258	NONE
STEEL CONN. ROD W/STD. INSERTS	286259	1.126
CONN. ROD INSERT KIT (STD.) (EACH KIT CONTAINS 2 INSERTS)	286254 (M)287058	1.126
CONN. ROD INSERT KIT (.010 O.S.) (EACH KIT CONTAINS 2 INSERTS)	286255 (M)287059	1.116
CONN. ROD INSERT KIT (.020 O.S.) (EACH KIT CONTAINS 2 INSERTS)	286256 (M)287060	1.096
CONN. ROD INSERT KIT (.030 O.S.) (EACH KIT CONTAINS 2 INSERTS)	286257 (M)287061	1.086

(M) FOR MACK COMPRESSORS WITH POWER STEERING
DRIVEN BY COMPRESSOR CRANKSHAFT

NOTE: INSERT KITS ARE PACKAGED 10 PER CARTON.
ORDER IN LOTS OF 10 TO FACILITATE HANDLING

THE FOLLOWING PARTS ARE STANDARD
ON REMFR. EXCHANGE COMPRESSORS:

204820	DISCHARGE FITTING GASKET (EXCEPT WITH TOP DISCHARGE)
236577	GOV. GASKET
243430	STRAINER GASKET
230672	STUD (2) (EXCEPT WITH TOP DISCHARGE)
203145	NUT (2) (EXCEPT WITH TOP DISCHARGE)
**	FLANGE GASKET

** FLANGE GASKET IS FURNISHED WITH REMFR. EXCHANGE
COMPRESSOR. MUST BE PURCHASED SEPARATELY WITH
NEW COMPRESSOR.

THE PARTS LISTED BELOW ARE STANDARD ON TF-501 COMPRESSORS

REFER TO PAGES 5 THRU 19 FOR SPECIFIC DETAIL PARTS ON CYLINDER HEADS, CRANKCASE ASSEMBLIES, FLANGE ADAPTERS, CRANKSHAFTS, END COVERS, CRANKCASE BASE ADAPTERS, CRANKCASE COVERS, ETC.

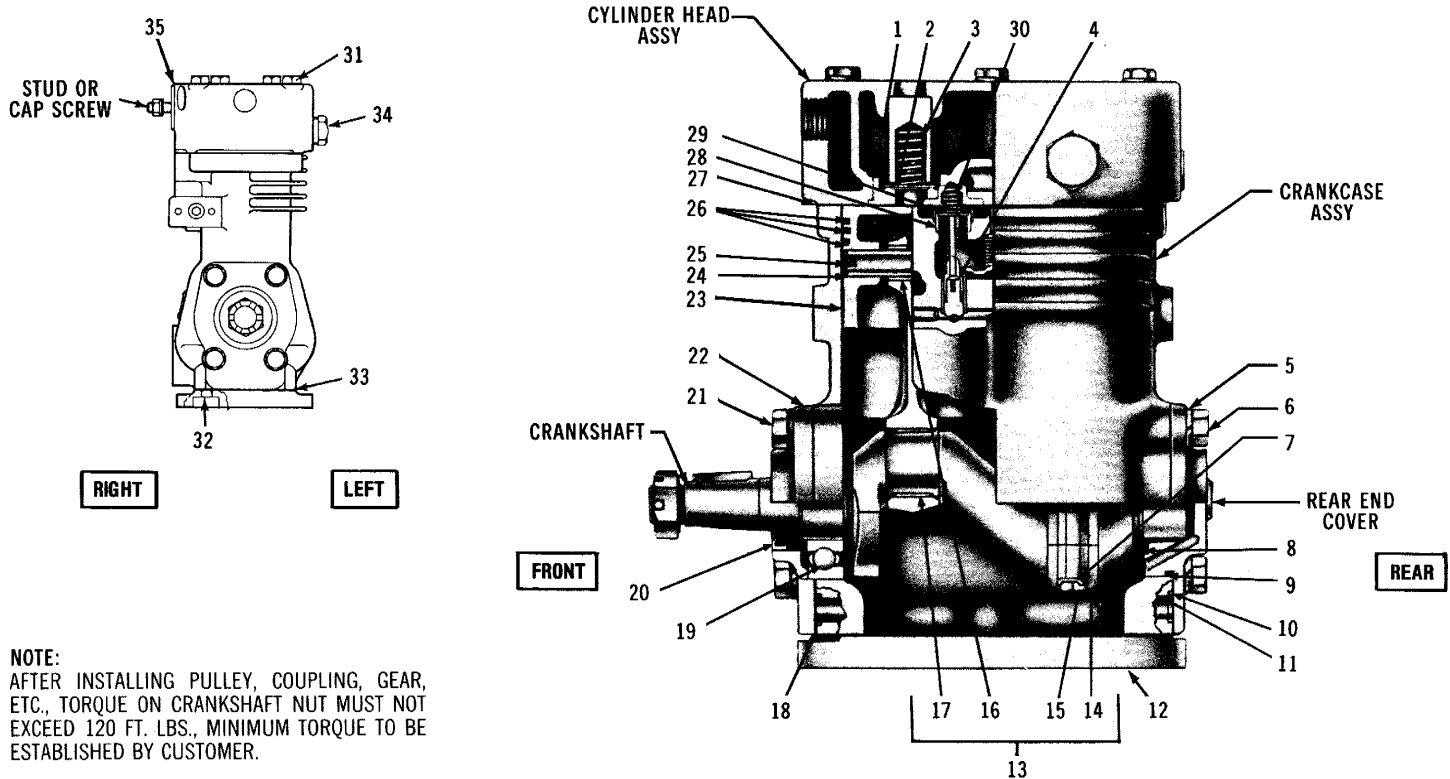

NOTE:

AFTER INSTALLING PULLEY, COUPLING, GEAR, ETC., TORQUE ON CRANKSHAFT NUT MUST NOT EXCEED 120 FT. LBS., MINIMUM TORQUE TO BE ESTABLISHED BY CUSTOMER.

NO.	PC. NO.	QUAN.	DESCRIPTION	NO.	PC. NO.	QUAN.	DESCRIPTION
	"D"	1	CYLINDER HEAD ASSY.*	18	249962	1	FRONT END COVER GASKET (IF BALL BEARING)
1	237291	2	DISCHARGE VALVE SEAT		292438	1	FRONT END COVER "O" RING (IF SLEEVE BEARING)
2	A	2	DISCHARGE VALVE	19	236120	1	BALL BEARING
3	A	2	DISCHARGE VALVE SPRING	20	243053	1	CRANKSHAFT OIL SEAL
	"D"	1	CRANKCASE ASSY.**	21	246451	4	CAP SCREW
4	B	1	UNLOADER MECHANISM	22	249961	1	FRT. END COVER
5	246441	8	LOCK WASHER	23	C	2	PISTON
6	246442	4	CAP SCREW	24	C	2	WRIST PIN
7	249959	4	LOCK STRAP	25	C	4	WRIST PIN BUTTON
	"D"		REAR END COVER	26	C	1	PISTON RING SET (STD.)
8	246439	1	THRUST WASHER		C	2	OIL RING
9	249962	1	REAR END COVER GASKET (IF BALL BEARING)		C	2	EXPANDER RING
	292438	1	REAR END COVER "O" RING (IF SLEEVE BEARING)		C	4	PISTON RING
10	293347	4	SEALING RING	27	246433	1	CYLINDER HEAD GASKET
11	293348	4	O-RING RETAINER	28	239395	2	INLET VALVE GUIDE
12	290561	1	CRANKCASE BASE ADAPTER	29	236125	2	INLET VALVE
	290559	1	OR CRANKCASE COVER	30	236126	2	INLET VALVE SPRING
13	C	2	CONNECTING ROD COMPLETE	31	246438	6	CAP SCREW
14	C	2	CONN. ROD & CAP ASSY.	32	290560	6	CAP SCREW
15	C	4	BOLT	33	294032	1	CRANKCASE COVER GASKET
16	C	2	WRIST PIN BUSHING	34	239568	2	PIPE PLUG, 1/2"
17	C	4	BEARING INSERT	35	204820	1	DISCHARGE FITTING GASKET

* ALSO INCLUDES CYL. HD. BODY. INL. VLV. SPRING INSERT. INL. VLV. SPRING SEAT & VLV. STOP

** ALSO INCLUDES CRANKCASE BODY, INLET VLV. SEAT AND BUSHING

A-FURNISHED IN MAINTENANCE KIT 287043 (PAGE 01-E-2)
 B-FURNISHED IN MAINTENANCE KIT 279615 (PAGE 01-E-2)
 C-AVAILABLE ONLY IN SETS SHOWN ON PAGE 01-E-2
 D-PC. NO. LISTED IN SUB ASSY. & DETAIL REFERENCE SECTIONS.

MAINTENANCE KITS SHOWN ON PAGE 01-E-2

VERTICAL MOUNT-THRU DRIVE-4 HOLE BASE

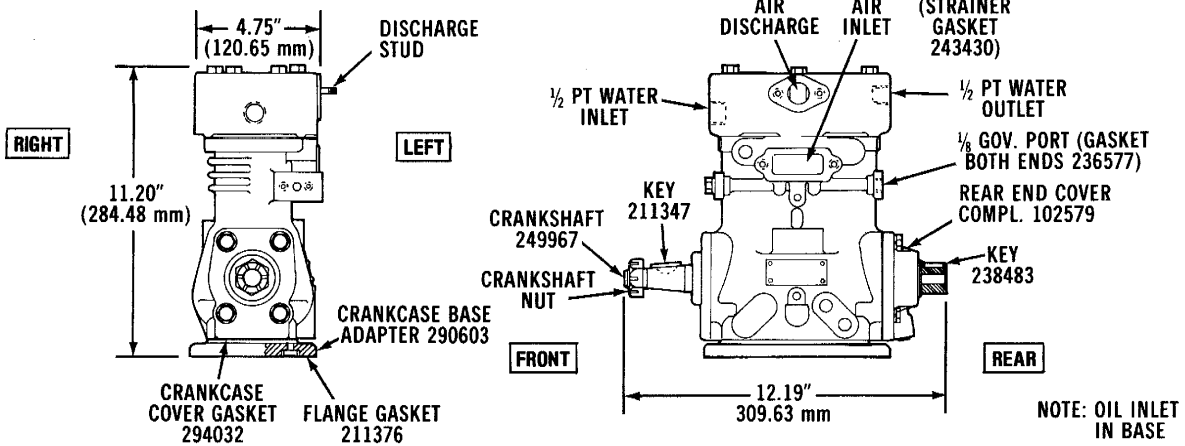

O.E. PC. NO.	REMF. EXCH. PC. NOS.	PRIMARY O.E. APPLICATION
285872	286530	D.D.A.D.
285939	286532	I.H.C.
285942	286532	D.D.A.D.
285947	286533	D.D.A.D.
286662	SAME AS 285872	EXCEPT BENDIX IDENTIFIED
286663	SAME AS 285942	EXCEPT BENDIX IDENTIFIED
286664	SAME AS 285947	EXCEPT BENDIX IDENTIFIED
288294	286533	WABCO

DETAIL REFERENCE

PC. NO.	AIR INLET LOCATION	INLET SPACER	AIR DISCHARGE LOCATION	DISCHARGE STUD	GOVERNOR LOCATION	CRANKSHAFT NUT	WATER PORTS	
							INLET	OUTLET
285872	LEFT	NONE	LEFT	NONE	LEFT REAR	245212	FRONT	REAR
285939	LEFT	NONE	TOP	NONE	LEFT REAR	245212	FRONT	REAR
285942	LEFT	NONE	TOP	NONE	LEFT REAR	245212	FRONT	REAR
285947	RIGHT	NONE	RIGHT	NONE	RIGHT REAR	202926	REAR	FRONT
288294	RIGHT	238948	RIGHT	230672	RIGHT REAR	202926	REAR	FRONT

REMG EXCH. & CHANGEVER SELECTONS

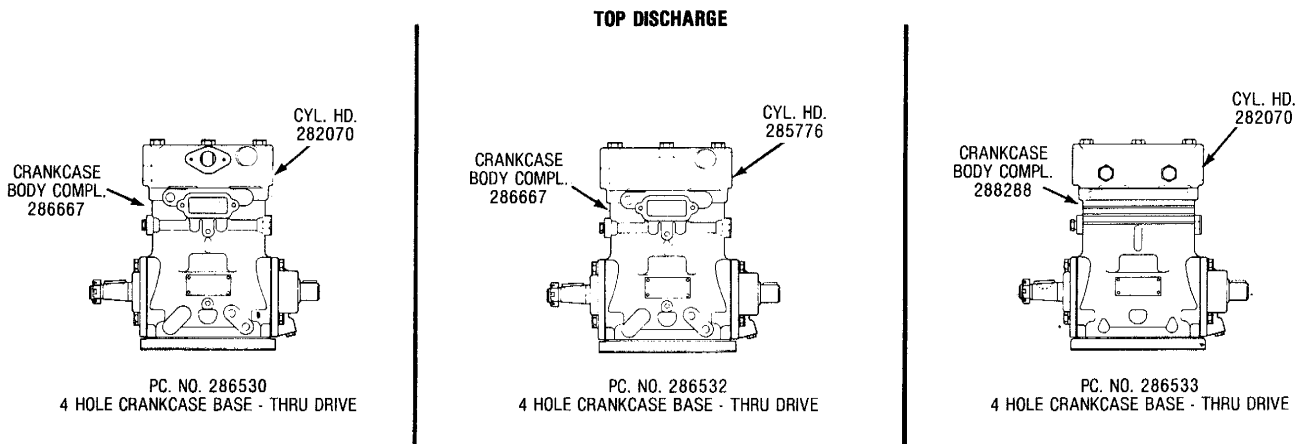

PRINTED IN U.S.A.

REMF. EXCH. PC. NOS.	CHANGEVER TO/FROM				COMPRESSOR APPLICATION	
	TU-FLO 400	TU-FLO 500	TU-FLO 600	TU-FLO 700	ENGINE	TRUCK MODEL
286530	228478	228479	281751		DD-6-71, 6-71TT, 6-71T	FORD-L, LN, LT, LNT, LTS, CL-9000
286532		279384	280784		DD-6-71, 6-71T	
286533		275990	281713		DD-6-71, 8V-92	

**VERTICAL MOUNT-4 MOUNTING HOLE CRANKCASE BASE
-6 MOUNTING HOLE CRANKCASE BASE & NO CRANKCASE BASE**

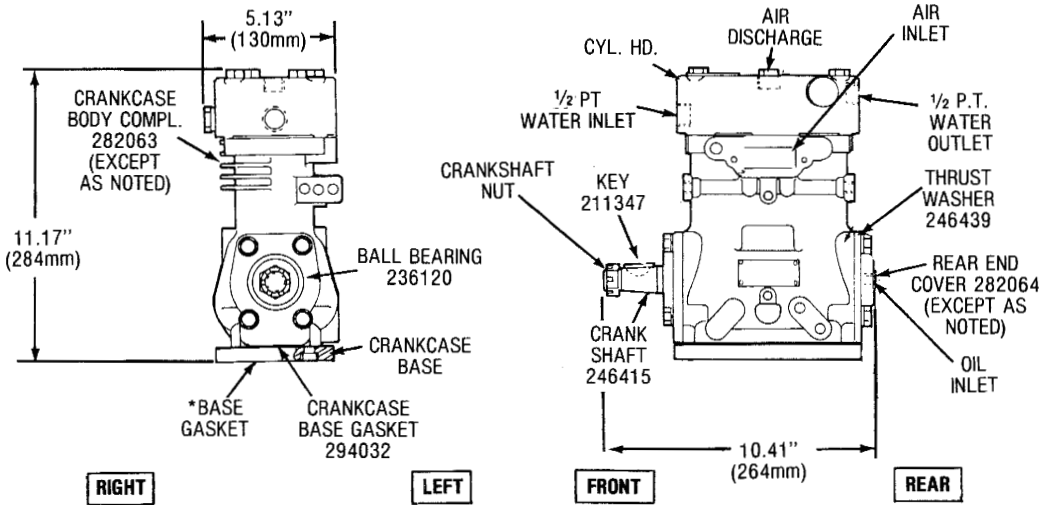

REAR END COVER PC. NO.	NOMINAL I.D.	DESCRIPTION
282064	1.381	STANDARD
285698	1.371	REPAIR
285699	1.361	REPAIR
285700	1.351	REPAIR
101706	1.341	REPAIR
286148	1.381	STANDARD
286149	1.371	REPAIR
286150	1.361	REPAIR
286151	1.351	REPAIR
101705	1.341	REPAIR

*USE 211376 WITH 290559 C. C. BASE
*USE 235907 WITH 290561 C. C. BASE

O.E. PC. NO.	REMFR. EXCH. PC. NO.	PRIMARY O.E. APPLICATION	C'CASE BASE
285861	286528	I.H.C.	4 HOLE
285862	SAME AS 285923 EXCEPT BENDIX IDENTIFIED		
285923	286576	D.D.A.D.	6 HOLE
285924	286578	D.D.A.D.	6 HOLE
285925	286536	D.D.A.D.	6 HOLE
285928	SAME AS 285924 EXCEPT BENDIX IDENTIFIED		
285929	SAME AS 285925 EXCEPT BENDIX IDENTIFIED		
285930	286526	D.D.A.D.	4 HOLE
285932	SAME AS 286692 EXCEPT BENDIX IDENTIFIED		
285937	286535	WHITE	6 HOLE
285941	286537	I.H.C.	6 HOLE
285943	286535	I.H.C.	6 HOLE
285948	286529	I.H.C.	4 HOLE
285949	286529	I.H.C.	4 HOLE
285951	286529	G.M.C.	4 HOLE
285952	286527	G.M.C.	4 HOLE
285953	286526	FORD	4 HOLE
285954	SAME AS 285953 EXCEPT BENDIX IDENTIFIED		
285955	286526	WHITE	4 HOLE
285957	286527	WHITE	4 HOLE
285959	286526	CHRYSLER	4 HOLE
285960	286560	G.M.C.	4 HOLE
285961	286527	DAYBROOK-OTTAWA	4 HOLE
285962	286527	EATON	4 HOLE
285963	286527	HANN MOTORS	4 HOLE
285964	286527	JAY MADSEN	4 HOLE
285965	286526	WAGNER MINING	4 HOLE
285966	286526	CRANE CARRIER	4 HOLE
285967	286536	I.H.C.	6 HOLE
286017	286580	CAT	NONE
286018	SAME AS 286017 EXCEPT BENDIX IDENTIFIED		
286128	286526	ALLIS-CHALMERS	4 HOLE
286131	286526	ALLIS-CHALMERS	4 HOLE
286133	286527	ALLIS-CHALMERS	4 HOLE
286134	286526	ALLIS-CHALMERS	4 HOLE
286218	286526	WHITING	4 HOLE
286514	286528	F.W.D.	4 HOLE
286641	286526	G.M.C.	4 HOLE

O.E. PC. NO.	REMFR. EXCH. PC. NO.	PRIMARY O.E. APPLICATION	C'CASE BASE
286684	SAME AS 285930 EXCEPT BENDIX IDENTIFIED		
286692	286527	D.D.A.D.	4 HOLE
286767	286527	WAUKESHA	4 HOLE
286872	286527	BLUE BIRD BODY	4 HOLE
287303	286526	OSHKOSH	4 HOLE
287483	286526	KERSHAW	4 HOLE
287629	286528	MACK	4 HOLE
287631	286567	CAT	NONE
287632	SAME AS 287631 EXCEPT BENDIX IDENTIFIED		
288060	286527	ALLIS-CHALMERS	4 HOLE
288061	286527	ALLIS-CHALMERS	4 HOLE
288062	286526	ALLIS-CHALMERS	4 HOLE
288302	286589	EATON-BATAVIA	4 HOLE
288658	286528	TAYLOR MACHINE	4 HOLE
288693	286586	WABCO	4 HOLE
288942	286582	G.M.C.	4 HOLE
288974	286526	EATON-BATAVIA	4 HOLE
289015	286591	FORD	4 HOLE
289097	286535	I.H.C. (Melrose Park)	6 HOLE
289121	286585	FORD	6 HOLE
289751	286592	CAT	NONE
101588	286595	GW OTTAWA	4 HOLE
101894	286535	DROTT-J.I. CASE	6 HOLE
101904	286591	FORD	4 HOLE
101936	SAME AS 101904 EXCEPT BENDIX IDENTIFIED		
102001	SAME AS 289015 EXCEPT BENDIX IDENTIFIED		
102002	SAME AS 289121 EXCEPT BENDIX IDENTIFIED		
102091	286591	FORD	4 HOLE
102092	SAME AS 102091 EXCEPT BENDIX IDENTIFIED		
102640	286580	CRANE CARRIER	NONE
102651	286527	FIAT-ALLIS	4 HOLE
102695	SAME AS 102688 EXCEPT BENDIX IDENTIFIED		
102688	102698	D.D.A.D.	4 HOLE
102822	286592	TOWMOTOR	NONE
102987	102989	FORD	6 HOLE
102988	SAME AS 102987 EXCEPT BENDIX IDENTIFIED		
103071	286591	FORD	4 HOLE
103072	SAME AS 103071 EXCEPT BENDIX IDENTIFIED		

VERTICAL MOUNT — 4 MOUNTING HOLE CRANKCASE BASE — 6 MOUNTING HOLE CRANKCASE BASE & NO CRANKCASE BASE
DETAIL REFERENCE

4 MOUNTING HOLE CRANKCASE BASE

PC. NO.	AIR INLET			AIR DISCHARGE		DISCHARGE STUD OR CAPScrew (2)	GOV. LOCATION	GOVERNOR	GOV. ADAPT. BRKT.	WATERPORTS		OIL INLET LOCATION	C'SHAFT NUT	C'CASE BASE
	Location	Ftg. (F) Gask (G) Strn'r (S)	INLET SPACER	Location	Gask (G) Ftg. (F) Cov. Plate (C)					Inlet	Outlet			
285861	LEFT	—	—	TOP	—	—	FRONT & REAR	—	—	FRONT	REAR	REAR	245212	290559
285930	LEFT	—	—	LEFT	—	—	LEFT REAR	—	—	FRONT	REAR	REAR	245212	290559
285948	RIGHT	—	—	TOP	—	—	RIGHT REAR	277131	—	REAR	FRONT	REAR	245212	290559
285949	RIGHT	—	—	TOP	—	—	RIGHT REAR	—	—	REAR	FRONT	REAR	245212	290559
285951	RIGHT	226469(S)	—	TOP	—	—	RIGHT REAR	276226	—	REAR	FRONT	REAR	245212	290559
285952	RIGHT	226469(S)	—	RIGHT	213042(F)	233798	RIGHT FRONT	276103	285886	REAR	FRONT	REAR	245212	290559
285953	LEFT	—	238948	LEFT	213042(F)	233798	LEFT REAR	276380	—	FRONT	REAR	REAR	245212	290559
285955	LEFT	277218(F)	238948	LEFT	213042(F)	238798	FRONT & REAR	—	—	FRONT	REAR	REAR	245212	290559
285957	RIGHT	277218(F)	238948	RIGHT	213042(F)	233798	FRONT & REAR	—	—	REAR	FRONT	RIGHT	245212	290559
285959	LEFT	279900(S)	—	LEFT	213042(F)	237315	LEFT REAR	276101	—	FRONT	REAR	REAR	245212	290559
285960	LEFT	279900(S)	—	TOP	—	—	LEFT REAR	276104	—	FRONT	REAR	REAR	202926	290559
285961	RIGHT	279900(S)	—	RIGHT	—	230672	RIGHT REAR	276336	—	REAR	FRONT	REAR	245212	290559
285962	RIGHT	—	238948	RIGHT	—	230672	RIGHT REAR	—	—	REAR	FRONT	REAR	245212	290559
285963	RIGHT	279900(S)	—	RIGHT	—	230672	RIGHT REAR	276105	—	REAR	FRONT	REAR	245212	290559
285964	RIGHT	226469(S)	—	RIGHT	—	230672	RIGHT REAR	276105	—	REAR	FRONT	REAR	245212	290559
285965	LEFT	—	—	LEFT	—	233464	LEFT REAR	—	—	FRONT	REAR	REAR	245212	290559
285966	LEFT	279900(S)	—	LEFT	—	235464	LEFT REAR	276107	—	FRONT	REAR	REAR	245212	290559
286128	LEFT	236676(F)	238948	LEFT	—	235464	LEFT FRONT	276103	—	FRONT	REAR	RIGHT	245212	290559
286131	LEFT	237461(F)	238948	LEFT	—	235464	LEFT REAR	276103	—	FRONT	REAR	REAR	245212	290559
286133	RIGHT	236676(F)	238948	RIGHT	—	235464	RIGHT REAR	236676	—	REAR	FRONT	RIGHT	245212	290559
286134	LEFT	277218(F)	238948	LEFT	—	235464	LEFT REAR	277218	—	REAR	RIGHT	REAR	245212	290559
286218	LEFT	226469(S)	—	LEFT	—	230672	LEFT REAR	226469	—	FRONT	REAR	REAR	245212	290559
286514	LEFT	279900(S)	—	TOP	—	—	LEFT REAR	279900	—	FRONT	REAR	REAR	245212	290559
286641	LEFT	229662(F)	238948	LEFT	213042(F)	237315	REAR	281137	290557	FRONT	REAR	REAR	202926	290559
286684	LEFT	—	—	LEFT	—	—	LEFT REAR	—	—	FRONT	REAR	REAR	245212	290559
286692	RIGHT	—	—	RIGHT	—	—	RIGHT REAR	—	—	REAR	FRONT	REAR	245212	290559
286767	RIGHT	240246(F)	238948	RIGHT	213042(F)	—	RIGHT REAR	276101	237189	FRONT	REAR	REAR	245212	290559
286872	RIGHT	226469(S)	—	RIGHT	245282(F)	—	RIGHT REAR	276226	—	FRONT	RIGHT	REAR	245212	290559
287303	LEFT	—	—	LEFT	—	—	LEFT REAR	—	—	FRONT	REAR	REAR	245212	290559
287483	LEFT	246691(F)	238948	LEFT	—	230992	LEFT REAR	276380	—	FRONT	REAR	REAR	245212	290559
287629	LEFT	—	238948	TOP	—	—	LEFT REAR	—	—	FRONT	REAR	REAR	245212	290559
288060	RIGHT	236676(F)	238948	RIGHT	—	233798	RIGHT REAR	276102	—	REAR	FRONT	RIGHT	245212	290559
288061	RIGHT	—	—	RIGHT	—	—	RIGHT REAR	—	—	REAR	FRONT	RT & RR	245212	290559
288062	LEFT	—	—	LEFT	—	—	LEFT REAR	—	—	FRONT	REAR	RT & RR	245212	290559
288302	RIGHT	237461(F)	238948	RIGHT	213042(F)	233798	RIGHT REAR	276105	—	REAR	FRONT	REAR	245212	290559
288658	LEFT	246691(F)	—	TOP	—	—	LEFT REAR	276101	—	FRONT	REAR	REAR	245212	290559
288693	LEFT	—	—	LEFT	—	—	LEFT REAR	—	—	FRONT	LEFT REAR	REAR	245212	290559
288942	LEFT	279900(S)	—	TOP	—	—	LEFT REAR	276104	—	FRONT	REAR	RIGHT	202926	290559
288974	LEFT	279900(S)	—	LEFT	—	235464	LEFT REAR	276380	237189	FRONT	REAR	REAR	245212	290559
289015	RIGHT	241340(F)	—	RIGHT	213042(F)	233798	RIGHT REAR	276336	—	REAR	FRONT	REAR	245212	292774
101588	RIGHT	241340	238948	TOP	—	—	RIGHT REAR	276108	—	REAR	FRONT	REAR	245212	292774
101904	RIGHT	241340	238948	RIGHT	213042	237315	RIGHT REAR	102030	—	REAR	FRONT	RIGHT	245212	292774
102091	RIGHT	241340	238948	RIGHT	239123	237757	RIGHT REAR	102030	—	REAR	FRONT	RIGHT	245212	292774
102651	RIGHT	277218	238948	RIGHT	213042	237315	RIGHT REAR	276103	—	FRONT	REAR	RIGHT	245212	290559
102688	LEFT	—	—	LEFT	—	—	LEFT REAR	—	—	FRONT	REAR	REAR	245212	290559
103071	RIGHT	241340(F)	238948	RIGHT	239123(F)	230672	RIGHT REAR	103769	—	REAR	FRONT	REAR	245212	292774

6 MOUNTING HOLE CRANKCASE BASE

285923	RIGHT	—	—	RIGHT	—	—	RIGHT REAR	—	—	REAR	FRONT	REAR	245212	290561
285924	LEFT	—	—	LEFT	—	—	LEFT REAR	—	—	FRONT	REAR	REAR	245212	290561
285925	RIGHT	—	—	TOP	—	—	RIGHT REAR	—	—	REAR	FRONT	REAR	245212	290561
285937	RIGHT	—	—	RIGHT	—	—	FRONT & REAR	—	—	REAR	FRONT	REAR	245212	290561
285941	LEFT	—	—	TOP	—	—	LEFT FRONT	—	—	FRONT	REAR	REAR	245212	290561
285943	RIGHT	—	—	RIGHT	—	—	RIGHT FRONT	—	—	REAR	FRONT	REAR	245212	290561
285967	RIGHT	246691(F)	238948	TOP	—	—	RIGHT REAR	—	—	REAR	FRONT	REAR	245212	290561
289097	RIGHT	246691(F)	238948	RIGHT	—	—	RIGHT REAR	—	—	REAR	FRONT	REAR	245212	290561
289121	LEFT	—	—	LEFT	213042(F)	233798	LEFT REAR	102033	—	FRONT	REAR	REAR	245212	292441
101894	RIGHT	279900(S)	—	RIGHT	213042(F)	237315	FRONT & REAR	—	—	REAR	FRONT	REAR	245212	290561
102987	RIGHT	241340	238948	RIGHT	239123(F)	237757	RIGHT REAR	103770	—	REAR	FRONT	REAR	245212	292441

NO CRANKCASE BASE

286017	LEFT	—	238948	LEFT	237438(F)	230992	LEFT REAR	—	—	FRONT	REAR	REAR	202926	—
287631	RIGHT	241340(F)	—	TOP	—	—	RIGHT REAR	—	—	LEFT	REAR	REAR	202926	—
289751	RIGHT	241340(F)	—	RIGHT	237438(F)	230992	RIGHT FRONT	—	—	REAR	FRONT	REAR	202926	—
102640	LEFT	279900(S)	—	LEFT	237438(F)	230992	LEFT REAR	—	—	FRONT	REAR	REAR	245212	—
102822	RIGHT	241340(F)	—	RIGHT	237438(F)	230992	RIGHT REAR	—	—	REAR	FRONT	REAR	245212	—

NOTE: MINOR PIPING MODIFICATIONS MAY BE NECESSARY

VERTICAL REMFR. EXCH. COMPRESSORS
REMFR. EXCH. & CHANGEOVER SELECTIONS

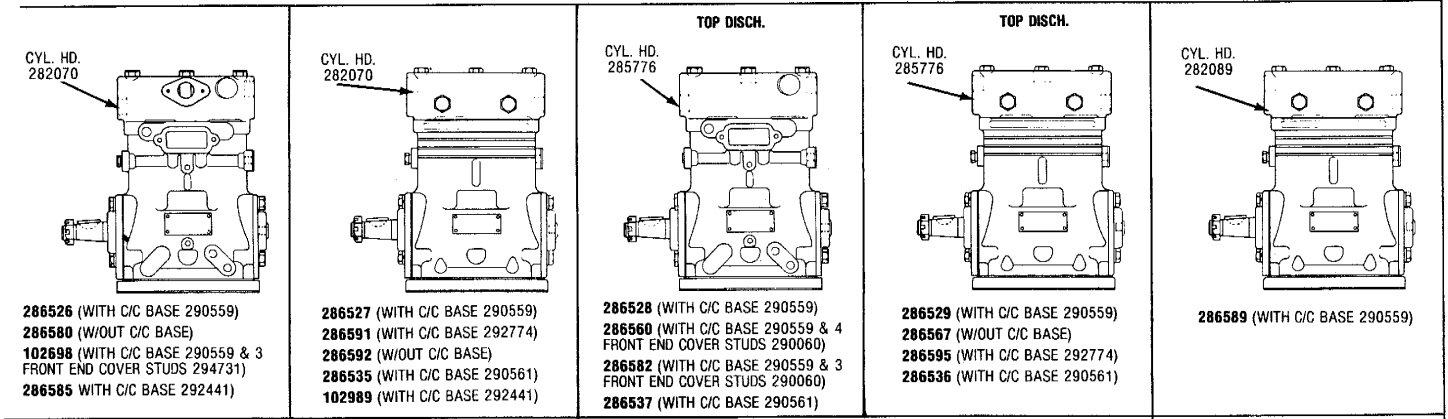

REMFR. EXCH. PC. NOS.	CHANGEOVER TO/FROM				COMPRESSOR APPLICATION	
	TU-FLO 400	TU-FLO 500	TU-FLO 600	TU-FLO 700	ENGINE	TRUCK MODEL
286526	227404	227320	280613	289350	CAT-3208	FORD, LT, LTS-8000, LN-9000
286527	227403	227322	280603	101256	IHC-V-345/392, MV8-404/446, VS-537/606, D150-170-190	INTERNATIONAL HARVESTER IHC S-SERIES
286528	—	228140	280540	289350	CAT-3208	IHC TRANSTAR
286529	—	227321	280551	101256	—	—
286560	—	—	—	—	—	—
286582	—	—	—	—	—	—
286586	—	—	—	—	—	—
286589	—	—	—	103051	—	—
286591	289688	—	—	—	FORD	FORD C, CT, L, LT, LTS, LN LNT 800
286595	—	—	—	—	—	—
102698	—	—	—	—	—	—

6 MOUNTING HOLE CRANKCASE BASE

286535	289610 227408	—	282274	289924	—	—
286536	—	283644	—	—	DETROIT DIESEL 6V-53	—
286576	—	—	—	—	DETROIT DIESEL (VARIOUS)	—
286537	—	—	—	—	—	—
286578	—	—	—	—	DETROIT DIESEL (VARIOUS)	—
286585	101142	—	—	102598	CAT-3208	FORD LT, LTS-8000, LN-9000
102989	103074	—	—	—	CAT-3208	FORD LT, LTS-8000, LN-9000

NO CRANKCASE BASE

286567	—	—	—	—	—	—
286580	—	—	—	—	CAT-3208	CATERPILLAR TRACTOR
286592	—	—	—	—	—	—

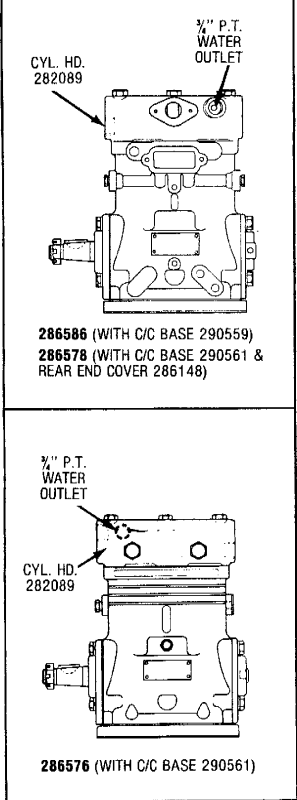

CRANKCASE BASES

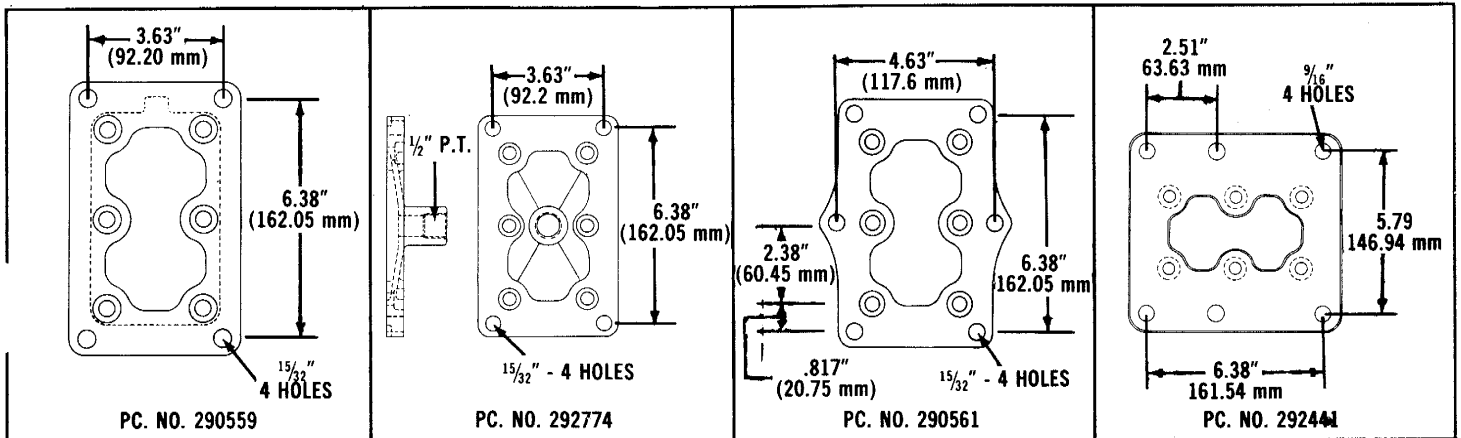

TU-FLO 501 COMPRESSOR

FORD SIDE MOUNT

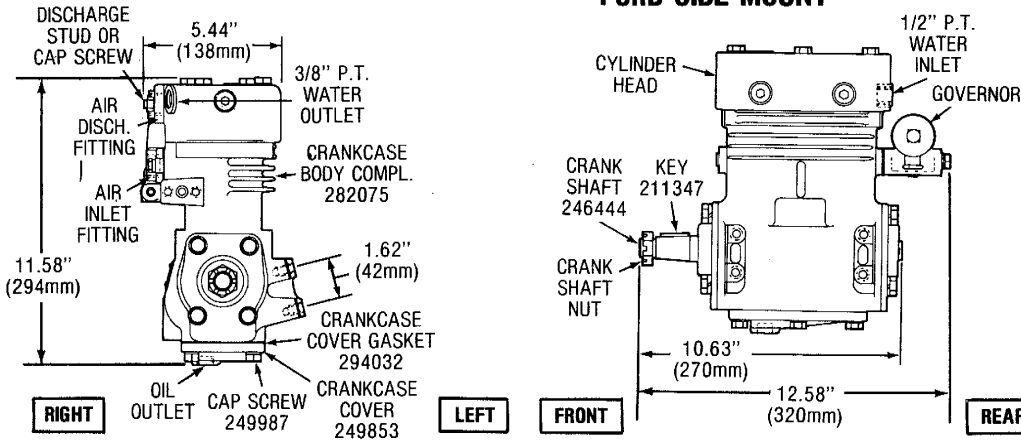

REAR END COVER PC. NO.	NOMINAL I.D.	DESCRIPTION
282064	1.381	STANDARD
285698	1.371	REPAIR
285699	1.361	REPAIR
285700	1.351	REPAIR
101706	1.341	REPAIR

O.E. PC. NO.	REMFR. EXCH. PC. NO.	PRIMARY O.E. APPLICATION
285868	SAME AS 286008 EXCEPT BENDIX IDENTIFIED	
286008	286556	FORD
286009	286565	FORD
286010	SAME AS 286009 EXCEPT BENDIX IDENTIFIED	
286011	286556	FORD
286012	SAME AS 286011 EXCEPT BENDIX IDENTIFIED	
286014	286557	R & O PRODUCTS
287034	286564	DODGE
288087	286565	FORD
288088	SAME AS 288087 EXCEPT BENDIX IDENTIFIED	
102726	102734	FORD

DETAIL REFERENCE

O.E. PC. NO.	AIR INLET		INLET SPACER	AIR OUTLET		DISCHARGE STUD OR CAP SCREW	GOVERNOR	GOVERNOR LOCATION	WATER PORTS		C'SHAFT NUT	OIL INC. LOCATION
	LOCATION	AIR STRN'R(S) OR FITTING (F)		LOCATION	DISCH FIG				INLET	OUTLET		
286008	RIGHT	241340(F)	238948	RIGHT	213042	233798	276336	RIGHT REAR	REAR	RT FRONT	245212	RIGHT
286009	RIGHT	241340(F)	238948	RIGHT	213042	233798	276336	RIGHT REAR	REAR	FRONT	245212	REAR
286011	RIGHT	226469(S)	—	RIGHT	—	233798	276336	RIGHT REAR	REAR	FRONT	245212	RIGHT
286014	RIGHT	226469(S)	—	TOP	—	—	276336	RIGHT REAR	REAR	FRONT	245212	RIGHT
287034	LEFT	279900(S)	—	LEFT	213042	237315	276101	LEFT REAR	FRONT	REAR	—	REAR
288087	RIGHT	241340(F)	238948	RIGHT	213042	233798	—	RIGHT REAR	REAR	FRONT	245212	REAR
102726	LEFT	226469(S)	—	LEFT	—	233798	276101	LEFT REAR	FRONT	REAR	202926	REAR

REMANUFACTURED EXCH. AND CHANGEVER SELECTIONS

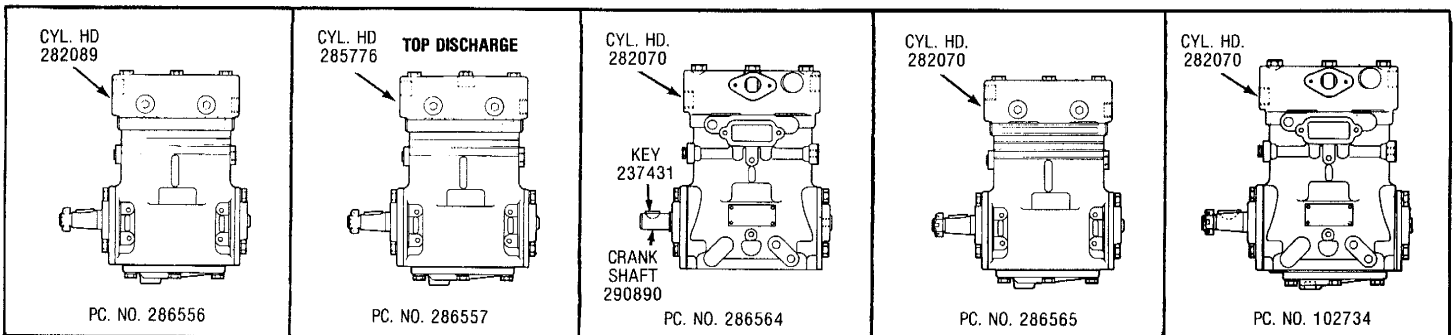

REMFR. EXCH. PC. NO.	TU-FLO 400	CHANGEVER TO/FROM			COMPRESSOR APPLICATION	
		TU-FLO 500	TU-FLO 600	TU-FLO 700	ENGINE	TRUCK MODEL
286556	—	—	—	—	—	—
286557	—	285601	—	—	—	—
286564	289545	—	—	—	—	—
286565	289821	228366	283662	—	CAT 3406	FORD C-7000 & 8000
102734	—	279252	280446	—	—	—

FORD OFFSET MOUNT

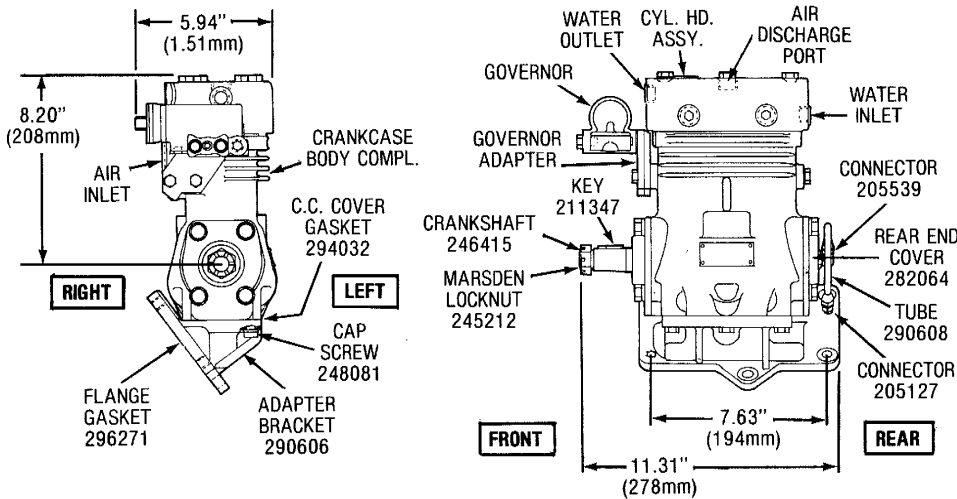

REAR END COVER PC. NO.	NOMINAL I.D.	DESCRIPTION
282064	1.381	STANDARD
285698	1.371	REPAIR
285699	1.361	REPAIR
285700	1.351	REPAIR
101706	1.341	REPAIR

	O.E. PC. NO.	REMFR. EXCH. PC. NO.	PRIMARY O.E. APPLICATION
A	285876	SAME AS 285927 EXCEPT BENDIX IDENTIFIED	
	285927	286558	FORD
	286006	286561	FORD
B	286007	SAME AS 286006 EXCEPT BENDIX IDENTIFIED	
	286884	286562	FORD
B	286885	SAME AS 286884 EXCEPT BENDIX IDENTIFIED	

A - USE GOVERNOR 276108
 B - USE GOVERNOR 276380

DETAIL REFERENCE

NOTE: MINOR PIPING MODIFICATIONS MAY BE NECESSARY

O.E. PC. NO.	AIR INLET LOCATION	INLET SPACER	AIR DISCH. LOCATION	GOVERNOR PC. NO.	GOVERNOR PORT LOCATION	WATER PORTS		OIL INLET LOCATION	GOVERNOR ADAPTER
						INLET	OUTLET		
285927	RIGHT	238948	TOP	102030	FRONT	REAR	FRONT	BASE	287339
286006	LEFT	—	TOP	102032	LEFT REAR	FRONT	REAR	BASE	—
286884	LEFT	—	TOP	102032	LEFT REAR	FRONT	LEFT REAR	BASE	290816

REMANUFACTURED EXCH. AND CHANGEOVER SELECTIONS

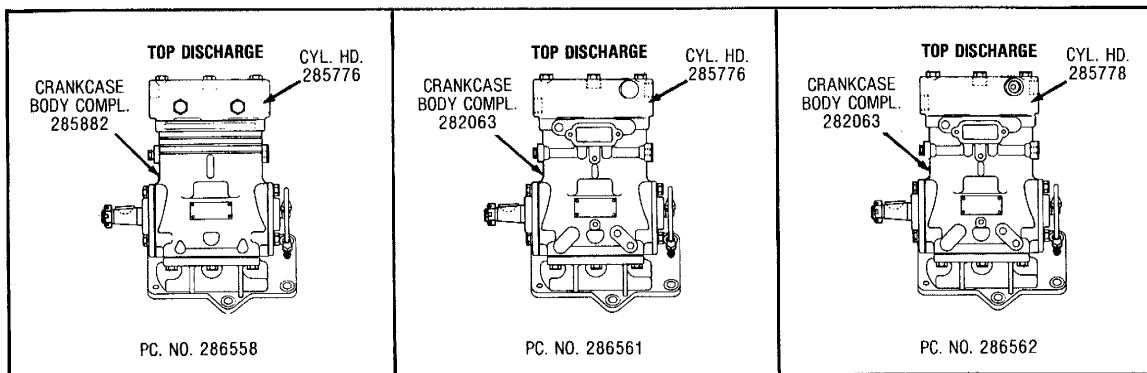

REMFR. EXCH. PC. NOS.	CHANGEOVER TO/FROM				COMPRESSOR APPLICATION	
	TU-FLO 400	TU-FLO 500	TU-FLO 600	TU-FLO 700	ENGINE	TRUCK MODEL
286558	*101247	*283513	—	—	FORD SUPER DUTY (GAS)	L, LN, LT-900
286561	*101246	*229078	*280624	—	FORD SUPER DUTY (GAS)	C-900, CT-900
286562	—	—	—	—	—	—

*NOT A DIRECT CHANGEOVER — FOR REFERENCE ONLY — BASE MOUNTING DIMENSIONS ARE DIFFERENT.

TU-FLO 501 COMPRESSOR

MACK/CATERPILLAR/VOLVO FLANGE MOUNTS

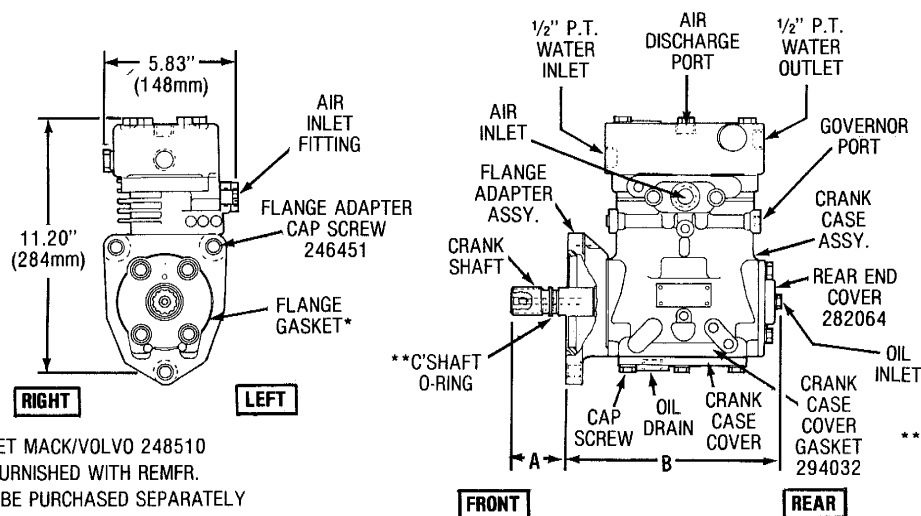

REAR END COVER PC. NO.	NOMINAL I.D.	DESCRIPTION
282064	1.381	STANDARD
285698	1.371	REPAIR
285699	1.361	REPAIR
285700	1.351	REPAIR
101706	1.341	REPAIR

*FLANGE GASKET MACK/VOLVO 248510
CAT 296627 FURNISHED WITH REMFR.
COMPR. MUST BE PURCHASED SEPARATELY
WITH NEW COMPR.

**C*SHAFT O-RING 296272 SUPPLIED WITH
REMFR'D. CAT COMPR. AS NOTED. MUST
BE PURCHASED SEPARATELY WITH NEW
COMPR.

O.E. NO.	REMFR. EXCH. PC. NO.	PRIMARY O.E. APPLICATION
285878	SAME AS 286029 & 287605 EXCEPT BENDIX IDENT.	
286019	286547	CATERPILLAR
286020	SAME AS 286019 EXCEPT BENDIX IDENT.	
286021	286548	CATERPILLAR
286022	SAME AS 286021 EXCEPT BENDIX IDENT.	
286023	286549	CATERPILLAR
286024	SAME AS 286023 EXCEPT BENDIX IDENT.	
286025	286550	CATERPILLAR
286026	SAME AS 286025 EXCEPT BENDIX IDENT.	
286027	286551	CATERPILLAR
286028	SAME AS 286027 EXCEPT BENDIX IDENT.	
**286029	286546	CATERPILLAR
286030	286552	CATERPILLAR
286031	SAME AS 286030 EXCEPT BENDIX IDENT.	
286104	286563	VOLVO-SCANIA
286105	286572	MACK

O.E. NO.	REMFR. PC. NO.	PRIMARY APPLICATION
286106	286571	MACK
**287605	286546	WHITE
287609	286566	CATERPILLAR
287610	SAME AS 287609 EXCEPT BENDIX IDENT.	
**288906	286546	I.H.C.
**288951	286546	I.H.C.
289261	286593	CATERPILLAR
**101608	286546	CATERPILLAR
288982	286544	MACK
102658	102697	MACK
102696	SAME AS 102658 EXCEPT BENDIX IDENT.	
102769	102785	VOLVO-SCANIA
102991	286563	VOLVO-SCANIA
103167	103274	CATERPILLAR
103273	SAME AS 103167 EXCEPT BENDIX IDENT.	

DETAIL REFERENCE

O.E. PC. NO.	AIR INLET LOCATION	AIR STRN'R OR FITTING	INLET SPACER	AIR OUTLET		STUD OR CAPSCREW	CRANKSHAFT AND STYLE	WATER PORTS		CRANKCASE COVER	A DIMM	B DIMM	FLANGE ADAPTER
				LOCATION	DISCH FTG			INLET	OUTLET				
286019	RIGHT	241340	238948	RIGHT	237438	230992	290074-1 1/2" TAPER PER FT.	REAR	FRONT	246460	2.59	9.13	246463
286021	LEFT	241340	238948	LEFT	237438	230992	249979-SPLINED	FRONT	REAR	290075	2.45	9.30	246463
**286023	RIGHT	241340	238948	RIGHT	237438	230992	249979-SPLINED	REAR	FRONT	246460	2.45	9.41	246463
286025	LEFT	—	—	LEFT	—	—	290071-1 1/2" TAPER PER FT.	FRONT	REAR	246460	1.50	9.02	246463
286027	RIGHT	—	—	TOP	—	—	290071-1 1/2" TAPER PER FT.	REAR	FRONT	246460	1.50	9.13	246463
286029	LEFT	241340	238948	TOP	—	—	290225-SPLINED	FRONT	REAR	249980	2.45	9.30	246463
286030	LEFT	—	—	TOP	—	—	290071-1 1/2" TAPER PER FT.	RIGHT	LEFT	—	1.50	9.41	246463
286104	RIGHT	—	—	RIGHT	—	—	290099-STRAIGHT	FRONT	REAR	286113	1.71	8.96	246463
286105	LEFT	—	—	TOP	—	—	290099-STRAIGHT	REAR	FRONT	246460	1.72	8.96	290097
286106	LEFT	—	—	TOP	—	—	290100-1 1/2" TAPER PER FT.	REAR	FRONT	246460	4.56	8.96	290097
287605	LEFT	241340	238948	TOP	—	—	290225-SPLINED	FRONT	REAR	249980	2.45	9.30	246463
287609	RIGHT	—	—	TOP	—	—	290071-1 1/2" TAPER PER FT.	REAR	FRONT	249980	1.71	8.96	246463
288906	LEFT	—	—	TOP	—	—	290225-SPLINED	FRONT	REAR	249980	2.45	9.30	246463
288951	LEFT	241340	238948	TOP	—	—	290225-SPLINED	FRONT	REAR	249980	2.45	9.30	246463
289261	RIGHT	—	—	TOP	—	—	290071-1 1/2" TAPER PER FT.	REAR	FRONT	—	1.50	9.13	246463
101608	LEFT	241340	—	TOP	—	—	290225-SPLINED	FRONT	REAR	249980	2.45	9.02	24646
288982	RIGHT	—	—	RIGHT	—	—	290033-STRAIGHT	REAR	FRONT	246460	NA	11.24	29232
102658	RIGHT	—	—	TOP	—	—	290033-STRAIGHT	REAR	FRONT	246460	NA	11.30	292321
102769	LEFT	—	—	LEFT	—	—	290099-STRAIGHT	FRONT	REAR	286113	1.71	8.96	290097
****102991	RIGHT	—	—	RIGHT	—	—	290099-STRAIGHT	FRONT	REAR	286113	1.71	8.96	290098
103167	LEFT	241340	—	TOP	—	—	296352-1 1/2" TAPER PER FT.	FRONT	REAR	246460	1.98	8.27	296137

***USE GOVERNOR 276336
****USE GOVERNOR 286436

**MACK/CATERPILLAR/VOLVO FLANGE MOUNTS
REMFR. EXCH. & CHANGEOVER SELECTIONS**

<p>PC. NO. 286544</p>	<p>PC. NO. 286546</p>	<p>PC. NO. 286547</p>	<p>PC. NO. 286548</p>	<p>PC. NO. 286549</p>
<p>PC. NO. 286550</p>	<p>PC. NO. 286551</p>	<p>PC. NO. 286552 * PC. NO. 103274 2°-30° TILT</p>	<p>PC. NO. 286563</p>	<p>PC. NO. 286566</p>
<p>PC. NO. 286571</p>	<p>PC. NO. 286572</p>	<p>PC. NO. 286593</p>	<p>PC. NO. 102697</p>	<p>PC. NO. 102785</p>

* NOTE: SAME AS 286552 EXCEPT FLANGE 296137 2° 30' TILT & THREADED MOUNTING HOLE

REMFR. EXCH. PC. NOS.	CHANGEOVER TO/FROM				COMPRESSOR APPLICATION	
	TU-FLO 400	TU-FLO 500	TU-FLO 600	TU-FLO 700	ENGINE	TRUCK MODEL
286544	—	284662	285108 **	289340**	MACK 6 CYLINDER	—
286546	—	285131	288710	289349	CAT 3406	VARIOUS
286547	—	283996	—	—	—	—
286548	—	284003	—	—	—	—
286549	—	277730	—	—	—	—
286550	—	279995	284022	—	—	—
286551	—	284310	288481	—	CAT 1693	VARIOUS
286552	—	284260	289172	289744	CAT V-8 & 3408 3412	VARIOUS
286563	280728	280737	287828	289347	—	—
286566	—	—	—	—	6.25-6 D94	CAT CRAWLER TRACTORS
286571	—	284711	286871	—	—	—
286572	—	—	286866	289347	—	—
286593	—	—	—	—	CAT 3412	CAT TRACTOR INDUSTRIAL ENGINES
102697	—	—	—	289340	—	—
102785	—	—	—	102089	—	—
103274	—	—	—	103278	CAT 3408	VARIOUS

** WHEN CHANGING OVER FROM A TU-FLO 501 TO A TU-FLO 500, 600 OR 700 POWER STEERING PUMP DRIVE HOUSING (MACK PART NO. 756GB217) AND POWER STEERING PUMP COUPLING HUB (MACK PART NO. 792GB17) MUST BE OBTAINED THROUGH MACK PARTS OUTLETS. REFER TO MACK SERVICE BULLETIN NO. R47 DATED 11-19-76

**FLANGE GASKET IS 245370
FURNISHED WITH REMFR. EXCH. COMPR.
MUST BE PURCHASED SEPARATELY
WITH NEW COMPR.

MISCELLANEOUS FLANGE MOUNTS

Mack "Foxhead" Flange

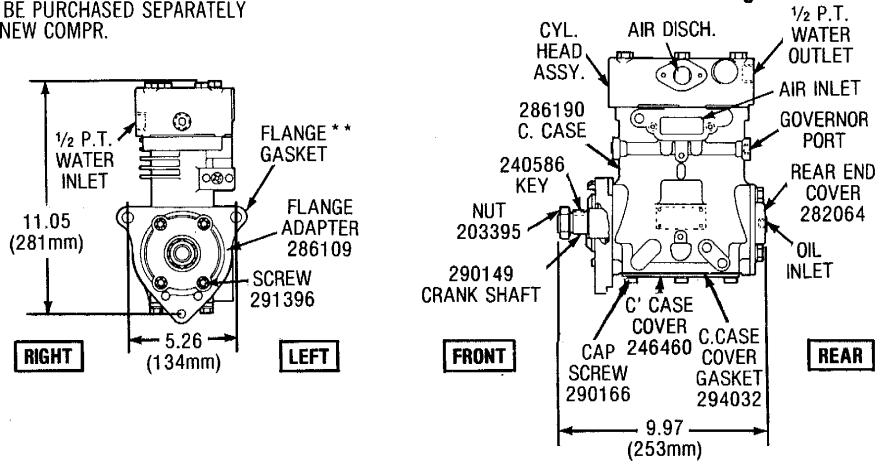

END COVER PC. NO.	NOMINAL I.D.	DESCRIPTION
282064	1.381	STANDARD
285698	1.371	REPAIR
285699	1.361	REPAIR
285700	1.351	REPAIR
101706	1.341	REPAIR

O.E. PC. NO.	REMFR. EXCH. PC. NO.	PRIMARY O.E. APPLICATION
286145	286574	MACK
102870	102953	MACK
102954	SAME AS 102870 EXCEPT BENDIX IDENT.	

DETAIL REFERENCE

O.E. PC. NO.	CYL. HD. ASSEMBLY	AIR INLET LOCATION	AIR DISCH. LOCATION	GOVERNOR LOCATION	WATER PORTS	
					INLET	OUTLET
286145	282070	LEFT	LEFT	LEFT REAR	RT. FRT.	REAR
102870	285776	LEFT	TOP	LEFT REAR	REAR	RT. FRONT

REMFR. EXCH. & CHANGEVER SELECTIONS

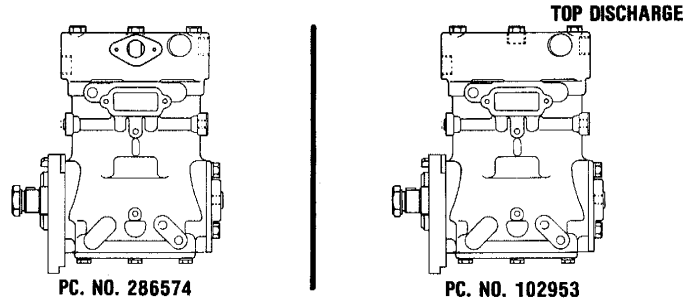

REMFR. EXCH. PC. NOS.	CHANGEVER TO/FROM				COMPRESSOR APPLICATION	
	TU-FLO 400	TU-FLO 500	TU-FLO 600	TU-FLO 700	ENGINE	TRUCK MODEL
286574	—	277122	280628	289348	ALL TRUCK/TRACTOR MODELS AND ENGINE COMBINATIONS USING THE MACK 8 CYLINDER	
102953	—	—	—	289348		

CATERPILLAR FLANGE MOUNT

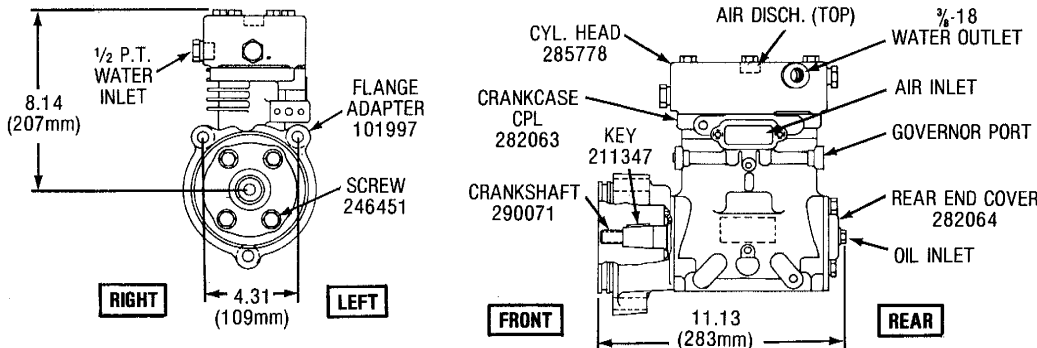

END COVER PC. NO.	NOMINAL I.D.	DESCRIPTION
282064	1.381	STANDARD
285698	1.371	REPAIR
285699	1.361	REPAIR
285700	1.351	REPAIR
101706	1.341	REPAIR

O.E. PC. NO.	REMFR. EXCH. PC. NO.	PRIMARY O.E. APPLICATION
102077	286596	CATERPILLAR
102078	SAME AS 102077 EXCEPT BENDIX IDENT.	

REMFR. EXCH. & CHANGEVER SELECTIONS

REMFR. EXCH. PC. NOS.	CHANGEVER TO/FROM				COMPRESSOR APPLICATION	
	TU-FLO 400	TU-FLO 500	TU-FLO 600	TU-FLO 700	ENGINE	TRUCK MODEL
286596	—	—	—	101884	CATCO 3408	—

**MISCELLANEOUS FLANGE MOUNTS
CATERPILLAR FLANGE MOUNT**

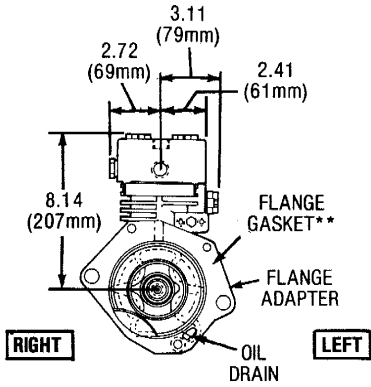

**FLANGE GASKET IS 291954
FURNISHED WITH REMFR. EXCH. COMPR.
MUST BE PURCHASED SEPARATELY WITH NEW COMPR.

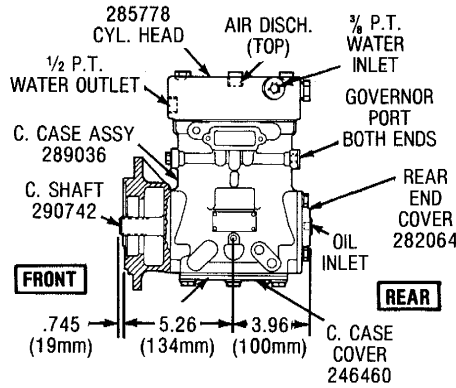

END COVER PC. NO.	NOMINAL I.D.	DESCRIPTION
282064	1.381	STANDARD
285698	1.371	REPAIR
285699	1.361	REPAIR
285700	1.351	REPAIR
101706	1.341	REPAIR

O.E. PC. NO.	REMAN EXCH PC. NO.	PRIMARY O.E. APPLICATION
288071	SAME AS 289043 EXCEPT BENDIX IDENT.	
289043	286584	CAT
101519	286584	CAT
102656	286584	CAT
102691	SAME AS 102656 EXCEPT BENDIX IDENT.	
102797	SAME AS 101519 EXCEPT BENDIX IDENT.	

DETAIL REFERENCE

O.E. PC. NO.	AIR INLET		INLET SPACER	AIR DISCH	FLANGE ADAPTER ASSY
	LOCATION	FITTING			
289043	LEFT	241340	—	TOP	289056
101519	LEFT	241340	238948	TOP	101520
102656	LEFT	294726	238948	TOP	101520

REMFR. EXCH. & CHANGEVER SELECTIONS

REMFR. EXCH. PC. NO.	CHANGEVER TO/FROM				COMPRESSOR APPLICATION	
	TU-FLO 400	TU-FLO 500	TU-FLO 600	TU-FLO 700	ENGINE	TRUCK MODEL
286584	289541	284790	—	289336	CAT. 3306	CATERPILLAR (OFF-HIGHWAY)

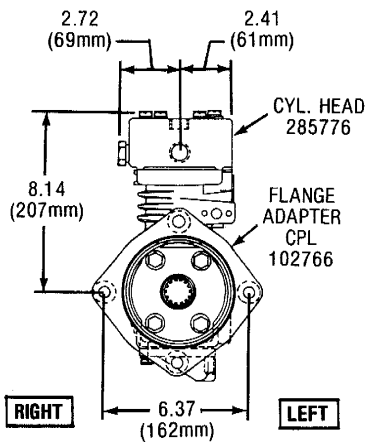

CATERPILLAR FLANGE MOUNT

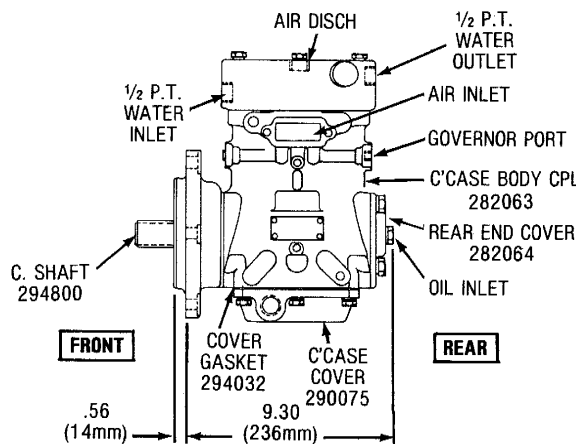

END COVER PC. NO.	NOMINAL I.D.	DESCRIPTION
282064	1.381	STANDARD
285698	1.371	REPAIR
285699	1.361	REPAIR
285700	1.351	REPAIR
101706	1.341	REPAIR

O.E. PC. NO.	REMAN EXCH PC. NO.	PRIMARY O.E. APPLICATION
102764	102742	CAT
102743	SAME AS 102764 EXCEPT BENDIX IDENT.	

DETAIL REFERENCE

O.E. PC. NO.	AIR INLET LOCATION	AIR INLET FITTING	AIR DISCH LOCATION	GOVERNOR PORT LOCATION
102764	LEFT	241340	TOP	LEFT REAR

REMFR. EXCH. & CHANGEVER SELECTIONS

REMFR. EXCH. PC. NO.	CHANGEVER TO/FROM				COMPRESSOR APPLICATION	
	TU-FLO 400	TU-FLO 500	TU-FLO 600	TU-FLO 700	ENGINE	TRUCK MODEL
102742	—	—	—	—	CAT 3512	777B

CUMMINS FLANGE MOUNT

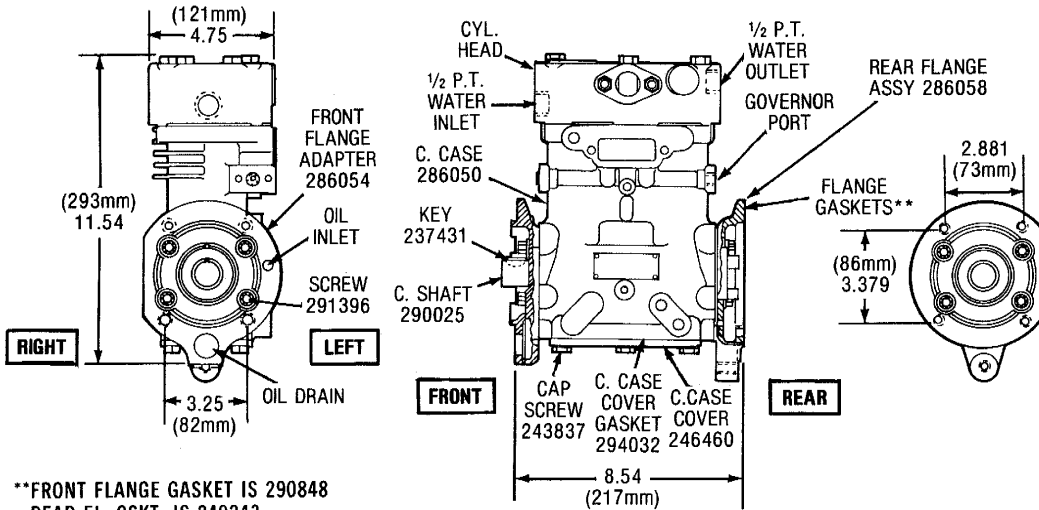

**FRONT FLANGE GASKET IS 290848
 REAR FL. GSKT. IS 249243
 FURNISHED WITH REMFR. EXCH. COMPR.
 MUST BE PURCHASED SEPARATELY
 WITH NEW COMPR.

REAR FLANGE PC. NO.	CRANKSHAFT BEARING	NOMINAL I.D.	REMARK
286058	290020	2.0045	STANDARD
		2.0025	
286059	290021	1.9945	REPAIR
		1.9925	
286060	290022	1.9845	REPAIR
		1.9825	
286061	290023	1.9745	REPAIR
		1.9725	

FRONT FLANGE PC. NO.	CRANKSHAFT BEARING	NOMINAL I.D.	REMARKS
286054	246430	1.382-1.380	STANDARD
286055	249808	1.372-1.370	REPAIR
286056	249809	1.362-1.360	REPAIR
286057	249810	1.352-1.350	REPAIR
101715	293040	1.342-1.340	REPAIR

O.E. PC. NO.	REMFR EXCH PC. NO.	PRIMARY O.E. APPLICATION
*286037	286554	CUMMINS
286040	286555	I.H.C.
286042	286555	I.H.C.
286103	286554	I.H.C.
286970	286554	WHITE
101556	286554	CUMMINS
103143	286555	I.H.C.

*OBSOLETE SUPERSEDED BY 101556

DETAIL REFERENCE

O.E. PC. NO.	CYL HD. ASSY	AIR INLET LOCATION	INLET STR. PLATE	AIR DISCH LOCATION	GOVERNOR PORT LOCATION
286040	285776	LEFT	—	TOP	BOTH OPEN
286042	285776	LEFT	—	TOP	LEFT REAR
286103	282070	LEFT	—	LEFT	LEFT REAR
286970	282070	LEFT	238948	LEFT	LEFT REAR
101556	282070	LEFT	238948	LEFT	LEFT REAR
103143	285776	LEFT	—	TOP	BOTH OPEN

NOTE: CONN. ROD MATL. & TYPE BEARINGS USED IN REMFR. EXCH. WILL BE AT BENDIX OPTION.

REMANUFACTURED EXCH. AND CHANGEOVER SELECTIONS

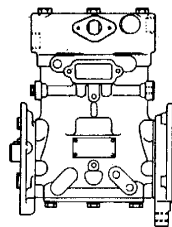

PC. NO. 286554

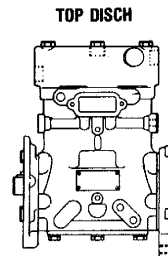

PC. NO. 286555

REMFR EXCH PC. NOS.	CHANGEOVER TO/FROM				COMPRESSOR APPLICATION	
	TU-FLO 400	TU-FLO 500	TU-FLO 600	TU-FLO 700	ENGINE	TRUCK MODEL
286554	—	284699	284714	289339	CUMMINS-NH,	VARIOUS
286555	—	284718	284720	289339	NTC, KT & KTA SERIES	

NOTE: WHEN CHANGING OVER FROM A COMPETITIVE COMPRESSOR OR ANY OTHER BENDIX COMPRESSOR, SOME DRIVE COMPONENTS MUST ALSO BE CHANGED. FOR MORE DETAILS SEE PRODUCT BULLETIN PRO-01-2.

CUMMINS FLANGE MOUNT

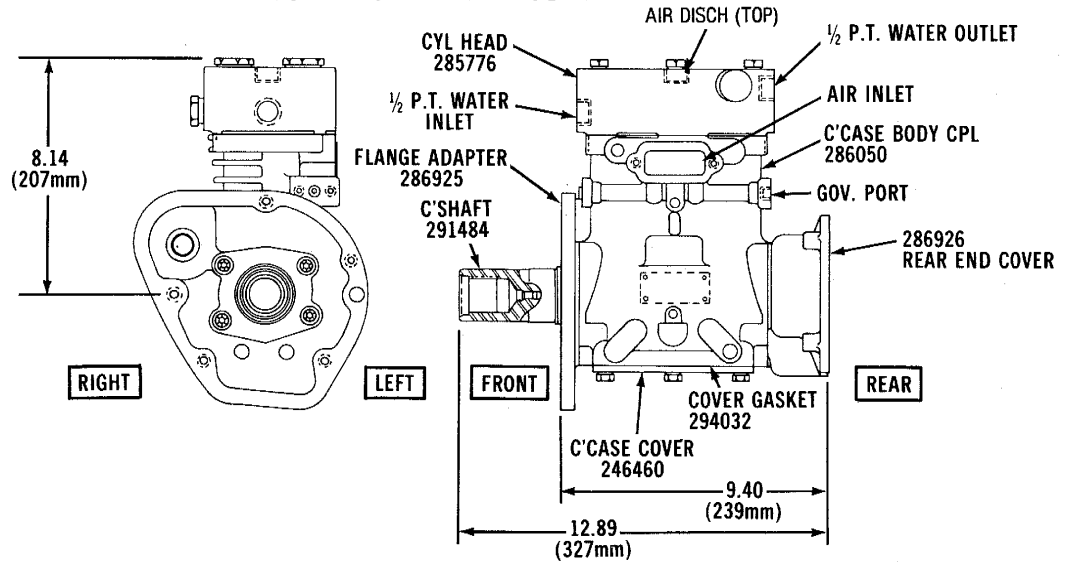

CUMMINS FLANGE MOUNT

O.E. PC. NO.	REMFR EXCH PC. NO.	PRIMARY O.E. APPLICATION
288035	286570	CUMMINS

DETAIL REFERENCE

O.E. PC. NO.	AIR INLET LOCATION	AIR INLET FITTING	AIR DISCH LOCATION	GOVERNOR PORT LOCATION	OIL INLET LOCATION
288035	LEFT	242070	TOP	LEFT REAR	C'SHAFT FRONT

REMFR EXCH & CHANGEVER SELECTIONS

REMFR EXCH PC. NO.	CHANGEVER TO/FROM				COMPRESSOR APPLICATION	
	TU-FLO 400	TU-FLO 500	TU-FLO 600	TU-FLO 700	ENGINE	TRUCK MODEL
286570	—	283711	—	101590	VT-903 & VT-350 CUMMINS	

NOTE: WHEN CHANGING OVER FROM A COMPETITIVE COMPRESSOR OR ANY OTHER BENDIX COMPRESSOR, SOME DRIVE COMPONENTS MUST ALSO BE CHANGED. FOR MORE DETAILS SEE PRODUCT BULLETIN PRO-01-2.

DETROIT DIESEL FLANGE MOUNT-0° TILT

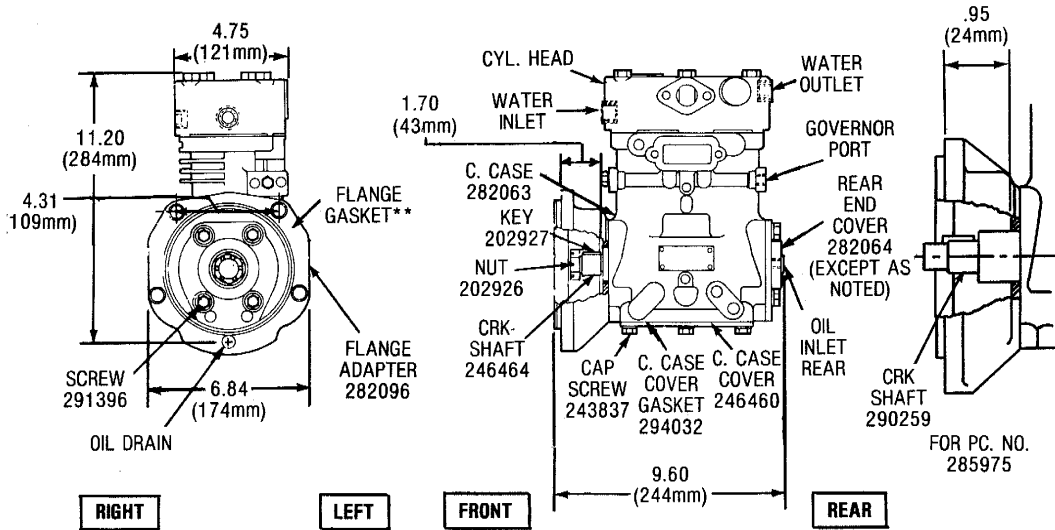

END COVER PC. NO.	NOMINAL I.D.	DESCRIPTION
282064	1.381	STANDARD
285698	1.371	REPAIR
285699	1.361	REPAIR
285700	1.351	REPAIR
101706	1.341	REPAIR
286148	1.381	STANDARD
286149	1.371	REPAIR
286150	1.361	REPAIR
286151	1.351	REPAIR
101705	1.341	REPAIR

**FLANGE GASKET IS PC. NO. 242026 FURNISHED WITH REMFR. EXCH. COMPR. MUST BE PURCHASED SEPARATELY WITH NEW COMPR.

O.E. PC. NO.	REMFR. EXCH. PC. NO.	PRIMARY O.E. APPLICATION	O.E. PC. NO.	REMFR. EXCH. PC. NO.	PRIMARY O.E. APPLICATION	O.E. PC. NO.	REMFR. EXCH. PC. NO.	PRIMARY O.E. APPLICATION
282094	SAME AS 285970 EXCEPT BENDIX IDENT		285985	286538	FORD	288320	286541	G.M.C.
285950	SAME AS 287826 EXCEPT BENDIX IDENT		285986	SAME AS 285985 EXCEPT BENDIX IDENT		288842	286581	G.M.C.
285970	286538	D.D.A.D.	285987	286538	CRANE CARRIER	289807	286538	EATON-BATAVIA
285971	286538	G.M.C.	285988	286539	FREIGHTLINER	101268	286539	DROTT
285972	286540	G.M.C.	285989	286538	EATON	101641	286539	FORD
285973	286538	G.M.C.	286066	286539	I.H.C.	101652	286539	FORD
285974	286541	G.M.C.	286200	286539	FORD	101893	286539	DROTT-J.J CASE
285975	286579	G.M.C.	286216	286538	WHITING	*102000	SAME AS 101652 EXCEPT BENDIX IDENT	
285976	286539	G.M.C.	286217	286539	WHITING	102003	SAME AS 101641 EXCEPT BENDIX IDENT	
285977	286539	D.D.A.D.	286521	286540	G.M.C.	102065	286581	G.M.C.
285978	SAME AS 285977 EXCEPT BENDIX IDENT		286637	286579	G.M.C.	102781	286538	FAIRMOUT RAILWAY
285980	286540	WHITE	286974	286539	DROTT	103130	286581	G.M.C.
285982	286540	I.H.C.	287076	286538	KERSHAW			
285983	286540	I.H.C.	287826	286541	WHITE			

*USE GOVERNOR 277192

SUB ASSEMBLY AND DETAIL REFERENCE

PC. NO.	CYL. HD. ASSEMBLY	AIR INLET		INLET SPACER	AIR OUTLET		Stud or Cap Scr. in Head (2 REQ'D.)	GOVERNOR	GOVERNOR ADAPTER OR BRACKET	WATER PORTS				OIL INLET Location
		Location	Air Strnr(S) or Fitting(F)		Discharge Location	Disch. Ftg.				Inlet	Size	Outlet	Size	
A285970	282070	LEFT	NONE	NONE	LEFT	NONE	NONE	NONE	NONE	FRONT	3/8	REAR	3/8	REAR
285971	282070	LEFT	NONE	NONE	LEFT	NONE	NONE	283593	NONE	FRONT	1/2	REAR	1/2	RIGHT
285972	285776	LEFT	279900(S)	NONE	TOP	NONE	NONE	283595	290557	RIGHT	1/2	REAR	3/8	RIGHT
285973	282070	LEFT	279900(S)	NONE	LEFT	NONE	233798	277240	NONE	FRONT	3/8	RIGHT	1/2	RIGHT
285974	285776	RIGHT	241340(F)	238948	TOP	NONE	241340	283593	NONE	REAR	1/2	FRONT	1/2	REAR
285975	285776	RIGHT	NONE	NONE	TOP	NONE	NONE	283595	290557	LEFT RR	3/8	FRONT	1/2	REAR
285976	282070	RIGHT	241340(F)	238948	RIGHT	NONE	NONE	283593	285886	LEFT RR	3/8	FRONT	1/2	REAR
285977	282070	RIGHT	NONE	NONE	RIGHT	NONE	NONE	NONE	NONE	REAR	3/8	FRONT	3/8	REAR
285980	285776	LEFT	277218(F)	238948	TOP	NONE	NONE	NONE	NONE	FRONT	1/2	REAR	1/2	RIGHT
285982	285776	LEFT	NONE	NONE	TOP	NONE	NONE	NONE	NONE	FRONT	1/2	REAR	1/2	RIGHT
285983	285776	LEFT	NONE	NONE	TOP	NONE	NONE	NONE	NONE	FRONT	1/2	REAR	1/2	RIGHT
285985	282070	LEFT	241340(F)	238948	LEFT	213042	233798	276380	NONE	REAR	3/8	FRONT	3/8	REAR
285987	282070	LEFT	279900(S)	NONE	LEFT	NONE	233798	276107	NONE	FRONT	1/2	REAR	1/2	REAR

(CONT.)

DETROIT DIESEL FLANGE MOUNT-0° TILT

SUB ASSEMBLY AND DETAIL REFERENCE

PC. NO.	CYL. HD. ASSEMBLY	AIR INLET		INLET SPACER	AIR OUTLET		Stud or Cap Scr. in Head (2 REQ'D.)	GOVERNOR	GOVERNOR ADAPTER OR BRACKET	WATER PORTS				OIL INLET Location
		Location	Air Strnr(S) or Fitting(F)		Discharge Location	Disch. Ftg.				Inlet	Size	Outlet	Size	
285988	282070	RIGHT	NONE	NONE	RIGHT	NONE	230672	NONE	NONE	REAR	1/2	FRONT	1/2	RIGHT
285989	282070	LEFT	NONE	NONE	LEFT	NONE	233798	NONE	NONE	FRONT	1/2	REAR	1/2	RIGHT
286066	282070	RIGHT	NONE	NONE	RIGHT	NONE	NONE	NONE	NONE	REAR	1/2	FRONT	1/2	RIGHT
286200	282070	RIGHT	291836(F)	238948	RIGHT	213042	233798	277192	286201	REAR	1/2	FRONT	1/2	RIGHT
286216	282070	LEFT	226464(S)	NONE	LEFT	NONE	230672	NONE	NONE	FRONT	1/2	REAR	1/2	RIGHT
286217	282070	RIGHT	226469(S)	NONE	RIGHT	NONE	230672	NONE	NONE	REAR	1/2	FRONT	1/2	RIGHT
286521	285776	LEFT	241340(F)	238948	TOP	NONE	NONE	277240	NONE	FRONT	1/2	REAR	1/2	RIGHT
286637	285776	LEFT	NONE	NONE	TOP	NONE	NONE	283593	NONE	LEFT	3/8	FRONT	1/2	RIGHT
286974	282070	LEFT	279900(S)	NONE	RIGHT	213042	233798	276102	NONE	REAR	1/2	FRONT	1/2	RIGHT
287076	282070	LEFT	246691(F)	238948	LEFT	237438	230992	276101	NONE	FRONT	1/2	REAR	1/2	RIGHT
287826	285776	RIGHT	277218(F)	238948	TOP	NONE	NONE	NONE	NONE	REAR	1/2	FRONT	1/2	RIGHT
288320	285776	RIGHT	279900(S)	NONE	TOP	NONE	NONE	283595	290557	LEFT RR.	1/2	FRONT	1/2	REAR
288842	285776	LEFT	NONE	NONE	TOP	NONE	NONE	288858	292239	FRONT	1/2	REAR	1/2	LEFT
289807	282070	LEFT	NONE	238948	LEFT	213042	233798	NONE	NONE	FRONT	1/2	REAR	1/2	RIGHT
101268	282070	RIGHT	NONE	NONE	RIGHT	213042	233798	283277	NONE	REAR	1/2	FRONT	1/2	RIGHT
101641	282070	RIGHT	241340(F)	238948	RIGHT	213042	233798	NONE	NONE	REAR	3/8	FRONT	3/8	RIGHT
101652	282070	RIGHT	291836(F)	238948	RIGHT	213042	233798	102033	286201	REAR	3/8	FRONT	3/8	RIGHT
101893	282070	RIGHT	279900(S)	NONE	RIGHT	213042	237315	NONE	NONE	REAR	1/2	FRONT	1/2	RIGHT
A102065	285776	LEFT	NONE	NONE	TOP	NONE	NONE	276106	292239	FRONT	1/2	REAR	1/2	LEFT
102781	282070	LEFT	NONE	NONE	LEFT	213041	237315	276103	NONE	FRONT	3/8	REAR	3/8	REAR
103130	285776	LEFT	NONE	NONE	TOP	NONE	NONE	276106	296064	FRONT	1/2	REAR	1/2	REAR/LEFT

A. USE REAREND COVER 286148 & REAREND COVER CAPSCREWS 246442 & 246451(2) EACH.

REMR. EXCH. & CHANGEVER SELECTIONS

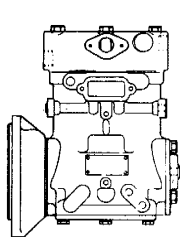

PC. NO. 286538

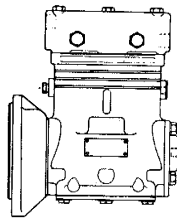

PC. NO. 286539

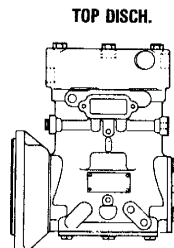

PC. NO. 286540

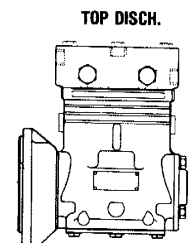

PC. NO. 286541

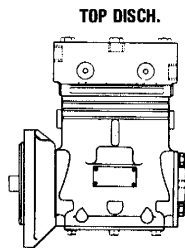

PC. NO. 286579

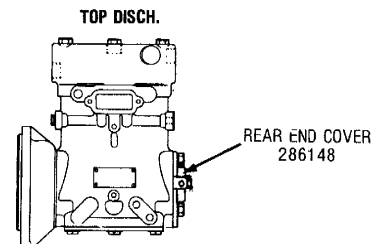

PC. NO. 286581

REMR. EXCH. PC. NOS.	CHANGEVER TO/FROM				COMPRESSOR APPLICATION	
	TU-FLO 400	TU-FLO 500	TU-FLO 600	TU-FLO 700	ENGINE	TRUCK MODEL
286538	289444	276961	284804	289925	VARIOUS (SEE NOTE B)	
286539	289508	276962	280570	289941		
286540	—	280963	281677	289925		
286541	—	282010	282011	289941		
286579	—	282928	284121	101282		
286581	—	—	—	—		

NOTE B: WILL FIT ALL D.D.A.D. ENGINES EXCEPT 8.2 LITER MODEL. ENGINE TILT AND ACCESSORIES MAY REQUIRE A DIFFERENT COMPRESSOR FLANGE ANGLE. CONSULT VEHICLE MFR. FOR MORE SPECIFIC APPLICATION.

DETROIT DIESEL FLANGE MOUNT-45° TILT

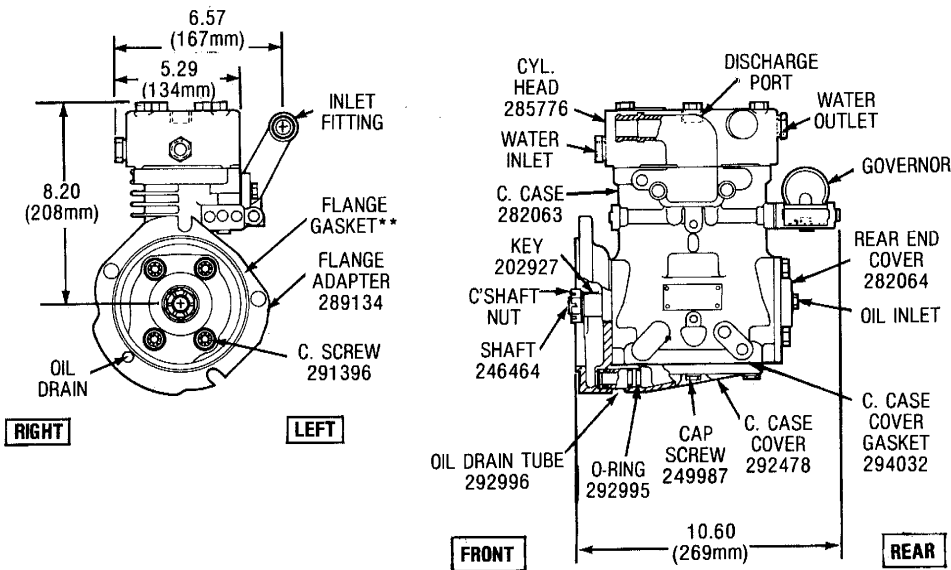

END COVER PC. NO.	NOMINAL I.D.	DESCRIPTION
282064	1.381	STANDARD
285698	1.371	REPAIR
285699	1.361	REPAIR
285700	1.351	REPAIR

**FLANGE GASKET IS PC. NO. 242026 FURNISHED WITH REMFR. EXCH. COMPR. MUST BE PURCHASED SEPARATELY WITH NEW COMPR.

O.E. PC. NO.	REMFR. EXCH. PC. NO.	PRIMARY O.E. APPLICATION
285899	286542	PETERBILT
285991	286543	D.D.A.D.
285992	286543	I.H.C.
285993	286542	WHITE
285995	286542	KENWORTH
286630	286542	G.M.C.
286660	286542	G.M.C.
287633	286543	WHITE

O.E. PC. NO.	REMFR. EXCH. PC. NO.	PRIMARY O.E. APPLICATION
287641	286542	I.H.C.
287792	286542	G.M.C.
287793	286542	G.M.C.
288674	286543	FORD
101633	286543	FORD
101656	286543	G.M.C.
102004	SAME AS 101633 EXCEPT BENDIX IDENTIFIED	
102090	286542	G.M.C.

SUB ASSEMBLY AND DETAIL REFERENCE

PC. NO.	AIR INLET		INLET SPACER	AIR OUTLET		GOVERNOR	GOVERNOR LOCATION	GOV. ADAPT. or BRACKET	Inlet	WATER PORTS		Oil Inlet Location	DRIVE Hub	C'SHAFT Nut	
	Location	Air Strnr(S) or Fitting(F)		Location	Disch. Ftg.					Size	Outlet				Size
285899	LEFT	244039(F)	238948	TOP	NONE	283594	LEFT REAR	NONE	FRONT	1/2	REAR	1/2	RIGHT	---	202926
285991	RIGHT	NONE	---	TOP	NONE	NONE	RIGHT REAR	NONE	REAR	3/8	FRONT	3/8	REAR	---	245212
285992	RIGHT	NONE	---	TOP	NONE	NONE	RIGHT REAR	NONE	REAR	1/2	FRONT	1/2	REAR	---	245212
285993	LEFT	277218(F)	238948	TOP	NONE	NONE	BOTH ENDS	NONE	FRONT	1/2	REAR	1/2	RT. & RR.	---	202926
285995	LEFT	NONE	238948	TOP	NONE	NONE	LEFT REAR	NONE	FRONT	1/2	REAR	1/2	REAR	---	202926
286630	LEFT	NONE	---	TOP	NONE	283594	LEFT REAR	NONE	FRONT	1/2	REAR	1/2	REAR	---	NONE
286660	LEFT	244039(F)	238948	TOP	NONE	283594	LEFT REAR	NONE	FRONT	3/8	REAR	3/8	RIGHT	---	NONE
287633	RIGHT	277218(F)	238948	TOP	NONE	NONE	BOTH ENDS	NONE	REAR	1/2	FRONT	1/2	RT. & RR.	---	245212
287641	LEFT	NONE	---	TOP	NONE	NONE	BOTH ENDS	NONE	FRONT	1/2	REAR	1/2	RT. & RR.	---	202926
287792	LEFT	NONE	238948	TOP	NONE	287794	LEFT REAR	291398	RT. FRT.	1/2	REAR	1/2	RIGHT	---	NONE
287793	LEFT	NONE	---	TOP	NONE	287794	REAR	291398	RIGHT	1/2	REAR	1/2	RIGHT	---	NONE
288674	RIGHT	241340(F)	238948	TOP	NONE	NONE	RIGHT REAR	NONE	REAR	3/8	FRONT	3/8	REAR	---	245212
101633	RIGHT	241340(F)	238948	TOP	NONE	NONE	RIGHT REAR	NONE	REAR	3/8	FRONT	3/8	REAR	293903	245212
101656	RIGHT	NONE	---	TOP	NONE	276108	RIGHT REAR	NONE	REAR	3/8	FRONT	3/8	REAR	NONE	245212
102090	LEFT	NONE	---	TOP	NONE	283594	LEFT REAR	NONE	FRONT	1/2	REAR	1/2	RT. REAR	NONE	NONE

DETROIT DIESEL FLANGE MOUNT-45° TILT

REMFR. EXCH. & CHANGEVER SELECTIONS

TOP DISCH.

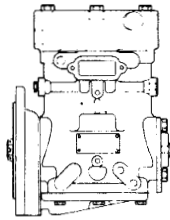

PC. NO. 286542

TOP DISCH.

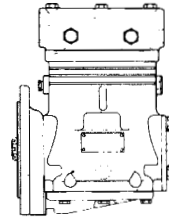

PC. NO. 286543

REMFR. EXCH. PC. NOS.	CHANGEVER TO/FROM				COMPRESSOR APPLICATION	
	TU-FLO 400	TU-FLO 500	TU-FLO 600	TU-FLO 700	ENGINE	TRUCK MODEL
286542		281042	282013	289342	VARIOUS (SEE NOTE A)	
286543		285252	289793	101158		

NOTE A: WILL FIT ALL D.D.A.D. ENGINES EXCEPT 8.2 LITER MODEL. ENGINE TILT AND ACCESSORIES MAY REQUIRE A DIFFERENT COMPRESSOR FLANGE ANGLE. CONSULT VEHICLE MFR. FOR MORE SPECIFIC APPLICATION.

Piece Number	Optional Piece Number(s)
101268	285976, 285977, 285978, 285988, 286066, 286217, 286974, 101641 101652, 101893
101519	289043, 288071, 102656, 102691, 102797, 102327, 102328
101556	286103, 286970
101588	—
101608	286029, 287605, 288906, 288951
101633	285991, 285992, 287633, 101656
101641	285976, 285977, 285978, 285988, 286066, 286217, 286974, 101268 101652, 101893
101652	285976, 285977, 285978, 285988, 286066, 286217, 286974, 101268 101641, 101893
101656	285991, 285992, 287633, 101633
101893	285976, 285977, 285978, 285988, 286066, 286217, 286974, 101268 101641, 101652
101894	285937, 285943, 289097
101904	289015, 102091
101911	288982, 101912
101912	288982, 101911
102002	289121
102065	288842
102077	102078
102090	285899, 285993, 285995, 286630, 286660, 287641, 287792, 287793
102091	289015, 101904
102327	288071, 289043, 101519, 102656, 102691, 102797, 102328
102328	288071, 289043, 101519, 102656, 102691, 102797, 102327
102640	286017
102651	285952, 285957, 285961, 285962, 285963, 285964, 286133, 286692 286767, 286872, 288060, 288061
102656	289043, 288071, 101519, 102691, 102797, 102327, 102328
102658	102696
102688	102695
102691	289043, 288071, 101519, 102656, 102797, 102327, 102328
102695	102688
102696	102658
102726	—
102743	102764
102764	102743
102769	—
102781	282094, 285970, 285971, 285973, 285985, 285987, 285989
102797	289043, 288071, 101519, 102656, 102691, 102327, 102328
102822	289751

Piece Number	Optional Piece Number(s)
102991	286104
282094	285970, 285971, 285973, 285987, 285989, 286216, 287076, 289807 102781
285861	286514, 287629, 288658
285862	285923
285872	286662
285876	285927
285899	285993, 285995, 286630, 286660, 287641, 287792, 287793, 102090
285923	285862
285924	285928
285925	285967
285927	285876
285928	285924
285930	285953, 285955, 285959, 285965, 285966, 286128, 286131, 286134 286218, 286641, 286684, 287303, 287483, 288062, 288974
285937	285943, 289097, 101894,
285939	285942
285941	—
285942	285939
285943	285937, 289097, 101894,
285947	288294
285948	285949, 285951
285949	285948, 285951
285950	285974, 287826, 288320
285951	285948, 285949
285952	285957, 285961, 285962, 285963, 285964, 286133, 286692, 286767 286872, 288060, 288061, 102651
285953	285930, 285955, 285959, 285965, 285966, 286128, 286131, 286134 286218, 286641, 286684, 287303, 287483, 288062, 288974
285955	285930, 285953, 285959, 285965, 285966, 286128, 286131, 286134 286218, 286641, 286684, 287303, 287483, 288062, 288974
285957	285952, 285961, 285962, 285963, 285964, 286133, 286692, 286767 286872, 288060, 288061, 102651
285959	285930, 285953, 285955, 285965, 285966, 286128, 286131, 286134 286218, 286641, 286684, 287303, 287483, 288062, 288974
285960	—
285961	285952, 285957, 285962, 285963, 285964, 286133, 286692, 286767 286872, 288060, 288061, 102651
285962	285952, 285957, 285961, 285963, 285964, 286133, 286692, 286767 286872, 288060, 288061, 102651

Piece Number	Optional Piece Number(s)
285963	285952, 285957, 285961, 285962, 285964, 286133, 286692, 286767 286872, 288060, 288061, 102651
285964	285952, 285957, 285961, 285962, 285963, 286133, 286692, 286767 286872, 288060, 288061, 102651
285965	285930, 285953, 285955, 285959, 285966, 286128, 286131, 286134 286218, 286641, 286684, 287303, 287483, 288062, 288974
285966	285930, 285953, 285955, 285959, 285965, 286128, 286131, 286134 286218, 286641, 286684, 287303, 287483, 288062, 288974
285967	285925
285969*	285937, 285943, 289097, 101894,
285970	282094, 285971, 285973, 285987, 285989, 286216, 287076, 289807 102781
285971	282094, 285970, 285973, 285987, 285989, 286216, 287076, 289807 102781
285972	285980, 285982, 285983, 286521
285973	282094, 285970, 285971, 285987, 285989, 286216, 287076, 289807 102781
285974	285950, 287826, 288320
285975	286637
285976	285977, 285978, 285988, 286066, 286217, 286974, 101268, 101641 101652, 101893
285977	285976, 285978, 285988, 286066, 286217, 286974, 101268, 101641 101652, 101893
285978	285976, 285977, 285988, 286066, 286217, 286974, 101268, 101641 101652, 101893
285980	285972, 285982, 285983, 286521
285981*	285972, 285980, 285982, 285983, 286521
285982	285972, 285980, 285983, 286521
285983	285972, 285980, 285982, 286521
285984*	285976, 285977, 285978, 285988, 286066, 286217, 286974, 101268 101641, 101652, 101893
285985*	282094, 285970, 285971, 285973, 285987, 285989, 286216, 287076 289807, 102781
285987	282094, 285970, 285971, 28597 285989, 286216, 287076, 28980. 102781
285988	285976, 285977, 285978, 286066, 286217, 286974, 101268, 101641 101652, 101893

*Obsolete

TU-FLO 501 COMPRESSORS

Piece Number	Optional Piece Number(s)
285989	282094, 285970, 285971, 285973, 285987, 286216, 287076, 289807, 102781
285991	285992, 287633, 101633, 101656
285992	285991, 287633, 101633, 101656
285993	285899, 285995, 286630, 286660, 287641, 287792, 287793, 102090
285995	285899, 285993, 286630, 286660, 287641, 287792, 287793, 102090
286004*	286005
286005*	286004
286006	286007
286007	286006
286008	286011, 286012
286009	288087
286011	286008, 286012
286012	286008, 286011
286014	—
286017	102640
286019	286020
286020	286019
286021	286022
286022	286021
286023	286024
286024	286023
286025	286026
286026	286025
286027	286028
286028	286027
286029	287605, 288906, 288951, 101608
286030	286031
286031	286030
286037	286103, 286970, 101556
286040	286042
286042	286040
286066	285976, 285977, 285978, 285988, 286217, 286974, 101268, 101641, 101652, 101893
286103	286970, 101556
286104	102991
286105	—
286106	—
286119*	286105
286121*	286106
286128	285930, 285953, 285955, 285959, 285965, 285966, 286131, 286134, 286218, 286641, 286684, 287303, 287483, 288062, 288974
286131	285930, 285953, 285955, 285959, 285965, 285966, 286128, 286134, 286218, 286641, 286684, 287303, 287483, 288062, 288974

Piece Number	Optional Piece Number(s)
286133	285952, 285957, 285961, 285962, 285963, 285964, 286692, 286767, 286872, 288060, 288061, 102651
286134	285930, 285953, 285955, 285959, 285965, 285966, 286128, 286131, 286218, 286641, 286684, 287303, 287483, 288062, 288974
286145*	286574
286200*	285976, 285977, 285978, 285988, 286066, 286217, 286974, 101268, 101641, 101652, 101893
286216	282094, 285970, 285971, 285973, 285987, 285989, 287076, 289807, 102781
286217	285976, 285977, 285978, 285988, 286066, 286974, 101268, 101641, 101652, 101893
286218	285930, 285953, 285955, 285959, 285965, 285966, 286128, 286131, 286134, 286641, 286684, 287303, 287483, 288062, 288974
286514	285861, 287629, 288658
286521	285972, 285980, 285982, 285983
286574	286145
286630	285899, 285993, 285995, 286660, 287641, 287792, 287793, 102090
286637	285975
286640*	285960
286641	285930, 285953, 285955, 285959, 285965, 285966, 286128, 286131, 286134, 286218, 286641, 286684, 287303, 287483, 288062, 288974
286642*	285930, 285953, 285955, 285959, 285965, 285966, 286128, 286131, 286134, 286218, 286641, 286684, 287303, 287483, 288062, 288974
286650*	286029, 287605, 288906, 288951, 101608
286660	285899, 285993, 285995, 286630, 287641, 287792, 287793, 102090
286662	285872
286683*	285937, 285943, 289097, 101894, 102822
286684	285930, 285953, 285955, 285959, 285965, 285966, 286128, 286131, 286134, 286218, 286641, 287303, 287483, 288062, 288974
286692	285952, 285957, 285961, 285962, 285963, 285964, 286133, 286767, 286872, 288060, 288061, 102651
286767	285952, 285957, 285961, 285962, 285963, 285964, 286133, 286692, 286872, 288060, 288061, 102651
286872	285952, 285957, 285961, 285962, 285963, 285964, 286133, 286692, 286767, 288060, 288061, 102651
286884	286885
286885	286884

Piece Number	Optional Piece Number(s)
286970	286103, 101556
286974	285976, 285977, 285978, 285988, 286066, 286217, 101268, 101641, 101652, 101893
287034	—
287076	282094, 285970, 285971, 285973, 285987, 285989, 286216, 289807, 102781
287109*	285872
287303	285930, 285953, 285955, 285959, 285965, 285966, 286128, 286131, 286134, 286218, 286641, 286684, 287483, 288062, 288974
287483	285930, 285953, 285955, 285959, 285965, 285966, 286128, 286131, 286134, 286218, 286641, 286684, 287303, 288062, 288974
287605	286029, 288906, 288951, 101608
287609	287610
287610	287609
287629	285861, 286514, 288658
287631	287632
287632	287631
287633	285991, 285992, 101633, 101656
287641	285899, 285993, 285995, 286630, 286660, 287792, 287793, 102090
287792	285899, 285993, 285995, 286630, 286660, 287641, 287793, 102090
287793	285899, 285993, 285995, 286630, 286660, 287641, 287792, 102090
287826	285950, 285974, 288320
288035	—
288060	285952, 285957, 285961, 285962, 285963, 285964, 286133, 286692, 286767, 286872, 288061, 102651
288061	285952, 285957, 285961, 285962, 285963, 285964, 286133, 286692, 286767, 286872, 288060, 102651
288062	285930, 285953, 285955, 285959, 285965, 285966, 286128, 286131, 286134, 286218, 286641, 286684, 287303, 287483, 288974
288071	289043, 101519, 102656, 102691, 102797, 102327, 102328
288087	286009
288294	285947
288302	—
288320	285950, 285974, 287826
288642*	285930, 285953, 285955, 285959, 285965, 285966, 286128, 286131, 286134, 286218, 286641, 286684, 287303, 287483, 288062, 288974
288658	285861, 286514, 287629
288674*	285991, 285992, 287633, 101633, 101656
288693	—

*Obsolete

TU-FLO 501 COMPRESSORS

SERVICE PARTS
CATALOG 01-E-22

288842	102065
288906	286029, 287605, 288951, 101608
288942	—
288951	286029, 287605, 288906, 101608
288974	285930, 285953, 285955, 285959, 285965, 285966, 286128, 286131 286134, 286218, 286641, 286684, 287303, 287483, 288062
288982	101911, 101912
289015	101904, 102091
289043	288071, 101519, 102656, 102691 102797, 102327, 102328
289097	285937, 285943, 101894, 101822
289121	102002
289261	—
289620*	—
289751	102822
289807	282094, 285970, 285971, 285973, 285987, 285989, 286216, 287076 102781

501 NUMERICAL INDEX

O.E. NO.	REMFR. EXCH. NO.	PAGE NO.	O.E. NO.	REMFR. EXCH. NO.	PAGE NO.	O.E. NO.	REMFR. EXCH. NO.	PAGE NO.	O.E. NO.	REMFR. EXCH. NO.	PAGE NO.
282094	286538	01-E-16	286017	286580	01-E-5	*286566	286566	01-E-10	288982	286544	01-E-10
285861	286528	01-E-5	286018	286580	01-E-5	*286567	286567	01-E-5	289015	286591	01-E-5
285862	286576	01-E-5	286019	286547	01-E-10	*286570	286570	01-E-15	289043	286584	01-E-13
285868	286556	01-E-8	286020	286547	01-E-10	*286571	286571	01-E-10	289097	286535	01-E-5
285872	286530	01-E-4	286021	286548	01-E-10	*286572	286572	01-E-10	289121	286585	01-E-5
285876	286558	01-E-9	286022	286548	01-E-10	*286574	286574	01-E-12	289261	286593	01-E-10
285878	286546	01-E-10	286023	286549	01-E-10	*286576	286576	01-E-5	289751	286592	01-E-5
285899	286542	01-E-18	286024	286549	01-E-10	*286578	286578	01-E-5	289807	286538	01-E-16
285923	286576	01-E-5	286025	286550	01-E-10	*286579	286579	01-E-16			
285924	286578	01-E-5	286026	286550	01-E-10	*286580	286580	01-E-5	101268	286539	01-E-16
285925	286536	01-E-5	286027	286551	01-E-10	*286581	286581	01-E-16	101519	286584	01-E-13
285927	286558	01-E-9	286028	286552	01-E-10	*286582	286582	01-E-5	101556	286554	01-E-14
285928	286578	01-E-5	286029	286546	01-E-10	*286584	286584	01-E-13	101588	286595	01-E-5
285929	286535	01-E-5	286030	286552	01-E-10	*286585	286585	01-E-5	101608	286546	01-E-10
285930	286526	01-E-5	286031	286552	01-E-10	*286586	286586	01-E-5	101633	286543	01-E-18
285932	286527	01-E-5	286037	286554	01-E-14	*286589	286589	01-E-5	101641	286539	01-E-16
285937	286535	01-E-5	286040	286555	01-E-14	*286591	286591	01-E-5	101652	286539	01-E-16
285941	286537	01-E-5	286042	286555	01-E-14	*286592	286592	01-E-5	101656	286543	01-E-18
285942	286532	01-E-4	286066	286539	01-E-16	*286593	286593	01-E-10	101893	286539	01-E-16
285943	286535	01-E-5	286103	286554	01-E-14	*286595	286595	01-E-5	101894	286535	01-E-5
285947	286533	01-E-4	286104	286563	01-E-10	*286596	286596	01-E-12	101904	286591	01-E-5
285948	286529	01-E-5	286105	286572	01-E-10	286630	286542	01-E-18	101936	286591	01-E-5
285949	286529	01-E-5	286106	286571	01-E-10	286637	286579	01-E-16	102000	286539	01-E-16
285950	286541	01-E-16	286128	286526	01-E-5	286641	286526	01-E-5	102001	286591	01-E-5
285951	286529	01-E-5	286131	286526	01-E-5	286660	286542	01-E-18	102002	286585	01-E-5
285952	286527	01-E-5	286133	286527	01-E-5	286662	286530	01-E-4	102003	286539	01-E-16
285953	286526	01-E-5	286134	286526	01-E-5	286663	286532	01-E-4	102004	286543	01-E-18
285954	286526	01-E-5	286145	286574	01-E-12	286664	286533	01-E-4	102065	286581	01-E-16
285955	286526	01-E-5	286200	286539	01-E-16	286684	286526	01-E-5	102077	286596	01-E-12
285957	286527	01-E-5	286216	286538	01-E-16	286692	286527	01-E-5	102078	286596	01-E-12
285959	286526	01-E-5	286217	286539	01-E-16	286767	286527	01-E-5	102090	286542	01-E-18
285960	286560	01-E-5	286218	286526	01-E-5	286872	286527	01-E-5	102091	286591	01-E-5
285961	286527	01-E-5	286514	286528	01-E-5	286884	286562	01-E-9	102092	286591	01-E-5
285962	286527	01-E-5	286521	286540	01-E-16	286885	286562	01-E-9	102640	286580	01-E-5
285963	286527	01-E-5	*286526	286526	01-E-5	286897	286554	01-E-14	102651	286527	01-E-5
285964	286527	01-E-5	*286527	286527	01-E-5	286974	286539	01-E-16	102656	286584	01-E-13
285965	286526	01-E-5	*286528	286528	01-E-5	287034	286564	01-E-8	102658	102697	01-E-10
285966	286526	01-E-5	*286529	286529	01-E-5	287076	286538	01-E-16	102688	102698	01-E-5
285967	286536	01-E-5	*286530	286530	01-E-4	287303	286526	01-E-5	102691	286584	01-E-13
285970	286538	01-E-16	*286532	286532	01-E-4	287483	286526	01-E-5	102695	102698	01-E-5
285971	286538	01-E-16	*286533	286533	01-E-4	287605	286546	01-E-10	102696	102697	01-E-10
285972	286540	01-E-16	*286535	286535	01-E-5	287609	286566	01-E-10	*102697	102697	01-E-10
285973	286538	01-E-16	*286536	286536	01-E-5	287610	286566	01-E-10	*102698	102698	01-E-5
285974	286541	01-E-16	*286537	286537	01-E-5	287629	286528	01-E-5	102726	102734	01-E-8
285975	286579	01-E-16	*286538	286538	01-E-16	287631	286567	01-E-5	*102734	102734	01-E-8
285976	286539	01-E-16	*286539	286539	01-E-16	287632	286567	01-E-5	*102742	102742	01-E-13
285977	286539	01-E-16	*286540	286540	01-E-16	287633	286543	01-E-18	102743	102742	01-E-13
285978	286539	01-E-16	*286541	286541	01-E-16	287641	286542	01-E-18	102764	102742	01-E-13
285980	286540	01-E-16	*286542	286542	01-E-18	287792	286542	01-E-18	102769	102785	01-E-10
285982	286540	01-E-16	*286543	286543	01-E-18	287793	286542	01-E-18	102781	286538	01-E-16
285983	286540	01-E-16	*286544	286544	01-E-10	287826	286541	01-E-16	*102785	102785	01-E-10
285984	286539	01-E-16	*286546	286546	01-E-10	288035	286570	01-E-15	102797	286584	01-E-13
285985	286538	01-E-16	*286547	286547	01-E-10	288060	286527	01-E-5	102822	286592	01-E-5
285986	286538	01-E-16	*286548	286548	01-E-10	288061	286527	01-E-5	102870	102953	01-E-12
285987	286538	01-E-16	*286549	286549	01-E-10	288062	286526	01-E-5	*102953	102953	01-E-12
285988	286539	01-E-16	*286550	286550	01-E-10	288071	286584	01-E-13	102954	102953	01-E-12
285989	286538	01-E-16	*286551	286551	01-E-10	288087	286565	01-E-8	102987	102989	01-E-5
285991	286543	01-E-18	*286552	286552	01-E-10	288088	286565	01-E-8	102988	102989	01-E-5
285992	286543	01-E-18	*286554	286554	01-E-14	288294	286533	01-E-4	*102989	102989	01-E-5
285993	286542	01-E-18	*286555	286555	01-E-14	288302	286589	01-E-5	102991	286563	01-E-10
285995	286542	01-E-18	*286556	286556	01-E-8	288320	286541	01-E-16	103071	286591	01-E-5
286006	286561	01-E-9	*286557	286557	01-E-8	288658	286528	01-E-5	103072	286591	01-E-5
286007	286561	01-E-9	*286558	286558	01-E-9	288674	286543	01-E-18	103130	286581	01-E-16
286008	286556	01-E-8	*286560	286560	01-E-5	288693	286586	01-E-5	103143	286555	01-E-14
286009	286565	01-E-8	*286561	286561	01-E-9	288842	286581	01-E-16	103167	103274	01-E-10
286010	286565	01-E-8	*286562	286562	01-E-9	288906	286546	01-E-10	*103273	103274	01-E-10
286011	286556	01-E-8	*286563	286563	01-E-10	288942	286582	01-E-5	*103274	103274	01-E-10
286012	286556	01-E-8	*286564	286564	01-E-8	288951	286546	01-E-10	103890	286591	01-E-5
286014	286557	01-E-8	*286565	286565	01-E-8	288974	286526	01-E-5	103952	286539	01-E-16