



SENTINEL[®] TECHNOLOGY

**Extend Seal & Bearing Life
By Preventing
Contamination**

Sentinel[®] Technology provides an unmatched filtering system to eliminate contamination of lubricant from grime, dirt or water. STEMCO provides four options to put Sentinel[®] Technology to work for you: the Sentinel[®] Hub Cap, Sentinel[®] ESP, the Sentinel[®] ESP Filtered Vent and Integrated Sentinel[®] Hub Cap.

SENTINEL[®] Hub Cap

The Sentinel[®] Hub Cap provides a tamper-proof system for maximum protection and maintenance-free performance.

SENTINEL[®] ESP (Extended Service Plug)

The Sentinel[®] ESP allows economical retrofitting of wheel ends with the benefits of STEMCO'S exclusive Sentinel[®] Technology.

SENTINEL[®] ESP Filtered Vent

Drive axles can now be retrofitted to benefit from STEMCO'S exclusive Sentinel[®] Technology.

SENTINEL[®] Integrated Hub Cap

The newest product in the Sentinel[®] family, this tamper-proof hub cap integrates the Sentinel[®] features into the window with fewer components and greater wheel end visibility.



STEMCO[®]

A Higher Standard of Performance.SM

SENTINEL®

☉ Sentinel® Technology prevents dirt and water from contaminating the oil, thereby extending seal and bearing life.

☉ Sentinel® Technology dramatically reduces contaminant build-up on hub cap windows, allowing for an accurate determination of lube levels.

☉ Sentinel® Technology eliminates early oil breakdown by preventing water contamination as a result of submerged axles.

☉ Sentinel® Technology provides maximum protection for maintenance-free wheel end systems.

☉ Sentinel® Technology improves performance and lowers overall maintenance costs.

Sentinel® ESP (Extended Service Plug)

STEMCO PART NO.	DESCRIPTION
359-6124	ESP Plug Blister Pack (2/pk)
359-6125	ESP Plugs (bulk pack of 50)

Sentinel® ESP Filtered Vent

STEMCO PART NO.	DESCRIPTION
359-6137	Drive Axle Vent (3/8" adapter)

Bulk Pack Hub Cap

STEMCO PART NO.	DESCRIPTION
300-5009	340-4009 Hub Cap with ESP Plug Bulk Pack (50/box)
303-5009	343-4009 Hub Cap with ESP Plug Bulk Pack (50/box)

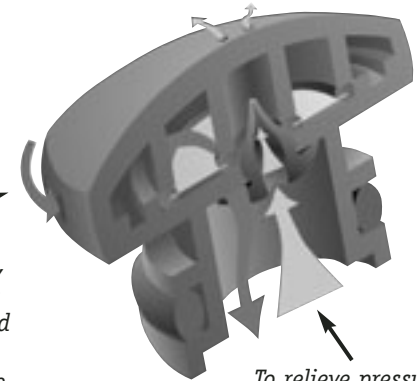

To relieve vacuum, the Sentinel® interior check valve lifts slightly, drawing air through the water-resistant expanded PTFE fabric filter into the wheel end, while the duck-bill check valve remains closed, blocking dirt, grime and other contaminants from entering.

To relieve pressure, the Sentinel® duck-billed pressure relief valve opens, allowing pressure to vent out, while the umbrella check valve remains closed, stopping lubricant from leaking out and contaminants from flowing in.

Sentinel® Hub Cap

STEMCO BASE PART NO.	OIL CAP	GREASE CAP	BOLT CIRCLE	BOLT SIZE	NO. OF BOLTS	GASKET NUMBER	OIL WINDOW KIT	GREASE WINDOW KIT
4009	348-4009	349-4009	5 1/2"	5/16"	6	330-3009	359-6112	359-6120
4013	348-4013	349-4013	5 1/2"	5/16"	5	330-3013	359-6112	359-6120
4046	348-4046	349-4046	5 1/2"	5/16"	6	330-3009	359-6112	359-6120
4075	348-4075	349-4075	6 1/4" x 8" UN(M)			330-3077	359-6112	359-6120
4095	348-4095	349-4095	5 1/2"	5/16"	6	330-3009	359-6112	359-6120
4195	348-4195	349-4195	6 3/4"	5/16"	6	330-3118	359-6112	359-6120
4281	348-4281	349-4281	5 17/32"	3/8"	6	330-3122	359-6112	359-6120

Integrated Sentinel® Hub Cap

STEMCO BASE PART NO.	OIL CAP	GREASE CAP	BOLT CIRCLE	BOLT SIZE	NO. OF BOLTS	GASKET NUMBER	OIL WINDOW KIT	GREASE WINDOW KIT
4009	356-4009	358-4009	5 1/2"	5/16"	6	330-3009	359-6145	359-6146
4013	356-4013	358-4013	5 1/2"	5/16"	5	330-3013	359-6145	359-6146
4024	356-4024	358-4024	4 1/2"	5/16"	6	330-3024	359-6143	359-6144
4025	356-4025	358-4025	5 7/8"	5/16"	6	330-3025	359-6143	359-6144
4046	356-4046	358-4046	5 1/2"	5/16"	6	330-3009	359-6145	359-6146
4075	356-4075	358-4075	6 1/4" x 8" UN(M)			330-3077	359-6145	359-6146
4080	356-4080	358-4080	6	3/8"	6	330-3060	359-6143	359-6144
4095	356-4095	358-4095	5 1/2"	5/16"	6	330-3009	359-6145	359-6146
4119	356-4119	358-4119	7	5/8"	8	330-3090	359-6145	359-6146
4150	356-4150	358-4150	4 1/2"	5/16"	5	330-3150	359-6143	359-6144
4195	356-4195	358-4195	6 3/4"	5/16"	6	330-3118	359-6145	359-6146



STEMCO®

A Higher Standard of Performance.™

QS 9000 & ISO 9001
STEMCO and Sentinel are trademarks of STEMCO LLC
©2002 STEMCO LLC

STEMCO - USA
P.O. Box 1989 • Longview, TX 75606-1989
(903) 758-9981 • 1-800-527-8492 • FAX: 1-800-874-4297
www.stemco.com

STEMCO - Canada
5900 Ambler Drive, Units 4 & 5 • Mississauga, ON L4W 2N3
(905) 206-9922 • 877-232-9111 • FAX: 877-244-4555



Printed in the USA
Part No. 571-3038
Hudson-10-483 • Rev. 5/02

Hub Cap Specifications

Hub Caps By Cap Number

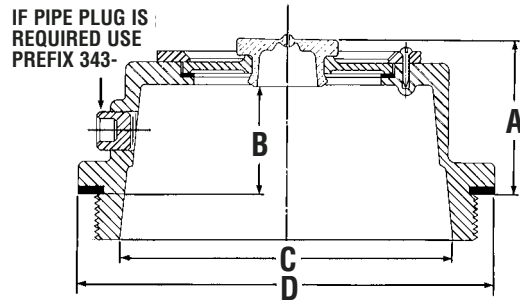
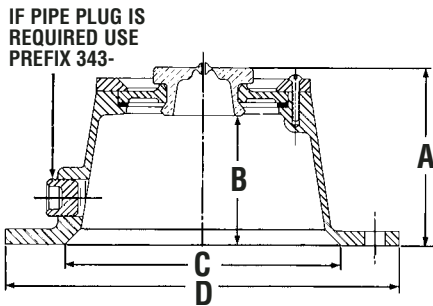

Hub Cap Includes Gasket	Bolt Circle	Bolt Size	No. Of Bolts	A Height	B Inside Depth	C Flange I.D.	D Flange O.D.	Gasket Number	Window Kit
340-4002	5-1/4	3/8	3	2-7/8	2-1/8	4-3/8	6	330-3002	359-5999
340-4009 ☐	5-1/2	5/16	6	2-11/16	1-15/16	4-3/8	6-1/4	330-3009	359-5995
340-4011	6-1/8	3/8	3	2-11/16	1-15/16	4-5/16	7	330-3011	359-5995
340-4013 ☐	5-1/2	5/16	5	2-11/16	1-15/16	4-3/8	6-1/4	330-3013	359-5995
340-4015	Blank	--	--	2-11/16	1-15/16	4-3/8	6-1/4	330-3015	359-5995
340-4019	5-1/4	3/8	3	3-1/2	2-3/4	4-1/8	Not Round	330-3019	359-5995
340-4024	4-1/2	5/16	6	2-5/8	1-7/8	3-1/2	5-1/4	330-3024	359-5999
343-4025 ☐	5-7/8	5/16	6	1-3/8	5/8	4-1/4	6-1/2	330-3025	359-5999
340-4028	5	1/4	4	3-1/8	2-3/8	4	5-3/4	330-3028	359-5999
340-4031	5-1/4	5/16	6	2-7/8	2-1/8	4-3/8	6	330-3031	359-5999
340-4034	6-5/8	1/4	6	2-13/16	2-1/16	5-5/16	7-1/8	330-3034	359-5999
340-4036	5-7/8	5/16	6	2-3/8	1-5/8	5-1/8	Not Round	330-3035	359-5995
340-4042	5-1/8	5/16	6	1-7/8	1-1/8	4	5-11/16	330-3041	359-5999
340-4046	5-1/2	5/16	6	2-5/16	1-9/16	4-9/16	6-3/16	330-3009	359-5995
340-4049	5-9/16	5/16	3	2-7/8	2-1/8	3-3/4	6-3/8	330-3042	359-5999
340-4054 ☐	Blank	None	--	2-1/8	1-3/8	4-1/32	8-5/8	330-3017	359-5995
340-4059	6	5/16	6	2-5/8	1-7/8	5	6-3/4	330-3056	359-5995
343-4064 ☐	6-3/4	3/8	6	2-11/16	1-15/16	5	7-3/4	330-3079	359-5995
340-4065	3-5/8	5/16	4	2-1/4	1-1/2	2-3/4	4-1/2	330-3040	359-5990
340-4066	5-1/8	5/16	6	2-7/8	2-1/8	3-3/4	5-3/4	330-3041	359-5999
340-4075 ☐	6-1/4 X 8 UN (M)			2-5/16	1-9/16	5-3/4	6-7/8	330-3077	359-5995
343-4080 ☐	6	3/8	6	3-3/16	2-3/8	4-15/16	6-7/8	330-3060	359-5999
340-4082	6-7/8	7/16	7	2-11/16	1-15/16	5	7-3/4	330-3062	359-5995
340-4092	5-7/8	5/16	6	1-5/8	1-7/16	4-1/2	6-37/64	330-3025	359-5912
340-4095	5-1/2	5/16	6	1-13/16	1-1/16	4-9/16	6-3/16	330-3009	359-5995
340-4098	5-1/2	5/16	6	1-1/4	1-1/8	4-7/16	6-3/16	330-3009	359-5912
343-4107 ☐	7-1/4	1/4	6	2-7/8	2-1/8	6-1/4	7-7/8	330-3084	359-5995
340-4119 ☐	7	5/8	8	2-1/16	1-5/16	4-5/16	8-1/4	330-3090	359-5995
343-4122 ☐	5-1/2	5/16	6	2-11/16	1-15/16	4-3/8	6-1/4	330-3009	359-5995
340-4139 ☐	4-1/16	3/16	6	2-5/8	1-7/8	3-5/16	4-1/2	330-3094	359-5999

























(Continued Next Page)

- ☐ Cannot be made with pipe plug.
- ☑ Made with pipe plug only.
- ☒ Hub cap available with hubo window, order 347-prefix. Also available **347-4342**, which is 4195 hub cap for grease applications and **347-4343** which is 4075 hub cap for grease applications, **347-4278** for 4009 grease hub cap application.
- ☑ 4009 hub cap with magnetic pipe plug (**359-5984**).

COMPONENT SPECIFICATIONS

Hub Cap Specifications

Hub Caps By Cap Number

Hub Cap Includes Gasket	Bolt Circle	Bolt Size	No. Of Bolts	A Height	B Inside Depth	C Flange I.D.	D Flange O.D.	Gasket Number	Window Kit
340-4149	5-9/16	5/16	6	2-7/8	2-1/8	3-11/16	6-3/8	330-3097	359-5999
340-4150	4-1/2	5/16	5	2-5/8	1-7/8	3-1/2	5-1/4	330-3150	359-5999
340-4157 	4	1/4	4	2-1/8	1-3/8	3-1/8	4-9/16	330-3102	NONE
340-4163 	6-1/8	5/16	6	2-11/16	1-15/16	4-5/16	7	330-3104	359-5995
343-4176	5-1/2	5/16	6	2-1/2	1-3/4	4-15/16	6-7/8	330-3060	359-5999
340-4186	5	5/16	4	2-1/8	1-3/8	4	5-3/4	330-3120	359-5999
340-4195 	6-3/4	5/16	6	3-11/16	2-15/16	5-7/16	7-1/2	330-3118	359-5995
340-4198	3-7/8	5/16	6	2-1/4	1-1/2	2-3/4	4-1/2	330-3119	NONE
340-4249 	5-1/2	5/16	6	1-13/16	1-11/16	4-7/16	6-3/16	330-3122	359-5912
343-4250  	5-17/32	3/8	6	1-13/16	1-9/16	4-7/16	6-3/16	330-3122	NONE
340-4263 	4-1/2	6mm	6	2-5/8	1-7/8	3-1/2	5-1/4	330-3024	359-5999
343-4264 	5-1/2	5/16	6	1-5/8	1-1/16	4-9/16	6-3/16	330-3009	359-5995
343-4269 	132mm	8.5mm	6	63.5mm	53.4mm	106mm	156mm	330-3128	359-6100
343-4281 	5-17/32	3/8	6	2-5/16	1-9/16	4-9/16	6-3/16	330-3122	359-5995
343-4295 	110mm	8.5mm	6	67.3mm	47.0mm	88.4mm	133.3mm	330-3130	359-5999
340-4305 	7	13/16	8	2-1/16	1-5/16	4-5/16	8-1/4	330-3107	359-5995
343-4308  	4-1/2	5/16	6	2-5/8	1-7/8	3-1/2	5-1/4	330-3024	NONE
343-4309  	5-1/2	5/16	6	1-13/16	1-1/16	4-9/16	6-3/16	330-3009	359-6100
340-4320 	6-1/4 X 8 UN (M)			2-5/16	1-9/16	5-3/4	6-7/8	330-3077	NONE
343-4342  	5-1/2	5/16	6	2-11/16	1-15/16	4-3/8	6-1/4	330-3009	359-6100
340-4975  	6-1/4 X 8 UN (M)			2-5/16	1-9/16	5-3/4	6-7/8	330-3077	NONE
340-4976  	6-1/4 X 8 UN (M)			2-5/16	1-9/16	5-3/4	6-7/8	330-3077	NONE
340-4977 	6-1/4 X 8 UN (M)			2-5/16	1-9/16	5-3/4	6-7/8	330-3077	NONE

 Cannot be made with pipe plug.

 Made with pipe plug only.

 Hub cap can be used with 5-1/2 or 5-9/16 bolt circle with 5/16 inch bolts.

 Hub cap available with hubo window, order 347-prefix. Also available **347-4342**, which is 4195 hub cap for grease applications, **347-4343** which is 4075 hub cap for grease applications and **347-4278** which is 4009 hub cap for grease applications.

 Lexan hub caps, order in multiples of 25.

 4249 with recessed vent plug.

 4095 with small vent plug **359-5915**.

 4009 with small vent plug **359-5915**.

 4024 with small vent plug.

 4975 individually boxed.

Torque Specifications

Threaded Hub Caps	
XXX-4075	100 ft. lbs.
340-4975	50-60 ft. lbs.
340-4976	50-60 ft. lbs.
640-0003	50-60 ft. lbs.

Hub Cap Components		
359-6032	#8 Torx Screw	25 in. lbs. Maximum
359-5984	3/8 Mag Plug	5-9 ft. lbs. Maximum
359-5985	3/8 Pipe Plug	5-9 ft. lbs. Maximum

Hub Cap Mounting Bolts			
3/16	8-10 ft. lbs.	1/2	20-24 ft. lbs.
1/4	8-12 ft. lbs.	3/4	24-28 ft. lbs.
5/16	12-16 ft. lbs.	7/8	26-30 ft. lbs.
3/8	16-20 ft. lbs.	6 MM	8-12 ft. lbs.
7/16	18-22 ft. lbs.	8.5 MM	12-16 ft. lbs.

Hub Cap Specifications

Sentinel® Hub Caps



STEMCO Base Part No.	Oil Cap	Grease Cap	Bolt Circle	Bolt Size	No. of Bolts	Gasket Number	Oil Window Kit	Grease Window Kit
4009	348-4009	349-4009	5-1/2	5/16	6	330-3009	359-6112	359-6120
4013	348-4013	349-4013	5-1/2	5/16	5	330-3013	359-6112	359-6120
4046	348-4046	349-4046	5-1/2	5/16	6	330-3009	359-6112	359-6120
4075	348-4075	349-4075	6-1/4 x 8 UN(M)			330-3077	359-6112	359-6120
4095	348-4095	349-4095	5-1/2	5/16	6	330-3009	359-6112	359-6120
4195	348-4195	349-4195	6-3/4	5/16	6	330-3118	359-6112	359-6120
4281	348-4281	N/A	5-17/32	3/8	6	330-3122	359-6112	359-6120

Window kit consists of window, gasket, window ring assembly/gasket and Sentinel Cap Cover P/N 359-6103.

Integrated Sentinel® Hub Cap



STEMCO Base Part No.	Oil Cap	Grease Cap	Bolt Circle	Bolt Size	No. of Bolts	Gasket Number	Oil Window Kit	Grease Window Kit
4009	356-4009	358-4009	5-1/2	5/16	6	330-3009	359-6145	359-6146
4013	356-4013	358-4013	5-1/2	5/16	5	330-3013	359-6145	359-6146
4024	356-4024	358-4024	4-1/2	5/16	6	330-3024	359-6143	359-6144
4046	356-4046	358-4046	5-1/2	5/16	6	330-3009	359-6145	359-6146
4075	356-4075	358-4075	6-1/4 x 8 UN(M)			330-3077	359-6145	359-6146
4095	356-4095	358-4095	5-1/2	5/16	6	330-3009	359-6145	359-6146
4150	356-4150	358-4150	4-1/2	5/16	5	330-3150	359-6143	359-6144
4195	356-4195	358-4195	6-3/4	5/16	6	330-3118	359-6145	359-6146

Sentinel® ESP (Extended Service Plug)



STEMCO BASE PART NO.	DESCRIPTION
359-6124	ESP Plug Blister Pack (2/pk)
359-6125	ESP Plugs (bulk pack of 50)

Sentinel® ESP Filtered Vent



STEMCO BASE PART NO.	DESCRIPTION
359-6137	Drive Axle Vent (3/8" adapter)

Hub Cap Specifications

Hub Caps with Sentinel® ESP Plug



350-4065

Sentinel® ESP P/N	Description	Bolt Circle	Bolt Size	No. of Bolts	Gasket P/N
350-4065*	4065 Cap, no side fill plug	3-5/8	5/16	4	330-3040
353-4065*	4065 Cap, with side fill plug	3-5/8	5/16	4	330-3040

* Cannot use standard 340 or 343-4065 cap with ESP™ Plug. The casting has been modified to accept the ESP™, therefore, the above part numbers must be ordered to use this application with the ESP™ Plug.

Bulk Pack Hub Caps with Sentinel® ESP Plug

Sentinel® ESP P/N	Description	Bolt Circle	Bolt Size	No. of Bolts	Gasket P/N
300-5009	4009 Cap, no side fill plug Bulk Pack (50/Box)	5-1/2	5/16	6	330-3009
303-5009	4009 Cap, with side fill plug Bulk Pack (50/Box)	5-1/2	5/16	6	330-3009

PSI Ready Hub Cap



Grease
Hub Cap
340 Series

STEMCO Base Part No.	Grease Cap	Oil Cap
4009	340-4350	343-4350
4075	340-4351	343-4351
4195	340-4352	343-4352
Window Kits	359-6131	359-6130



Oil
Hub Cap
343 Series

Window kit consists of window, gasket and PSI retainer ring/gasket.

Hubo Bracket for Sentinel® and PSI Hub Caps

STEMCO Part No.	STEMCO Base Part No.	PSI Hub Cap Part No. (Grease)	PSI Hub Cap Part No. (Oil)	Stud Size	Height
610-0084	4195	340-4352	343-4352	5/16	5
610-0085	4009	340-4350	343-4350	5/16	4
610-0090	4075	340-4351	343-4351	*	1-7/8

* Bracket mounts on top of window ring with four replacement screws included with bracket. Height is for bracket only.

Hub Cap Specifications

Stamped Steel Grease Hub Caps



340-5096



340-5097

Hub Cap Includes Gasket	Bolt Circle	Bolt Size	No. of Bolts	A Height	B Inside Depth	C Flange I.D.	D Flange O.D.	Gasket Number
340-5094	5-1/2	5/16	6	2-1/2	2-13/32	4-3/8	6-1/4	330-3009
340-5096 <input type="checkbox"/>	5-1/2	5/16	6	2-1/2	2-13/32	4-3/8	6-1/4	330-3009
340-5097	5-1/2	5/16	6	2-1/2	2-13/32	4-3/8	6-1/4	330-3009
340-0044 <input type="checkbox"/>	4-1/2	5/16	6	2	1-15/16	3-5/16	5-3/16	330-3024

With Dirt Exclusion vent

Painted black

Solid Grease Hub Cap/Duckbill Vented

STEMCO Part No.	Bolt Circle	Bolt Size	No. of Bolts	Gasket Number
352-4009	5-1/2	5/16	6	330-3009
352-4195	6-3/4	5/16	6	330-3118



Dirt Exclusion Grease Hub Caps



Hub Cap Includes Gasket	Bolt Circle	Bolt Size	No. of Bolts	A Height	B Inside Depth	C Flange I.D.	D Flange O.D.	Gasket Number	* Window Kit
342-4009	5-1/2	5/16	6	2-11/16	1-15/16	4-3/8	6-1/4	330-3009	359-6095
342-4013	5-1/2	5/16	5	2-11/16	1-15/16	4-3/8	6-1/4	330-3013	359-6095
342-4024	4-1/2	5/16	6	2-5/8	1-7/8	3-1/2	5-1/4	330-3024	359-6094
342-4075	6-1/4 x 8 UN(M)			2-5/16	1-9/16	5-3/4	6-7/8	330-3077	359-6095
342-4095	5-1/2	5/16	6	1-13/16	1-1/6	4-9/16	6-3/16	330-3009	359-6095
342-4195	6-3/4	5/16	6	3-11/16	2-15/16	5-7/16	7-1/2	330-3118	359-6095
342-4249	5-1/2	5/16	6	1-13/16	1-11/16	4-7/16	6-3/16	330-3122	359-6096

* Window Kit consists of window, gasket and window ring gasket.

Hub Cap Specifications

Typical 4-3/8" Window Component Parts

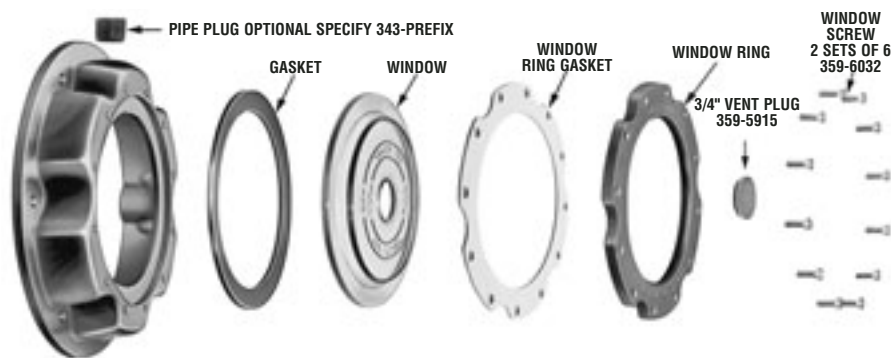

Typical 2-3/4" & 3-1/2" Window Component Parts

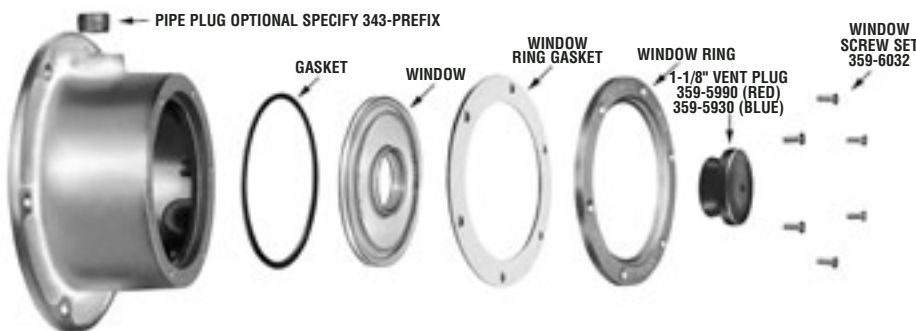

Standard Hub Cap Replacement Components

Window Diameter	Window	Gasket	Window Ring	Window Ring Gasket	Vent Plug	Screw Set 6/Set	Window Kit ☐	3/8 Pipe Plug ☒
2-3/4"	359-5983	359-5996	359-5997 ☐	359-3136	359-5990 ☐	359-6032	359-5999	359-5985
3-1/2"	359-5994	359-5991	359-5992	359-3127	359-5990 ☐	359-6032	359-5995	359-5985
3-1/2"	359-5981 ☐	359-5991	359-5992	359-3127	None	359-6032	359-6117	359-5985
4-3/8"	359-5918	359-5968	359-5970	359-3137	359-5915	359-6032 ☐	359-5912	359-5985
3-1/2"	359-6049 ☐	359-5991	359-5992	359-3127	359-5915	359-6032	359-6100 ☐	359-5985

☐ Window kit consists of window, gasket, window ring gasket and vent plug.

☒ Magnetic pipe plug part number 359-5984.

☐ 5 hole window ring.

☐ Blue vent plug part number 359-5930.

☐ Window for mounting Argo, STEMCO, and Veeder-Root hubodometers (17/32" dia. hole). Be sure hub cap has pipe plug filler before mounting.

☐ Window with recessed vent plug.

☐ Two sets required.

Dirt Exclusion Grease Hub Cap Replacement Components

Window Diameter	Window	Gasket	Window Ring	Window Ring Gasket	Screw Set 6/Set	Window Kit
2-3/4"	359-6086	359-5996	359-5997	359-3136	359-6032	359-6094
3-1/2"	359-6087	359-5991	359-5992	359-3127	359-6032	359-6095
4-3/8"	359-6088	359-5968	359-5970	359-3137	359-6032 ☐	359-6096

☐ Two sets required.

Sentinel® Hub Cap Replacement Components

Window Diameter	Window Kit ☐	Gasket	Window Ring Gasket	Screw Set 6/Set	Magnetic Pipe Plug
3-1/2"	359-6112 ☐	359-5991	359-3127	359-6032	359-5984
3-1/2"	359-6120 ☐☐	359-5991	359-3127	359-6032	359-5984

☐ Window kit consists of window, gasket, window ring with gasket and Sentinel® red cap cover part number 359-6103.

☐ Window kit for oil application.

☐☐ Window kit for grease application.

Hub Cap Specifications

Blank Hub Caps

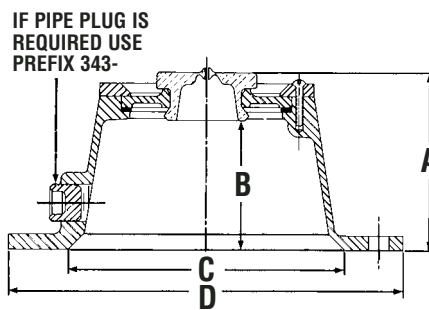

Hub Cap Includes Gasket	Bolt Circle	Bolt Size	No. of Bolts	A Height	B Inside Depth	C Flange I.D.	D Flange O.D.	Gasket Number
340-4054	None	Blank	None	2-1/8	1-3/8	4-1/32	8-5/8	330-3017

4009 Hub Cap Variations

Application	Part Number	Description
Oil	343-4350	Cast aluminum hub cap with PSI face & side fill plug
Oil	347-4009	Cast aluminum hub cap with hubo window & side fill plug
Oil	348-4009	Cast aluminum hub cap with Sentinel® Technology and side fill plug
Oil	356-4009	Integrated Sentinel®
Grease/Oil	340-4009	Cast aluminum hub cap with large red fill plug & no side fill plug
Grease/Oil	343-4009	Cast aluminum hub cap with large red fill plug & side fill plug
Grease/Oil	300-4009	Cast aluminum hub cap with large red fill plug & no side fill plug in 50 unit bulk pack
Grease/Oil	303-4009	Cast aluminum hub cap with large red fill plug & side fill plug in 50 unit bulk pack
Grease	340-4350	Cast aluminum hub cap with PSI face & no side fill plug
Grease	340-5096	Stamped steel hub cap with vent
Grease	340-5097	Stamped steel hub cap with no vent
Grease	342-4009	Cast aluminum hub cap with dirt exclusion window & no side fill plug
Grease	347-4278	Cast aluminum hub cap with hubo window & no side fill plug
Grease	347-5096	Stamped steel hub cap with hubo mounting hole & vent
Grease	349-4009	Cast aluminum hub cap with Sentinel® Technology and no side fill plug
Grease	352-4009	Cast aluminum hub cap with solid top (duckbill vent) & no side fill plug
Grease	358-4009	Integrated Sentinel®

Bulk Hub Caps

STEMCO Part No.	Standard Part No.	Bulk Qty.	Gasket Number
300-4009	340-4009	50	330-3009-Included
303-4009	343-4009	50	330-3009-Included
300-5097	340-4009	25	330-3009-Included

Hub Cap Specifications

4075 Hub Cap Variations



340-4075



570-7008



340-4975

Application	Part Number	Description
Oil	340-4975	Clear polycarbonate hub cap
Oil	343-4075	Cast aluminum hub cap with side fill plug
Oil	343-4351	Cast aluminum hub cap with PSI face & side fill plug
Oil	347-4075	Cast aluminum hub cap with hubo window and side fill plug
Oil	348-4075	Cast aluminum hub cap with Sentinel® Technology & side fill plug
Oil	353-4075	Cast aluminum hub cap with Sentinel® ESP plug & side fill plug
Oil	356-4075	Integrated Sentinel®
Grease/Oil	340-4075	Cast aluminum hub cap & no side fill plug
Grease	342-4075	Cast aluminum hub cap with dirt exclusion window
Grease	340-4320	Solid cast aluminum hub cap & no side fill plug
Grease	340-4351	Cast aluminum hub cap with PSI face & no side fill plug
Grease	340-4976	Clear polycarbonate hub cap with solid face—no vent
Grease	347-4343	Cast aluminum hub cap with hubo window and no side fill plug
Grease	349-4075	Cast aluminum hub cap with Sentinel® Technology & no side fill plug
Grease	350-4075	Cast aluminum hub cap with Sentinel® ESP & no side fill plug
Grease	358-4075	Integrated Sentinel®

Screw-on Caps must have O-rings (**330-3077**).

Use **570-7008** tool to tighten pro-par hub caps.

Hubodometer® Hub Caps



640-0001



640-0003

Hub Cap Includes Gasket	Gasket Part No.	Bolt Circle Diameter	Number Of Holes	Bolt Diameter	Aluminum Equivalent
640-0001*	641-0005	5-1/2	6	5/16	347-4009
640-0002*	641-0017	5-1/2	5	5/16	347-4013
640-0003*	330-3077		6-1/4 x 8 UN(M)		347-4075

* Vented.

Hub Cap Specifications

Popular Hub Cap Options

	<i>Standard Hub Cap No Side Fill</i>	<i>Dirt Exclusion Grease</i>	<i>Standard Hub Cap Side Fill</i>	<i>Standard Hub Cap Hubo Window</i>	<i>Sentinel® Hub Cap Oil</i>	<i>Sentinel® Hub Cap Grease</i>	<i>Solid Aluminum Grease/Vented</i>	<i>Integrated Sentinel® Oil</i>	<i>Integrated Sentinel® Grease</i>
	340	342	343	347	348	349	352	356	358
4009	X	X	X	X	X	X	X	X	X
4013	X	X	X	X	X	X		X	X
4024	X	X	X					X	X
4046	X		X		X	X		X	X
4075	X	X	X	X	X	X		X	X
4095	X	X	X		X	X	X	X	X
4195	X	X	X	X	X	X	X	X	X
4249	X	X	X						
4281					X	X			

Hub Cap Crossover

Competitive Part No.	Competitor's Name	STEMCO Part No.	Competitive Part No.	Competitor's Name	STEMCO Part No.	Competitive Part No.	Competitor's Name	STEMCO Part No.
1282	C/R	340-4975	401911P	Mechanex/Barrier	340-4975	DG-6PS	Dual Dynamics	343-4009
1612	C/R	343-4024	506085	Eaton	343-4024	DG-6PSC	Dual Dynamics	340-4046
1623	C/R	343-4066	506089	Eaton	343-4249	DG-7.5P	Dual Dynamics	340-4195
1627	C/R	343-4019	64002	TriSeal	343-4019	DG-7.5PS	Dual Dynamics	343-4195
1642	C/R	343-4013	64009	TriSeal	343-4009	DG-P	Dual Dynamics	340-4075
1643	C/R	343-4249	64009H	TriSeal	347-4009	DG-PS	Dual Dynamics	343-4075
1665	C/R	343-4042	64013	TriSeal	343-4013	DG-PSC	Dual Dynamics	343-4249
1681	C/R	343-4186	64024	TriSeal	343-4024	H075	National	343-4075
1682	C/R	343-4075	64029	TriSeal	343-4186	HS1643	Mechanex/Barrier	343-4249
1696	C/R	343-4195	64034	TriSeal	343-4034	HU009A	National	343-4009
1703	C/R	343-4249	64042	TriSeal	343-4042	HU009A	National	343-4046
1711	C/R	343-4024	64046	TriSeal	343-4046	HU013A	National	343-4013
1723	C/R	343-4066	64046	TriSeal	343-4095	HU019A	National	343-4019
1727	C/R	343-4019	64046	TriSeal	343-4249	HU024A	National	343-4024
1742	C/R	343-4013	64066	TriSeal	343-4066	HU028A	National	343-4186
1743	C/R	343-4009	64075A	TriSeal	343-4075	HU034A	National	343-4034
1743	C/R	343-4046	64075G	TriSeal	342-4075	HU042A	National	343-4042
1743	C/R	343-4095	64075P	TriSeal	340-4975	HU066A	National	343-4066
1753	C/R	343-4249	64249	TriSeal	343-4249	HU110A	National	343-4095
1765	C/R	343-4042	812928	Eaton	343-4095	HU110A	National	343-4249
1770	C/R	343-4034	815214	Eaton	343-4195	P411601	Mechanex/Barrier	343-4009
1781	C/R	343-4186	821338	Eaton	343-4009	P411605	Mechanex/Barrier	343-4095
1788	C/R	343-4249	821907	Eaton	343-4009	P411605	Mechanex/Barrier	343-4249
1800	C/R	347-4009	DG-5/6P	Dual Dynamics	340-4013	P411608	Mechanex/Barrier	343-4013
1801	C/R	347-4013	DG-5/6PS	Dual Dynamics	343-4013	P411620	Mechanex/Barrier	343-4066
1811	C/R	343-4024	DG-6F	Dual Dynamics	340-4046	P411622	Mechanex/Barrier	343-4042
1823	C/R	343-4042	DG-6F4.5	Dual Dynamics	340-4024	P411629	Mechanex/Barrier	343-4186
1842	C/R	343-4013	DG-6F4.5P	Dual Dynamics	343-4013	P411630	Mechanex/Barrier	343-4024
1843	C/R	343-4009	DG-6F4.5PC	Dual Dynamics	343-4024	P411640	Mechanex/Barrier	343-4034
1843	C/R	343-4046	DG-6F4.5S	Dual Dynamics	347-4075	P411655	Mechanex/Barrier	343-4075
1843	C/R	343-4095	DG-6FL	Dual Dynamics	340-4249	P411688	Mechanex/Barrier	343-4095
1865	C/R	343-4066	DG-6FP	Dual Dynamics	347-4009	P411967	Mechanex/Barrier	343-4046
1870	C/R	343-4034	DG-6FPC	Dual Dynamics	340-4024			
1890	C/R	343-4249	DG-6P	Dual Dynamics	340-4009			