

# Guardian® HP

Hub Seals



## **Longer Life for the Longest Haul**

### **New Technology for a Higher Standard of Performance**

Introducing Guardian® HP, the newest seal technology to improve per mile performance and cost-per-mile profitability. Guardian® HP gives you all the features of STEMCO's exclusive Guardian® seal design with the added benefits of our all-new High Performance sealing element. Guardian® HP's new technologically advanced seal has been developed for extra protection and greater sealing with its high performance sealing lip, superior contamination exclusion and self-lubricating thrust pad.

With new Guardian® HP, you're assured of longer life and easier installation. Installation right on the axle instead of the hub bore assures positive alignment every time with virtually error-proof installation. There's no tool impact on the seal, causing damage or installation related failures. Guardian® HP is easy to remove and service. No more damaged bearings during seal removal.



*A Higher Standard of Performance.™*

## Guardian® HP Application and Reference Guide

APPLICATION	GUARDIAN® HP	INNER BEARING	UNIVERSAL AXLE TOOL HEADS
19,000# Trailer Axle Standard Forge, Dana, Meritor, Eaton	307-0713	663	555-5100
Pro-Par Trailer Axle, Fruehauf, Eaton P-22, Meritor TP, Dana	307-0723	HM518445	555-5023
22,500# Trailer Axle, Meritor, Standard Forge, Dana, Eaton	307-0743	HM218248	555-5039
12,000# Front Axle, Meritor, Eaton, Ford, Freightliner, Kenworth, Western Star, Navistar, Peterbilt, Volvo GM	308-0836	39581 HM212044 HM212049,-X HM212047	555-5062 555-5061 555-5098 555-5066
16,000# Front Axle, Ford, Navistar, Mack, Meritor, White, Kenworth, Volvo GM, Western Star, Peterbilt	308-0864	6461A	555-5007
34,000# Drive Axle, Mack	309-0903	580 582	555-5072
44,000# Drive Axle, Mack	309-0904	663 HM516449,-C HM516449A	555-5072 555-5073
38,000#, 46,000# Tandem Axles, Eaton, Ford, Freightliner, Kenworth, Western Star, Peterbilt, Meritor, Navistar, Volvo GM	309-0973	594,-A 598,-A	555-5076 555-5071

## Guardian® HP Seal

Sealing lip, O.D. beads, self-lubricating thrust pad, and flexible contaminant exclusion lip all molded as a single unit from high performance HNBR-Teflon elastomer for fewer leak paths and better heat resistance.

Three O.D. beads for easier hub docking

Self-lubricating Thrust Pad

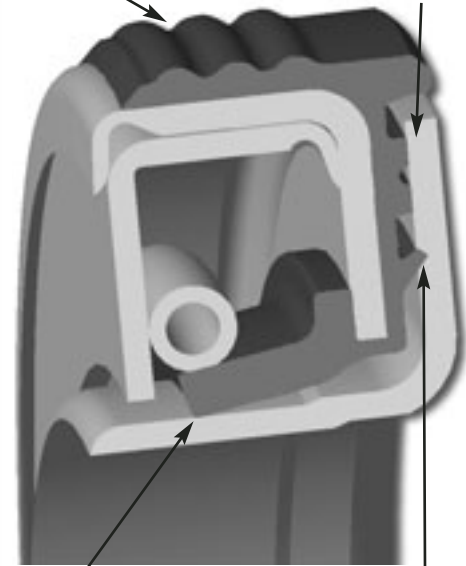

High performance sealing lip

Flexible contaminant exclusion lip

## Guardian® HP Interchange

GUARDIAN® HP	STEMCO	CR	CR PLUS	CR LONGLIFE	NATIONAL	5 STAR	OUTRUNNER
307-0713	372-7098	40136	40133	40146	370036A	380036A	850
307-0723	372-7099	42623	42623	42631	370065A	380065A	851
307-0743	372-7097	46305	46304	46308	370025A	380025A	859
308-0836	382-8036	35066	35059	35102	370001A	380001A	847
308-0864	382-8064	43764	43763	N/A	370048A	380048A	863
309-0903	392-9094	45099	45097	45108	370022A	380022A	856
309-0904	392-9112 392-9130	42672	42671	N/A	370031A	380031A	852
309-0973	392-9098	47697	47695	47693	370003A	380003A	861

Watch for announcement of additional applications when available.



*A Higher Standard of Performance.™*

STEMCO & Guardian HP are trademarks of STEMCO LLC  
©2002 STEMCO LLC

### STEMCO - USA

P.O. Box 1989 • Longview, TX 75606-1989  
(903) 758-9981 • 1-800-527-8492 • FAX: 1-800-874-4297  
[www.stemco.com](http://www.stemco.com)

### STEMCO - Canada

5900 Ambler Drive, Units 4 & 5 • Mississauga, ON L4W 2N3  
(905) 206-9922 • 877-232-9111 • FAX: 877-244-4555

Printed in the USA  
Part No. 571-2975  
Hudson 10-298 • 9/01

# Voyager®

**HUB-INSTALLED - UNITIZED DESIGN**



**Revolutionary  
Hub-Installed  
Unitized Seal  
that will Minimize  
Your Maintenance  
Costs.**



*A Higher Standard of Performance.™*

➤ **Easier and Faster Installations.** The Voyager® seal features a bonded rubber OD and piloted entry ensuring an easy and square installation. The ribbed rubber OD also forms a superior seal between the seal case and the hub bore.

➤ **Reduce Premature Failures and Rework.** The Voyager® seal utilizes a 4-zone labyrinth contaminant exclusion system. This technology is incorporated into a fully-unitized hub-installed seal.

➤ **Avoid Seal Damage Upon Installation.** The Voyager® seal's double steel case construction allows positive hub installation without warping or bending the seal.

➤ **Increase Reliability through Superior Material and Design.** The temperature-resistant nitrile polymer with hydrodynamic "pumping" features keeps the lubricant where it is intended to be.

➤ **Eliminate "Pry-Bar" Removal and Adjacent Component Damage.** The Voyager® seal's bonded rubber ID and OD allow for easier removal, yet STEMCO's patented anti-rotation "SMART" features lock the ID surface in place.

## Voyager® Cross Reference Guide

APPLICATION	VOYAGER® P/N	INNER BEARING	HUB TOOL P/N	BEARING GUIDE
19,000# Trailer Axle, Standard Forge, Dana, Meritor, Eaton	*373-0113	663	551-5313	570-0023
Pro-Par Trailer Axle, Fruehauf, Eaton P-22, Meritor TP, Dana	*373-0123	HM518445	551-5401	570-0025
22,500# Trailer Axle, Meritor, Standard Forge, Dana, Eaton	*373-0143	HM218248	551-5412	570-0026
Meritor Front Transit	*383-0101	6386 or 6379	551-5420	570-0020
12,000# Front Axle, Meritor, Eaton, Ford, Freightliner, Kenworth, Western Star, Navistar, Peterbilt, Volvo GM	*383-0136	39581 HM212044 HM212049,-X HM212047	551-5346 551-5346 551-5346 551-5346	570-0017 570-0018 570-0020 570-0019
12,000# Mack Front Axle	**383-0139	641 or HM212049	551-5413	570-0020
Navistar Front Axle, FA309, FA329	*383-0153	641 or HM212049 H715345	551-5419 551-5419	570-0020 570-0021
9,000# Front Axle, Navistar, FA 109 Cast Wheel '79 and up	*383-0156	641	551-5344	570-0020
16,000# Front Axle, Ford, Navistar, Mack, Meritor, White, Kenworth, Western Star, Peterbilt, Volvo GM	*383-0164	6461A	551-5327	570-0022
6,000#, 7,500#, Front Axle, Navistar	*383-0166	JM207049 or JM205149	551-5423	570-0035
GMC F-120 1985 and up	*383-0171	HM212047	551-5403	570-0019
8,000# Front Axle, GMC Topkick	*383-0175	JM205149	551-5417	570-0033
11,000# Front Axle, GMC Topkick	*383-0176	33212	551-5418	570-0031
34,000#, 38,000# Drive Axle, Mack	*393-0103	580 or 582	551-5415	570-0023
44,000# Drive Axle, Mack	*393-0104	663 or HM516449,-A	551-5414	570-0023
34,000# Drive Axle, Eaton, Ford, Navistar, White	*393-0112	47685 or 47686 47678 or 5760	551-5416 551-5416	570-0023 570-0022
Meritor Drive Transit	*393-0134	6580 or 6559	551-5421 551-5421	570-0025 570-0023
50,000#, 60,000# Drive Axle, Mack	*393-0148	687 or 780	551-5400	570-0032
38,000#, 46,000# Tandem Axles, Eaton, Ford, Freightliner, Kenworth, Western Star, Peterbilt, Meritor, Navistar, Volvo GM	*393-0173	594 or 594A 598 or 598A	551-5320 551-5320	570-0028 570-0027

\*Currently available. \*\* Also sold as 383-8139 Kit, which includes the 310-1132 shoulder bushing.

## Voyager® Seal

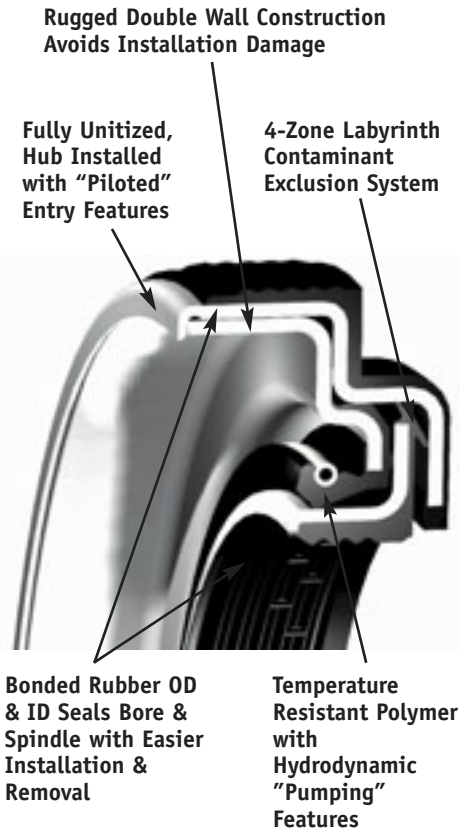

## Voyager® Interchange

VOYAGER®	CR	CR PLUS	NATIONAL	5 STAR	OUTRUNNER
373-0113	40136	40133	370036A	380036A	850
373-0123	42623	42622	370065A	380065A	851
373-0143	46305	46304	370025A	380025A	859
383-0101	40086	40088	370066A	N/A	N/A
383-0136	35066	35059	370001A	380001A	847
383-0139	39988	39977	370033A	N/A	N/A
383-0153	44922	44919	370124A	N/A	855
383-0156	45103	45102	370131A	380131A	857
383-0164	43764	43763	370048A	380048A	863
383-0166	28758	N/A	370150A	N/A	N/A
383-0171	36358	36357	370011A	N/A	N/A
383-0175	N/A	N/A	370199A	N/A	N/A
383-0176	N/A	N/A	370211A	N/A	N/A
393-0103	45099	45097	370022A	380022A	856
393-0104	42672	42671	370031A	380031A	852
393-0112	38780	38779	370023A	380023A	849
393-0134	48690	N/A	370195A	N/A	N/A
393-0148	52658	N/A	370069A	380069A	N/A
393-0173	47697	47695	370003A	380003A	861



A Higher Standard of Performance.™

QS 9000 & ISO 9001

STEMCO and Voyager are registered trademarks of STEMCO LLC  
©2002 STEMCO LLC

### STEMCO - USA

P.O. Box 1989 • Longview, TX 75606-1989  
(903) 758-9981 • 1-800-527-8492 • FAX: 1-800-874-4297  
[www.stemco.com](http://www.stemco.com)

### STEMCO - Canada

5900 Ambler Drive, Units 4 & 5 • Mississauga, ON L4W 2N3  
(905) 206-9922 • 877-232-9111 • FAX: 877-244-4555



Printed in the USA  
Part No. 571-2998  
Hudson 10-330 • 5/02

## Discover

**HUB-INSTALLED - UNITIZED DESIGN**



**Discover® Seals.  
Minimizing  
Costs by  
Exceeding the  
Industry's Best.**



*A Higher Standard of Performance.™*

*As a pioneer in the hub seal industry, STEMCO proudly offers a technologically advanced high performance seal designed for long-life expectations.*

☉ **Increase the Performance Expectations of Wheel Ends.** The Discover® seal features a high temperature elastomeric co-polymer sealing element combined with Teflon®. The revolutionary design incorporates hydrodynamic "pumping" features to keep the lubricant where it is intended to be.

☉ **Maintain the Lubricant's Integrity to Lengthen the Life of the Seal.** The premium sealing element is protected by a four-zone labyrinth to provide unmatched contaminant exclusion and performance.

☉ **Have Complete Confidence During the Installation Stage.** The Discover® seal's piloted entry allows an easy and square installation every time. The double steel case is the impact point for the tool head to maintain the internal geometries.

☉ **Reduce Removal Time and Effort Without Special Tools or Adjacent Component Damage.** The Discover® seal consists of a bonded, ribbed rubber OD and ID for easier removals, yet STEMCO's patented "SMART" anti-rotation features insure positive positioning and locking of the seal to the spindle.

**Experience the difference! STEMCO Discover® Seals.  
High Performance. Revolutionary Design.**

## Discover® Cross Reference Guide

APPLICATION	DISCOVER® P/N	INNER BEARING	HUB TOOL P/N	BEARING GUIDE
19,000# Trailer Axle Standard Forge, Dana, Meritor, Eaton	373-0213	663	551-5313	570-0023
Pro-Par Trailer Axle, Fruehauf, Eaton P-22, Meritor TP, Dana	373-0223	HM518445	551-5401	570-0025
22,500# Trailer Axle, Meritor, Standard Forge, Dana, Eaton	373-0243	HM218248	551-5412	570-0026
12,000# Front Axle, Meritor, Eaton, Ford, Freightliner, Kenworth, Western Star, Navistar, Peterbilt, Volvo GM	383-0236	39581 HM212044 HM212049,-X HM212047	551-5346 551-5346 551-5346 551-5346	570-0017 570-0018 570-0020 570-0019
12,000# Mack Front Axle	*383-0239	641 or HM212049	551-5413	570-0020
16,000# Front Axle, Ford, Navistar, Mack, Meritor, White, Kenworth, Western Star, Peterbilt, Volvo GM	383-0264	6461A	551-5327	570-0022
34,000#, 38,000# Drive Axle, Mack	393-0203	580 or 582	551-5415	570-0023
44,000# Drive Axle, Mack	393-0204	663 or HM516449,-A	551-5414	570-0023
34,000# Drive Axle, Eaton, Ford, Navistar, Volvo GM	393-0212	47685 or 47686 47678 or 5760	551-5416 551-5416	570-0023 570-0022
38,000#, 46,000# Tandem Axles, Eaton, Ford, Freightliner, Kenworth, Western Star, Peterbilt, Meritor, Navistar, Volvo GM	393-0273	594 or 594A 598 or 598A	551-5320 551-5320	570-0028 570-0027

\*Also sold as 383-8239 Kit, which includes the 310-1132 shoulder bushing.

## Discover® Seal Design Features

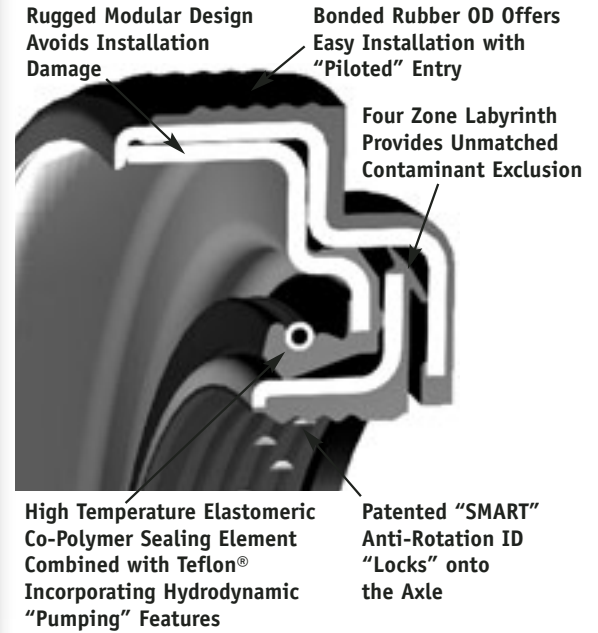

## Discover® Interchange

DISCOVER®	CR	CR PLUS	CR LONGLIFE	NATIONAL	5 STAR	OUTRUNNER
373-0213	40136	40133	40146	370036A	380036A	850
373-0223	42623	42622	42631	370065A	380065A	851
373-0243	46305	46304	46308	370025A	380025A	859
383-0236	35066	35059	35102	370001A	380001A	847
383-0239	39988	39977	39990	370033A	N/A	N/A
383-0264	43764	43763	N/A	370048A	380048A	863
393-0203	45099	45097	45108	370022A	380022A	856
393-0204	42672	42671	N/A	370031A	380031A	852
393-0212	38780	38779	38783	370023A	380023A	849
393-0273	47697	47695	47693	370003A	380003A	861

**STEMCO Discover® vs. competitor seals (listed by main sealing lip material). Hours shown are accelerated lab life test hours.**

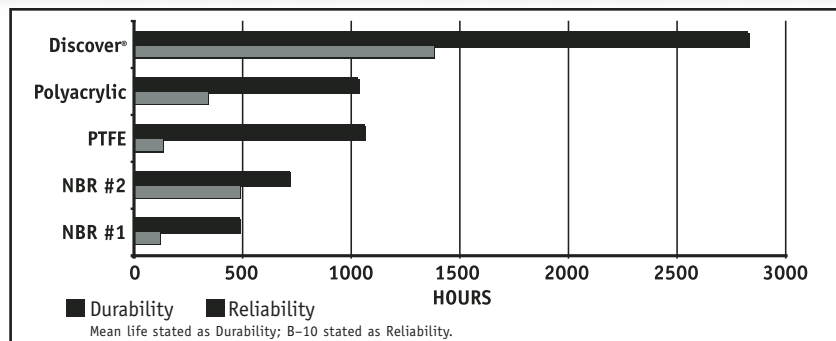

# STEMCO®

*A Higher Standard of Performance.™*

QS 9000 & ISO 9001

STEMCO and Discover are registered trademarks of STEMCO LLC  
©2002 STEMCO LLC

### STEMCO - USA

P.O. Box 1989 • Longview, TX 75606-1989  
(903) 758-9981 • 1-800-527-8492 • FAX: 1-800-874-4297  
[www.stemco.com](http://www.stemco.com)

### STEMCO - Canada

5900 Ambler Drive, Units 4 & 5 • Mississauga, ON L4W 2N3  
(905) 206-9922 • 877-232-9111 • FAX: 877-244-4555



Printed in the USA  
Part No. 571-3009  
Hudson 10-352 • 9/01

# GRITGUARD®

*Two-piece Hub Seal design for improved dirt exclusion*

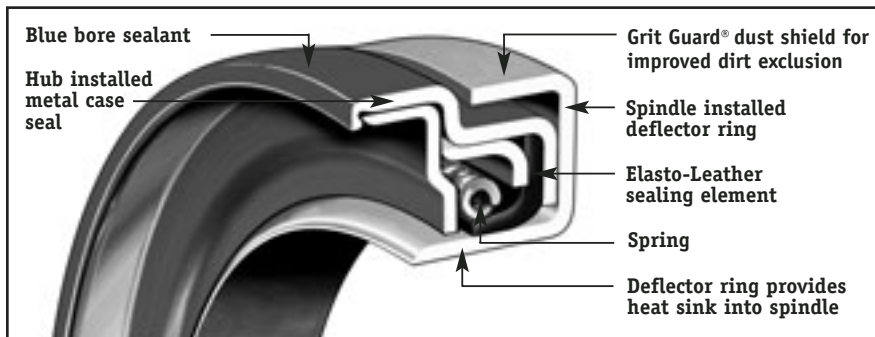

*Designed to reduce maintenance and prevent unnecessary wear on expensive spindles, the Grit Guard® two-piece design provides effective and lasting protection against contamination.*

## Features and Benefits

☉ A two-piece design, the Grit Guard® Seal features a spindle-installed deflector ring. This provides dirt exclusion for extended seal performance and insures a new surface for the sealing lip. The deflector ring can often repair a damaged or worn spindle shoulder.

☉ The hub-installed metal case seal provides a metal-to-metal continuous press fit between the seal and hub. In addition, a blue coating is applied to the seal to prevent minor seepage between the seal and hub.

☉ Grit Guard's® Elasto-Leather sealing lip provides an excellent temperature range from -65°F to +250°F remaining flexible and durable. Also, the lip rotates on the deflector ring for improved heat dissipation and less lip travel per wheel rotation.

☉ Grit Guard® is available for the rugged, severe duty applications that other seals are not available for.



*A Higher Standard of Performance.™*

## Grit Guard® Reference Guide

APPLICATION	GRIT GUARD® P/N	SEAL/RING	INNER BEARING	UNIVERSAL HEAD*	HUB TOOL**	BEARING GUIDE
20,000# Trailer Axle, Meritor, Shuler	372-7095	2118/1510	665A	555-5069	551-5321	570-0024
22,500# Trailer Axle, Dana, Eaton, Meritor, Standard Forge	372-7097	2110/1504	HM218248	555-5039	551-5412	570-0026
19,000# Trailer Axle, Dana, Eaton, Meritor, Standard Forge	372-7098	2109/1507	663	555-5100	551-5313	570-0023
Pro-Par Trailer Axle, Dana, Eaton P-22, Fruehauf, Meritor TP	372-7099	2023/1503	HM518445	555-5023	551-5401	570-0025
19,000# Drive Axle, Eaton, Ford, GMC, Navistar, White	392-9088	2113/1517	594 or 594A	555-5076	551-5412	570-0028
50,000# & 60,000# Drive Axle, Mack	392-9089	2097/1516	687 or 780	555-5004	551-5400	N/A
34,000# Drive Axle, Mack	392-9094	2129/1511	580 or 582	555-5072	551-5393	570-0023
38,000#, 40,000#, 42,000# Tandem Drive Axles, Eaton, Ford, GMC, Mack, Navistar, White	392-9096	2114/1508	595 598	555-5072 555-5071	551-5412 551-5412	570-0023 570-0027
34,000# Drive Axle, Eaton, Ford, Navistar, White	392-9099	2102/1501	47685 or 47686 47678 or 5760	555-5031 555-5074	551-5318 551-5318	570-0023 570-0022
44,000# Drive Axle, Mack	392-9112	2213/1515	663 or HM516449, -C	555-5072	551-5364	570-0023
44,000# Drive Axle, Mack	392-9130	2213/1519	HM516449A	555-5073	551-5364	570-0023
38,000#, 46,000# Tandem Axles, Eaton, Ford, Freightliner, Kenworth, Meritor, Navistar, Peterbilt, Volvo GM, Western Star	392-9131	2106/1525	594 or 594A 598 or 598A	555-5076 555-5071	551-5320 551-5320	570-0028 570-0027
38,000# Drive Axle, Eaton, GMC, Mack, Meritor	392-9132	2104/1018 2115/1530	598A 594A	555-5071 555-5076	551-5356 551-5356	570-0027 570-0028

\*Use Universal Body 555-0001 with 555 Series Tool Heads. \*\*Use Universal Fleet Tool Handle 551-0001 with 551 Series Tool Heads.

## Grit Guard® Interchange

GRIT GUARD®	CR	CR PLUS	MIDLAND	NATIONAL	OUTRUNNER	TRI SEAL
372-7095	43753	43752	749400	370037A	853	69599
372-7097	46305	46304	755400	370025A (38)	859	69598
372-7098	40136	40133	747400	370036A (38)	850	69597
372-7099	42623	42622	745400	370065A (38)	851	69596
392-9088	45160	45158	772400	370021A	307	69791
392-9089	52664	52658	791400	370069A	N/A	69781
392-9094	45099	45097	785400	370022A (38)	856	70796
392-9096	43860	43861	771400	370019A	854	69797
392-9099	38780	38779	774400	370023A (38)	849	69794
392-9112	42672	42671	789400	370031A (38)	852	69788
392-9130	42672	42671	789400	370031A (38)	852	69788
392-9131	47697	47695	781400	370003A (38)	861	69799
392-9132	47690	N/A	763400	370005A	308	69757

\*Refer to STEMCO Wheel End Products Catalog #572-0012 for complete applications and coverage listings.



*A Higher Standard of Performance.™*

QS 9000 & ISO 9001  
STEMCO and Grit Guard are registered trademarks of STEMCO LLC  
©2002 STEMCO LLC

**STEMCO - USA**  
P.O. Box 1989 • Longview, TX 75606-1989  
(903) 758-9981 • 1-800-527-8492 • FAX: 1-800-874-4297  
[www.stemco.com](http://www.stemco.com)

**STEMCO - Canada**  
5900 Ambler Drive, Units 4 & 5 • Mississauga, ON L4W 2N3  
(905) 206-9922 • 877-232-9111 • FAX: 877-244-4555



Printed in the USA  
Part No. 571-2896  
Hudson 10-317 • Rev. 5/02