

Haldex

Haldex
Life Seal® Actuators
Deliver Reliability,
Long Life and Value

L20438

Rev. 2/08



ACTUATORS



Haldex Life Seal® Actuators

Durability and Reliability Mile After Mile

Haldex is the leading supplier of double diaphragm and service brake actuators throughout the world. For more than 40 years, our innovations have set the industry standard for design, reliability and extended product life. We are committed to improving spring brake performance to completely eliminate hidden obstacles to performance and service life, especially the problems of premature spring fracture and chamber contamination. The Haldex Life Seal® actuator technology is the result of that commitment and raises the bar of YOUR expectations.

Isolated Chamber Prevents Spring Fracture

Compression spring fracture is the major cause of all spring brake failures. Water, salt, oil and other contaminants attack and weaken the spring causing corrosion and ultimately, failure. Since the Life Seal chamber is completely sealed, contaminants cannot reach the power spring. The spring housing does not contain vent holes, external breather tubes, cage

tool plugs or filters so the spring is isolated from the external environment. A special internal valve allows air to escape through the vehicle's air system instead of through the housing.

Life Seal Maximizes Output Force

Most new spring brakes meet a minimum required output force. The ability for that spring to maintain output force is lost over time. Through technological innovation,

Life Seal is the only actuator to maximize output force over an extended period. A unique patented power spring maintains high output force while increasing strength. The center tube guides the form-fit pressure plate, which stabilizes the spring coil through the full range of travel. This prevents contact with the spring housing and dramatically reduces coil clash.

Life Seal Lowers Your Cost of Ownership

A standard actuator usually performs adequately for one to three years, although



their complex warranties are often longer. Life Seal advanced technology offers the first Six-Year, unlimited mileage warranty coverage*. That means you can count on superior Life Seal performance and long life to lower your total cost of ownership over the period of service.

Haldex Has the Actuator You Need

Haldex offers a complete family of actuators designed and built to the same high standards. The Life Seal family includes a 2430 and 3030 in 2.5" and 3.0" stroke models. In the future, expect Haldex to continue innovative spring brake technology, performance, life and cost-effectiveness. A complete listing of our product line is included here.

*See Haldex Warranty Policy Number L20221 for details.

USE OF VEHICLE AIR SYSTEM

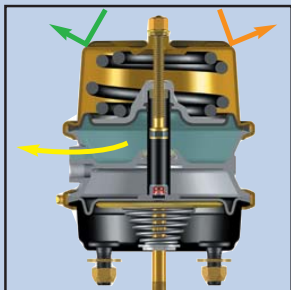

Parking Brake Application

Air is exhausted from the parking side. The integral caging tool and push rod maintain alignment as the main spring extends to apply the parking brake.

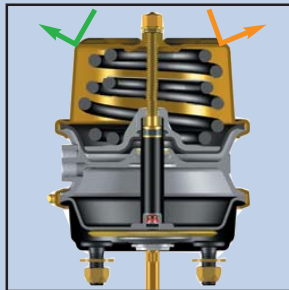

Parking Brake Applied

Vehicle parked. The spring chamber is totally sealed, contaminants are prevented from entering the spring chamber.

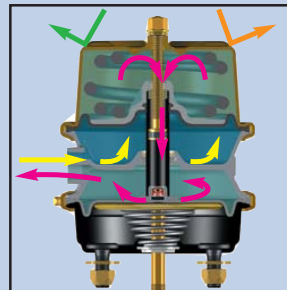

Parking Brake Retraction

Air enters the parking side, compressing the main power spring. Air in the spring chamber is exhausted down the push rod tube, through an internal valve, and out the vehicle air service side system.

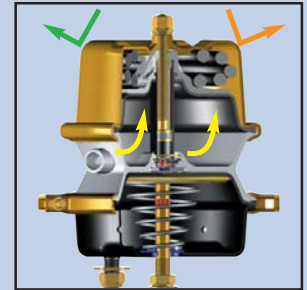

Parking Brake Retracted

Vehicle under normal operation. Completely sealed spring chamber prevents road contaminants like water, salt and dirt from attacking the spring.

LIFESEAL

ACTUATORS

TECHNOLOGY FOR PERFORMANCE AND RELIABILITY

ZINC-PLATED STEEL CHAMBER isolates the power spring preventing all contaminants from entering the spring chamber. No vent holes, no air filters, no caging tool plugs and no external breather tubes.

PUSH ROD HOUSING TUBE maintains coil alignment and reduces coil stress and coil clash by guiding the spring piston and power spring on a straight path.

INTERNAL VALVE allows trapped air inside the spring chamber during the caging process to escape through the vehicle air system.

PATENTED PILOTING DUST SHIELD is designed to enhance automatic brake adjuster operation by maintaining push rod alignment and reducing contaminants in the service chamber.

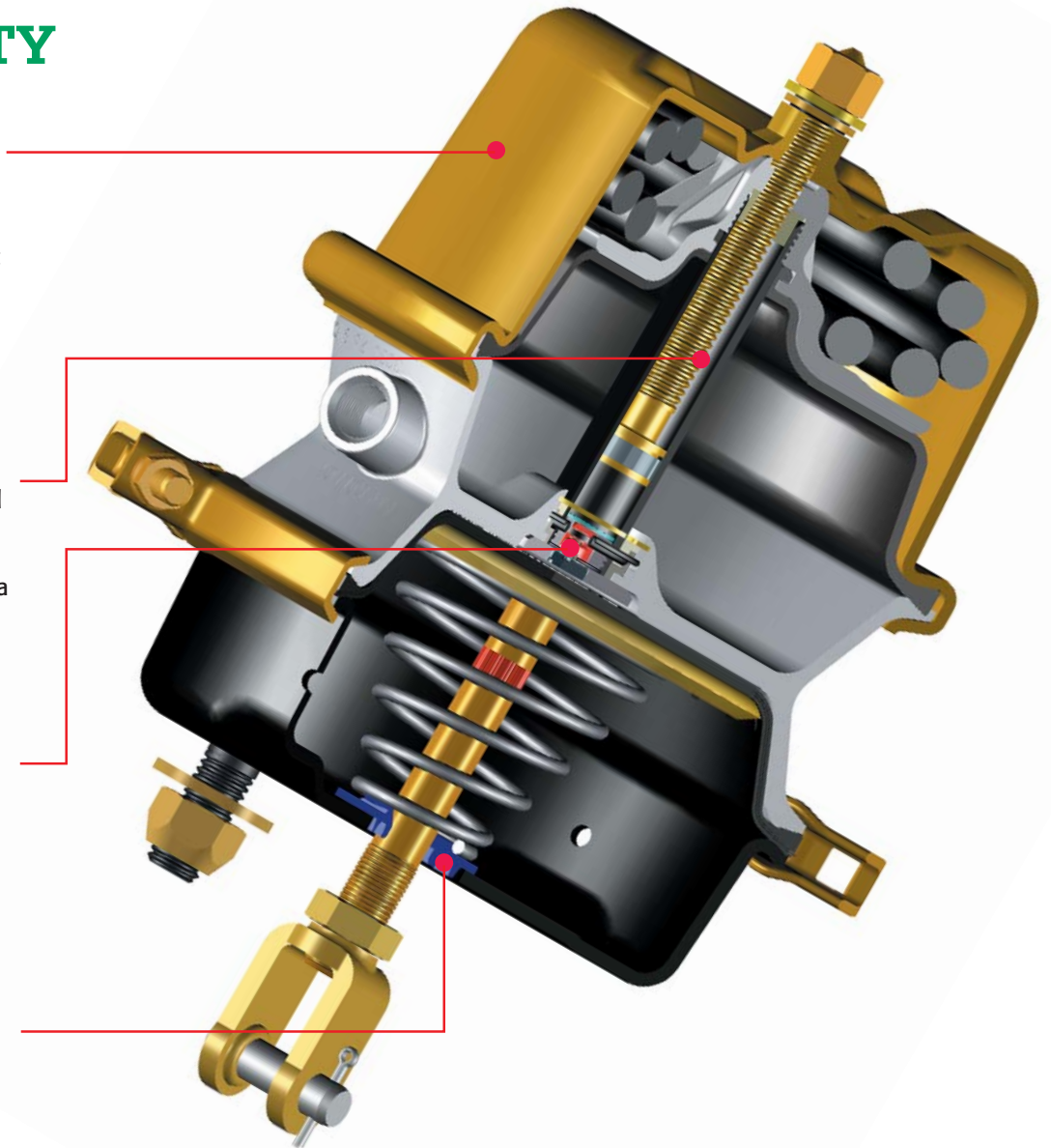

LIFESEAL

ACTUATORS

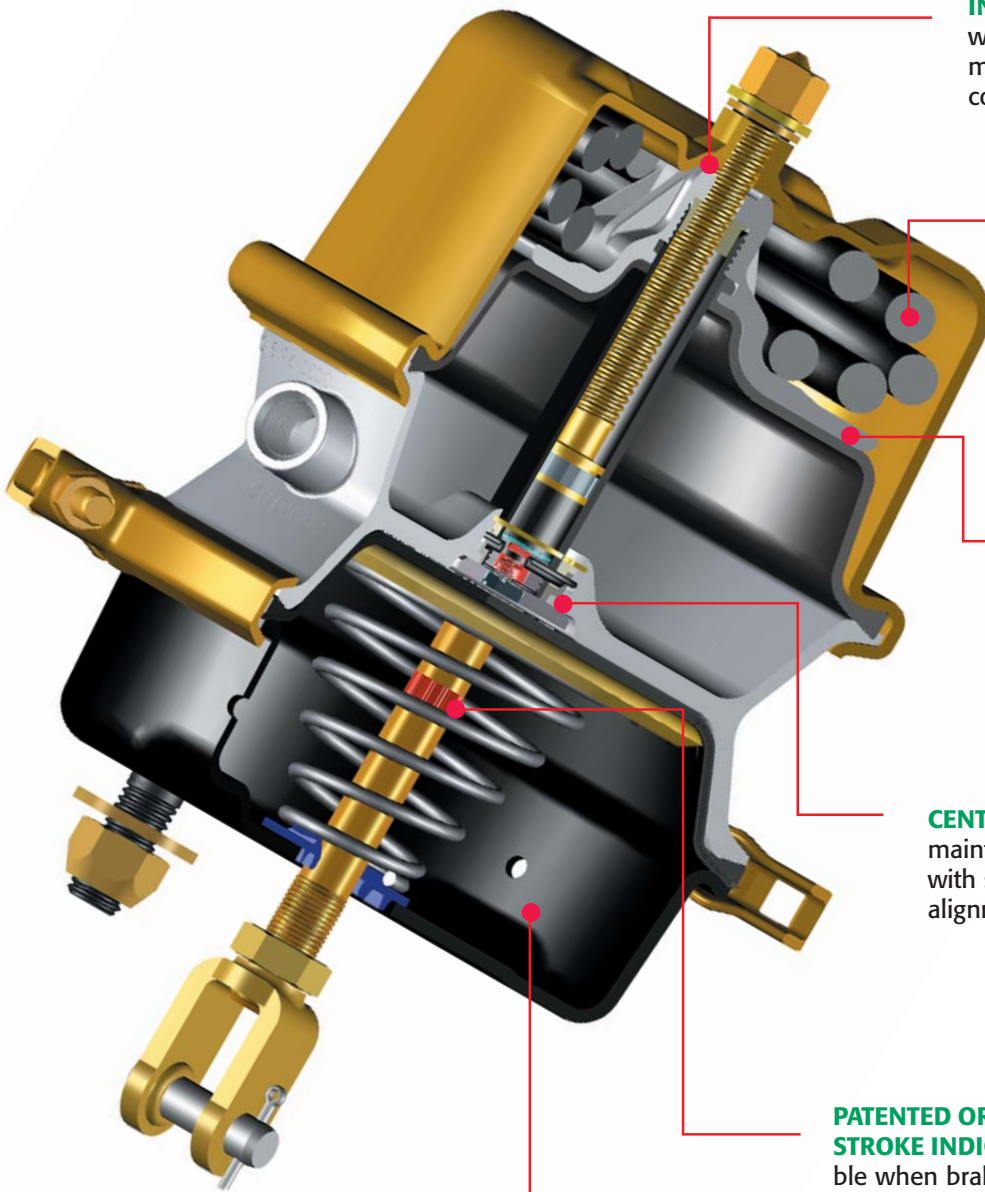

INTEGRAL CAGING TOOL with grade 8 ACME threads makes caging quick, convenient and easy.

SPECIAL HEAT-TREATED POWER SPRING, producing maximum output force and extended life, is powder-coated for extra protection.

PATENTED ALUMINUM FORM FIT SPRING PISTON reduces overall actuator length.

CENTER BODY SEAL maintains a positive seal with superior guiding and alignment.

PATENTED ORANGE ALERT STROKE INDICATOR is visible when brakes are out of adjustment.

EPOXY COATED 9-GAUGE STUD HOUSING for maximum strength.



Advantages of Long Stroke Actuators

When compared to a standard stroke, Haldex Long Stroke Actuator provides a higher and more constant force output.

As wear and heat take effect on the foundation brake system, the extra stroke and additional output force is required to maintain braking. The result is more available power to stop your vehicle.

Haldex Life Seal Piggyback Replacement Kit

After years of faithful service, it may become necessary to replace your Life Seal Actuator. Order the genuine Haldex Life Seal Piggyback Replacement Kit. The kit includes one each of the Life Seal Piggyback actuator, a premium Haldex service diaphragm and a new double clamp assembly. For ease of handling each kit is individually boxed.

Your replacement kit carries the same warranty as the original equipment, six-year unlimited mileage.

Contact the Haldex Technical Service Department at 800-643-2374 for additional details.



PART NUMBER: LP3030K

TO MINIMIZE SERVICE SIDE AIR LEAKS, HALDEX RECOMMENDS REPLACING BOTH THE SERVICE CLAMP AND SERVICE DIAPHRAGM DURING PIGGYBACK REPLACEMENT.

Haldex Actuator Product Offering

Life Seal - 4 available sizes

Gold Seal - 12 available sizes

Service Chamber - 11 available sizes

Clamp Style - 5 available sizes

Wedge Brake - 2 service chambers and 4 double diaphragm available sizes

Air Disc Service Chamber - 3 available sizes

Air Disc Double Diaphragm - 4 available sizes

Blue Seal - 3 available sizes for the European Market

Anchorlok and Maxibrake Products - including the R-Series, Camtite and Type 50 actuators

Haldex offers proprietary vehicle technology solutions to the global vehicle industry within specific niches. We focus on products to improve safety, the environment and vehicle dynamics.

We are enhancing our competitive capabilities and building long-term customer relationships through high performance, low total costs to the customer through the product's service life, ethical business practices and commitment to long-term partnerships. Haldex operations are divided into four business areas: Commercial Vehicle Systems, Hydraulic Systems, Garphyttan Wire and Traction Systems.

Austria

Haldex Wien Ges.m.b.H.
Vienna
Tel.: +43 1 8 65 16 40
Fax: +43 1 8 65 16 40 27
E-Mail: info.AT@haldex.com

Belgium

Haldex N.V./S.A.
Balegem (Ghent)
Tel.: +32 9 363 90 00
Fax: +32 9 363 90 09
E-Mail: info.BE@haldex.com

Brazil

Haldex do Brasil Ind. e Com, Ltda.
São Paulo
Tel.: +55 11 213 55 000
Fax: +55 11 503 49 515
E-Mail: info.BR@haldex.com

Canada

Haldex Ltd
Guelph, Ontario
Tel.: +1 519 826 7723
Fax: +1 519 826 9497
E-Mail: info.CA@haldex.com

China

Haldex International Trading Co. Ltd.
Shanghai
Tel.: +86 21 5240 0338
Fax: +86 21 5240 0177
E-Mail: info.CN@haldex.com

France

Haldex Europe SAS
Weyersheim (Strasbourg)
Tel.: +33 3 88 68 22 00
Fax: +33 3 88 68 22 09
E-Mail: info.EUR@haldex.com

Germany

Haldex Brake Products GmbH
Heidelberg
Tel.: +49 6221 7030
Fax: +49 6221 703400
E-Mail: info.DE@haldex.com

Hungary

Haldex Hungary Kft.
Szentlőrincváta
Tel.: +36 29 631 300
Fax: +36 29 631 301
E-Mail: info.HU@haldex.com

India

Haldex India Limited
Nasik
Tel.: +91 253 2380094
Fax: +91 253 2380729
E-Mail: info.IN@haldex.com

Italy

Haldex Italia SRL
Biassono (Milan)
Tel.: +39 039 471 702
Fax: +39 039 27 54 309
E-Mail: info.IT@haldex.com

Poland

Haldex Sp. z.o.o.
Praszka
Tel.: +48 34 350 11 00
Fax: +48 34 350 11 11
E-Mail: info.PL@haldex.com

Russia

OOO Haldex RUS
Moscow
Tel.: +7 495 747 59 56
Fax: +7 495 786 39 70
E-Mail: info.RU@haldex.com

South Korea

Haldex Korea Ltd.
Seoul
Tel.: +82 2 2636 7545
Fax: +82 2 2636 7548
E-Mail: info.KR@haldex.com

Spain

Haldex España S.A.
Parets del Valles (Barcelona)
Tel.: +34 93 573 10 30
Fax: +34 93 573 07 28
E-Mail: info.ES@haldex.com

Sweden

Haldex Brake Products AB
Landskrona
Tel.: +46 418 47 60 00
Fax: +46 418 47 60 01
E-Mail: info.SE@haldex.com

United Kingdom

Haldex Ltd.
Newton Aycliffe
Tel.: +44 1325 310 110
Fax: +44 1325 311 834
E-Mail: info.GBAy@haldex.com

Haldex Brake Products Ltd.

Redditch
Tel.: +44 1527 499 499
Fax: +44 1527 499 500
E-Mail: info.GBRe@haldex.com

USA

Haldex Brake Products Corp.
Kansas City, MO
Tel.: +1 816 891 2470
Fax: +1 816 891 9447
E-Mail: info.US@haldex.com

©2007, This material may contain Haldex trademarks and third party trademarks, trade names, corporate logos, graphics and emblems which are the property of their respective companies. The contents of this document may not be copied, distributed, adapted or displayed for commercial purposes or otherwise without prior written consent from Haldex.

