

**Haldex**

L30033  
11/01

# SERVICE MANUAL

## Truck and Trailer Applications



# AUTOMATIC BRAKE ADJUSTERS

---

**Innovative Vehicle  
Technology**

---

---

## Table of Contents

Operation .....	1
Brake Adjuster Part Number and Build Date .....	1
Steer Axle Applications.....	2
Drive Axle Applications.....	2
Trailer Axle Applications .....	3
Installation Procedures . . . . .	4
Routine Visual/Operational Checks . . .	6
Service and Lubrication Intervals . . . .	6
Foundation Brake Operational Check and Troubleshooting . . . . .	7
Brake Adjuster Checking Procedures . .	9
Brake Adjuster Operational Check . . .	9
Typical Parts Identification and Location . . . . .	10
Torque Specifications.....	11
Frequently Asked Questions .....	12
Additional Parts and Service Information.....	13



### **Important Notice**

This symbol is used throughout this manual to call attention to procedures where carelessness or failure to follow specific instructions may result in personal injury and/or component damage.

The description and specifications contained in this service publication are current at the time of printing. Haldex Brake Products Corp. reserves the right to discontinue or modify its models and/or procedures and to change specifications at any time without notice.

## Operation

The Haldex automatic brake adjuster is a clearance sensing brake adjuster that maintains a nominal distance or clearance between lining and drum.

### When the Brake Applies:

Upon brake application, the brake adjuster rotates and moves the shoes into contact with the drum. The clearance notch corresponds to the normal lining-to-drum clearance. As the brake application continues, the rack moves upward and rotates the one-way clutch which slips in this direction. As the brake torque increases, the coil spring load is overcome and the wormshaft is displaced axially, releasing the cone clutch.

### When the Brake Releases:

When the brake begins its return stroke, the coil spring load returns to normal and the cone clutch is again engaged. The rack is pulled back to its original position in the notch, and any additional travel brought about by lining wear causes the rack to turn the locked one-way clutch and rotates the wormshaft through the locked cone clutch. The wormshaft then rotates the worm wheel and camshaft, adjusting the brakes.

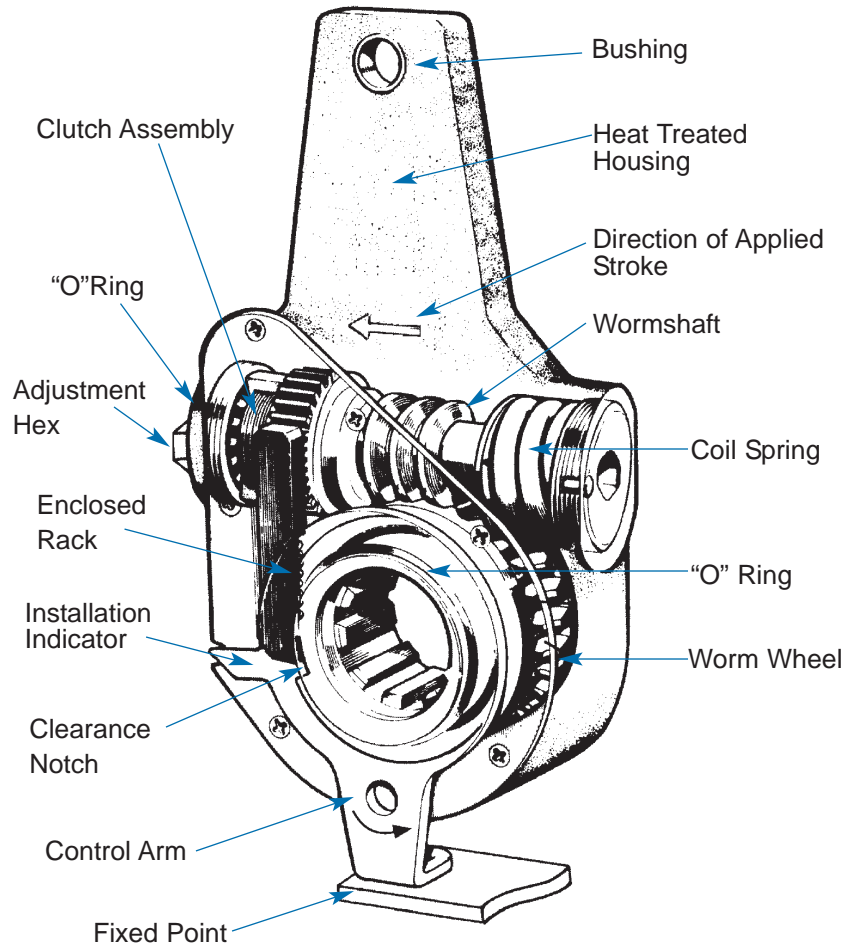

## Brake Adjuster Identification

### Part Number:

409 prefix = Reduced maintenance adjuster

429 prefix = No-Lube™ adjuster

### Serial Number:

First 3 digits = Day of year built

Last 2 digits = Year of build

### After Sept. 1989

The Part No. P/N40910224 would be our adjuster part number 409-10224.

Part Number  
P/N40910224  
Serial Number  
S/N33489

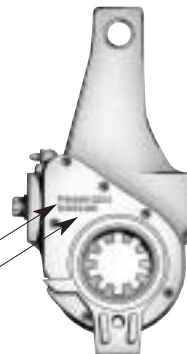

### Prior to Sept. 1989

The first three numbers stamped on the cover plate is the brake adjuster part number. For example: 224 would be our adjuster part number 409-10224.

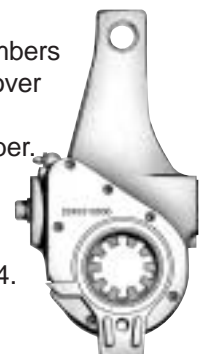

## Typical Applications

### Steer Axle

Figures 1–4 show typical brackets for automatic brake adjuster applications on steer axle brake assemblies. Refer to pages 4 and 5 for detailed installation procedures.

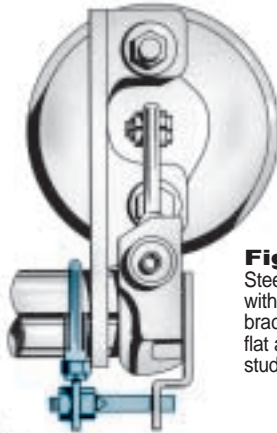

**Figure 1**  
Steer axle with clamp bracket and flat anchor stud

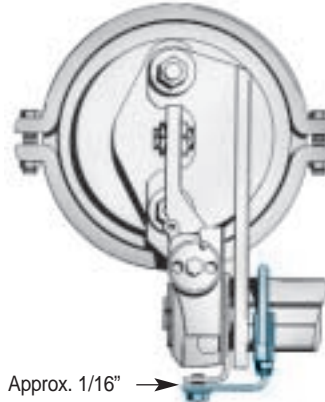

**Figure 2**  
Steer axle with clamp bracket and round anchor stud

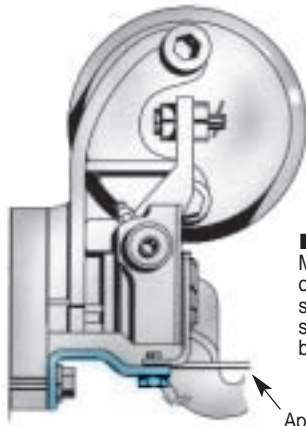

**Figure 3**  
Mack 16,000# or higher rated steer axles with spider mounted bracket

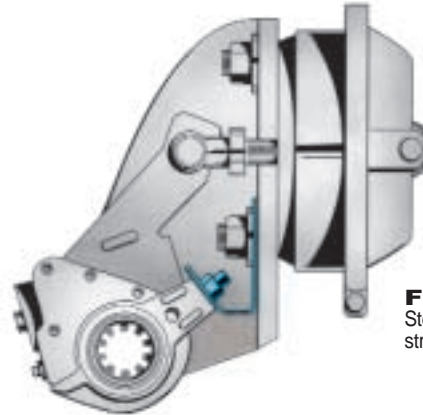

**Figure 4**  
Steer axle with strap bracket

### Drive Axle

Figures 5–8 show typical brackets for automatic brake adjuster applications on drive axle brake assemblies. Refer to pages 4 and 5 for detailed installation procedures.

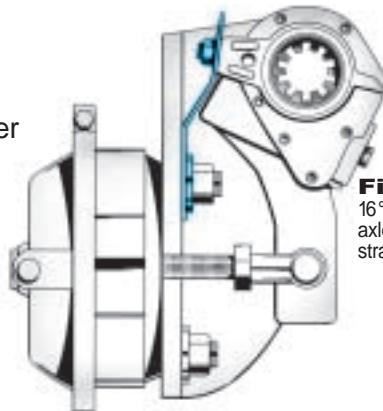

**Figure 5**  
16° drive axle with strap bracket

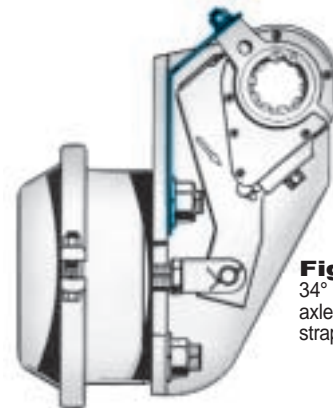

**Figure 6**  
34° drive axle with strap bracket

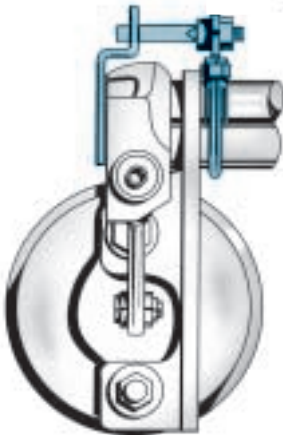

**Figure 7**  
Mack drive axle with clamp bracket and flat anchor stud

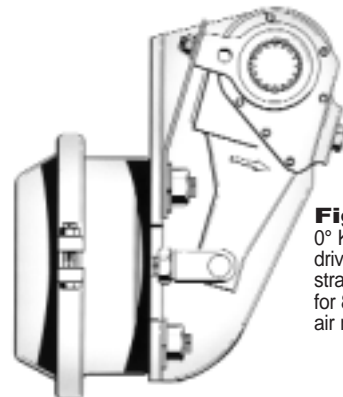

**Figure 8**  
0° Kenworth drive axle with strap bracket, for 8 bag air ride

**Note: Refer to fundamental parts identification and location on page 10.**

## Typical Applications

### Trailer Axle

Figures 9–12 show typical brackets for automatic brake adjuster applications on trailer axle brake assemblies. Refer to pages 4 and 5 for detailed installation procedures.

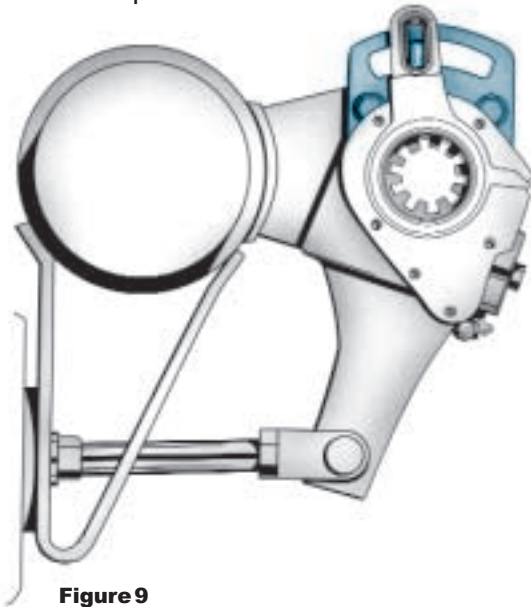

**Figure 9**  
For 16-1/2" Brake Assemblies



**Figure 10**  
For 12-1/4" Brake Assemblies

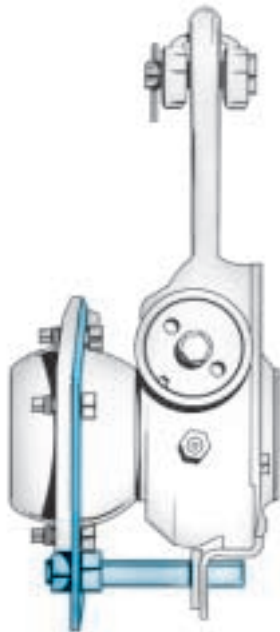

**Figure 11**  
Integral cam support anchor  
bracket for 12-1/4" and 16-1/2"  
brakes

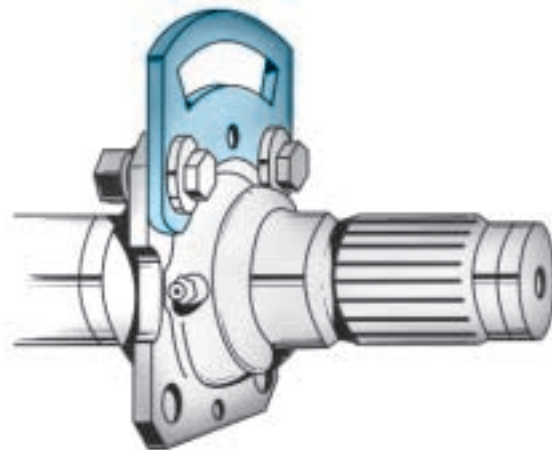

**Figure 12**  
Bolt-on cam support anchor  
bracket for 12-1/4" and 16-1/2"  
brakes

**Note: Refer to fundamental parts identification and location on page 10.**



## Installation Procedures

**Note: Configuration of anchor bracket and brake adjuster housing may vary, depending upon axle. Refer to typical applications on Page 2 and 3.**



### Step 1

**Note: Block wheels to prevent vehicle from rolling. Ensure system tank pressure is above 100 PSI.**

- Check that the push rod is fully retracted; apply air to release spring brake. If air is not available, spring brake must be manually caged back.
- Install anchor bracket loosely as illustrated (fig. 13).
- Some strap brackets have two mounting holes. Proper mounting location is determined by the length of adjuster arm. 5" and 5-1/2" adjuster arm lengths utilize the shorter hole location while 6" and 6-1/2" length adjusters utilize the longer hole locations.
- Do not tighten anchor bracket fasteners at this time.
- Apply "Anti-Seize" type lubricant to camshaft splines.

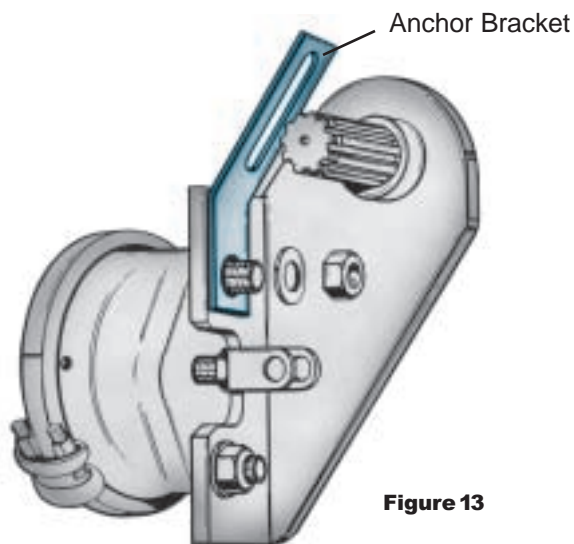

Figure 13

### Step 2

- Install the brake adjuster onto the camshaft with the adjusting hex pointing away from the brake chamber (fig. 14).
- Secure the brake adjuster on the camshaft. Use at least one inner washer and enough outer washers to allow no more than .060 movement of adjuster on camshaft. (Per TMC recommended practice RP609-A.)

**Note: Do NOT pull push rod out to meet the brake adjuster.**

- Rotate the 7/16" adjusting hex nut CLOCKWISE until the clevis hole lines up with the brake adjuster arm hole.
- Apply anti-seize to clevis pin, install and secure with cotter pin.

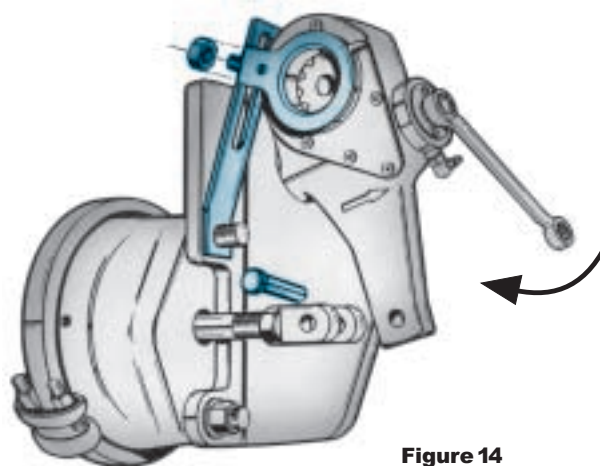

Figure 14

## Installation Procedures

### Step 3

- Rotate the control arm away from the adjusting hex toward the air chamber, until it comes to a definite internal stop (fig. 15).
- Most adjusters will be equipped with an "Installation Indicator." Indicator must fall within the slot for proper installation with brakes fully released (fig. 16).
- **If the control arm position is wrong, tight brakes will occur (fig. 17).**
- Tighten all anchor bracket fasteners (make sure the control arm does not move from its position while tightening fasteners).

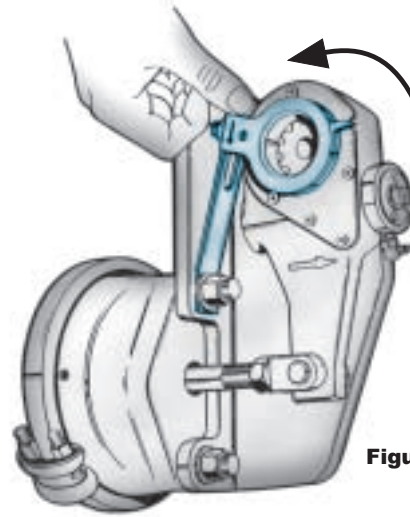
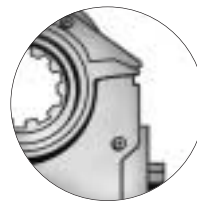

Figure 15



### Step 4

- The adjuster must be manually adjusted at this time.
- Rotate the adjusting hex clockwise until the lining lightly contacts the drum.
- Then back-off the adjuster by turning the adjusting hex counter-clockwise 1/2 of a turn (fig. 18).
- A minimum of 13 ft. lbs. is necessary to overcome the internal clutch. A ratcheting sound will be present.
- **Do NOT use an impact wrench or internal damage will occur!**
- **FINAL INSPECTION.** With full service brake application, assure that spring brakes are released, and check that the "Installation Indicator" is within the slotted area. **IF NOT, REPEAT Step 3.**



Correct  
(Brakes released)  
Figure 16

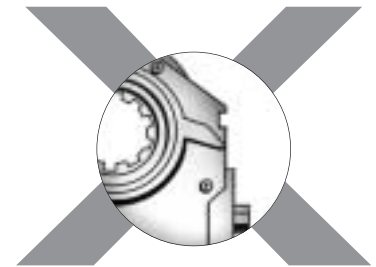

INCORRECT  
(Brakes released)  
Figure 17

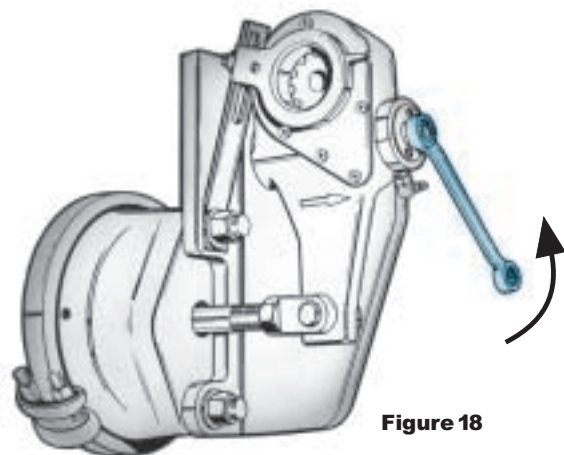

Figure 18

**Note: To ensure proper fit and function, always replace both adjuster and mounting bracket.**

## Routine Visual/Operational Checks

- **Haldex strongly recommends that routine visual/operational checks, including brackets and control arms, be performed at each Preventative Maintenance Service Interval.**
  
- **Adjusters or anchor brackets that have visual damage, or which fail the operational checks, MUST be replaced immediately.**
  
- **Automatic adjusters should not be operated as manual adjusters except as may be necessary to get the vehicle off the road for service.**

## Service and Lubrication Intervals

Adjuster Type	Manufacture Date	Lubrication Interval	Type of Lubricant	Visual Check Interval
Standard Adjuster 409-10...	Prior to 6/1/96	50,000 miles or every 3 months	Standard Chassis Grease	Each Preventative Maintenance Service Interval
Reduced Maintenance Adjuster 409-10...	After 6/1/96	Once a year	Standard Chassis Grease	Each Preventative Maintenance Service Interval
No-Lube™ Adjuster 429-10...	After 6/1/96	None	Sealed Unit	Each Preventative Maintenance Service Interval



### Notes:

No-Lube™ automatic brake adjusters are manufactured without a grease fitting and are identified by a 429 prefix.

Moly-disulfide grease should not be used because it may affect the function of the internal friction clutches and reduce the reliability of the automatic adjustment.

In no case should the lubrication interval exceed the published intervals shown above.





## Foundation Brake Operational Check and Troubleshooting

- Note:**
- Block wheels to prevent vehicle from rolling.
  - Ensure system tank pressure is at 90-100 psi.
  - Check that push rod is fully retracted; apply air to release spring brake.

### North American Commercial Vehicle Safety Alliance (CVSA) Uniform Vehicle Inspection Criteria

The applied stroke of the brake should be checked per CVSA guidelines at 90-100 PSI reservoir pressure. **Applied stroke** should be at or less than the specified adjustment limits as follows:

Standard Clamp Type Brake Chamber			
Type	Adjustment Limit	Type	Adjustment Limit
9	1-3/8"	24	1-3/4"
12	1-3/8"	30	2"
16	1-3/4"	36	2-1/4"
20	1-3/4"		

Long Stroke Type Brake Chamber			
Type	Adjustment Limit	Type	Adjustment Limit
16L	2"	24LS	2-1/2"
20L	2"	30LS	2-1/2"
24L	2"		

NOTE: Long stroke chambers are identified with square air ports or port bosses and special trapezoid ID tags.

## Free Stroke

### Measuring the Free Stroke

Free stroke is the amount of movement of the adjuster arm required to move the brake shoes against the drum. With brakes released, measure from the face of the chamber to the center of the clevis pin "A" (fig. 19). Use a lever to move the brake adjuster until the brake shoes contact the drum "B" (fig. 19). The difference between the fully retracted and drum contact measurement "B"–"A" (fig. 19), is the free stroke. The free stroke range should fall between 3/8"–3/4".

### Free Stroke Within Range

If the free stroke is good, but the applied stroke is too long, there is probably a problem with the foundation brake. Check the following and reference CVSA out-of-service criteria:

Component	Cause	Action
Brake drums	Cracked or out of round	Replace or check drum run out
Brake shoes	Shoe span out of spec	Refer to OEM specs and replace if necessary
Brake shoes	Uneven lining wear	Check spider concentricity
Brake shoes	Shoe pad missing	Remove & replace shoes
Brake shoes	Cracked shoes	Remove & replace shoes
Cam bushings	Excessive movement	Remove & replace cam bushings per OEM specs
Camshaft	Flat spots on cam head	Replace camshaft
Camshaft	Cracked/broken splines	Replace camshaft
Camshaft	Worn bearing journals	Replace camshaft
Chamber bracket	Broken/bent	Replace bracket
Clevis yoke and pin	Worn	Remove & replace
Return springs	Broken/stretched or missing	Remove & replace springs
Rollers	Flat spots, grooved pin/worn	Remove & replace roller and pin
Rollers	Wrong size	Remove & replace with correct parts
Spider anchor pins	Grooved or scored/worn	Replace spider or pins, as appropriate for OEM

### Free Stroke Above the Range

If the free stroke is above the range and the applied stroke is too long, there is a problem with the foundation brake or the adjuster. Check the following:

Component	Cause	Action
Camshaft	Binding	Remove, replace, lubricate camshaft
Camshaft bushings	Excessive movement	Remove and replace cam bushings per OEM specs
Camshaft bushings	Binding shaft	Lubricate camshaft bushings or replace
Air chamber return springs	Broken, weak, missing	Replace chamber
Air chamber push rod	Binding on chamber housing	Check adjuster for proper shimming and air chamber position for proper adjuster arm length
Air system	Not exhausting completely	Check for cause of air problem and repair
Shoe return springs	Broken, weak, missing	Replace springs
Automatic brake adjuster	Unknown	Check automatic brake adjuster for proper installation. Refer to Installation Instructions on pages 4 & 5.
Automatic brake adjuster	Unknown	Refer to Automatic Brake Adjuster Checking Procedures and Operational Check on pages 9 & 10.

### Free Stroke Below the Range

If the free stroke is less than 3/8", a dragging brake can occur. Check the following:

Component	Cause	Action
Wheel bearing	Out of adjustment	Readjust per OEM specs
Automatic brake adjuster	Unknown	Check automatic brake adjuster for proper control arm position. Refer to Installation Instructions on pages 4 & 5.
Automatic brake adjuster	Unknown	Refer to Automatic Brake Adjuster Checking Procedures and Operational Check on pages 9 & 10.

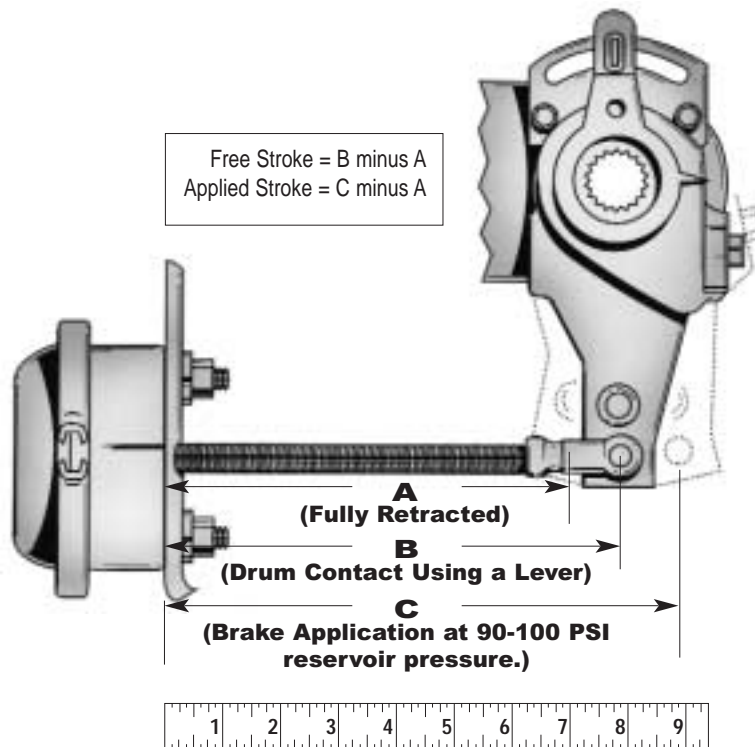

**Figure 19**  
Stroke Measurements  
(taken from face of air chamber  
to center of clevis pin)

## Automatic Brake Adjuster Checking Procedures

If the brake adjuster is not maintaining the proper applied stroke, before removing the brake adjuster, check the condition of the foundation brake (see pages 7 & 8). **If after inspecting the foundation brake** no apparent problems are found, inspect the automatic brake adjuster to determine if it is operating properly. The inspection can be performed on or off the vehicle using the following procedures.



- Note:**
- Block wheels to prevent vehicle from rolling.
  - Ensure system tank pressure is at 90-100 PSI.
  - Check that push rod is fully retracted; apply air to release spring brake.
  - If air is not available, spring brake must be manually caged back.
  - Do not use air tools on brake adjuster!

## On Vehicle Inspection

Component	Cause	Action
Tight or dragging brakes	Control arm mispositioned	Realign control arm and anchor bracket. Check installation procedures on pages 4 & 5.
Excessive chamber push rod travel	Improper anchor bracket connection to control arm	If anchor bracket to control arm connection is worn, loose, bent or broken, it must be re-secured or replaced.
	Low clutch torque	Rotate the 7/16" adjustment hex one full turn counterclockwise. Replace brake adjuster if the torque is <u>less than 13 ft. lbs.</u> or no ratcheting sound occurs.
	Unknown	Perform automatic brake adjuster operational check (see below).

## Automatic Brake Adjuster Operational Check

**Functional operation of the brake adjuster can be performed on the vehicle by using the following procedure:**



- Block wheels to prevent vehicle from rolling.
- Ensure tank pressure is at 90-100 psi.
- Check that the push rod is fully retracted; apply air to release spring brake. If air is not available, spring brake must be manually caged back.

Manually de-adjust brakes (turn adjustment hex counterclockwise one full turn) to create an excessive drum to lining clearance condition. (A ratcheting sound should occur.)

Make a full service brake application. On release, allow sufficient time for brake to fully retract.

During the brake release, observe rotation of the adjustment hex (attaching a wrench on the hex or scribing the hex will make this rotation easier to see).

This rotation indicates that an excessive clearance condition has been determined by the brake adjuster, and it is making an adjustment to compensate. On each subsequent brake release, the amount of adjustment and push rod travel will be reduced until the desired clearance is achieved.

If rotation of the adjustment hex is not observed, refer to Foundation Brake Operational Check and Troubleshooting Procedures on pages 7 and 8. If foundation brake assembly checks out okay and hex still does not turn, check control arm and mounting bracket for possible worn, bent or broken components. If the control arm and mounting bracket check out okay, replace the adjuster and hardware per procedures on pages 4 & 5.

## Off Vehicle Inspection

Component	Cause	Action
Adjuster not functioning properly	Low clutch torque	Place adjuster arm in vise. Rotate the 7/16" adjustment hex counterclockwise one full turn to check de-adjustment torque. After control arm stops rotating, a minimum of 13 ft. lbs. will be required and a ratcheting sound will occur. Replace brake adjuster if the torque is <u>less than 13 ft. lbs.</u> or no de-adjustment ratcheting sound is present.
	Control Arm slippage	Place adjuster arm in vise. Rotate the control arm counterclockwise until the control arm rotates to an INTERNAL STOP. If the installation indicator goes past the indicator notch or does not stop rotating (arm slips freely), replace the brake adjuster.
	Unknown	If torque is above 13 ft. lbs., scribe a line on the adjustment hex. Manually pull the brake adjuster control arm clockwise then push back counterclockwise until the installation indicator stops in the indicator notch. The hex will move in a clockwise direction when the control arm of the brake adjuster is pushed back counterclockwise. Replace adjuster is hex does not move.
	Worn/missing control arm wear bushing, and anchor stud pin, if applicable.	Remove and replace pin and bushings. If adjuster has passed the above checks, re-install adjuster on vehicle, with new hardware.

## Typical Parts Identification and Location

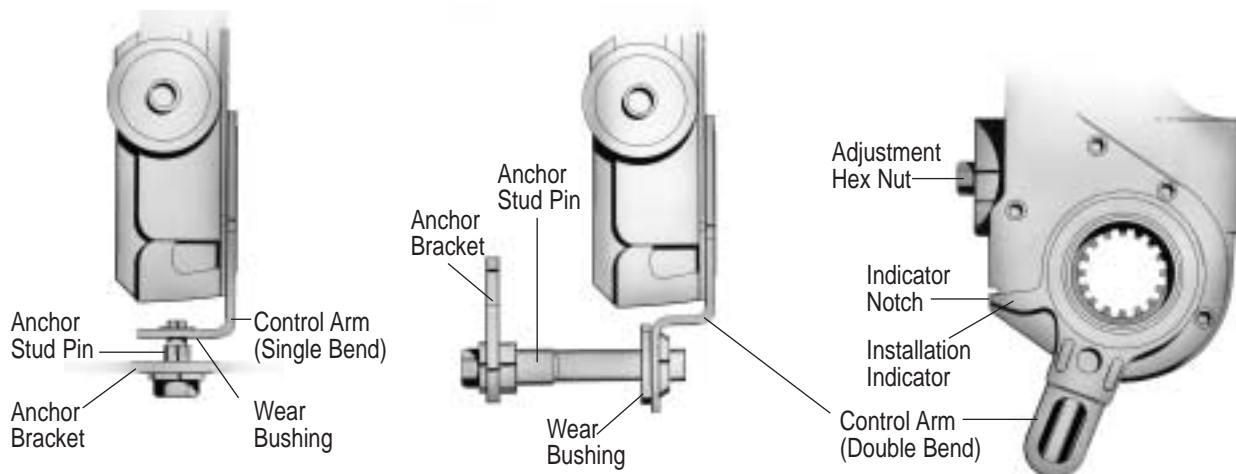

# Torque Specifications

**Note: Tighten all fasteners to manufacturer's recommendations unless otherwise specified below.**



**Round Anchor Stud Pin with Fabricated Ring Clamp**  
Torque to 15-20 ft. lbs. when installed

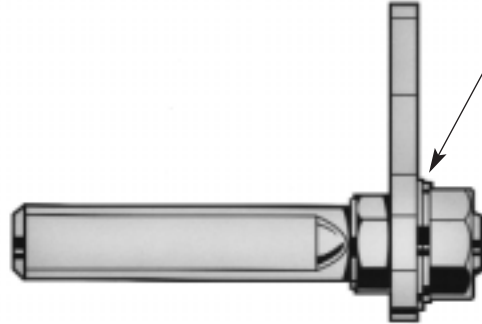

**Flat Anchor Stud Pin**  
Torque to 40-50 ft. lbs. when installed

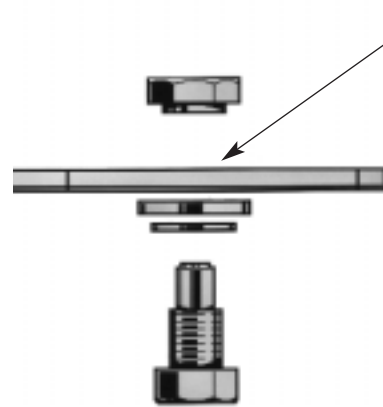

**Round Anchor Stud Pin with Slide Nut**  
Torque to 15-20 ft. lbs. when installed

**3/8"-16 Nut and Bolt**  
Torque to 15-20 ft. lbs. when installed

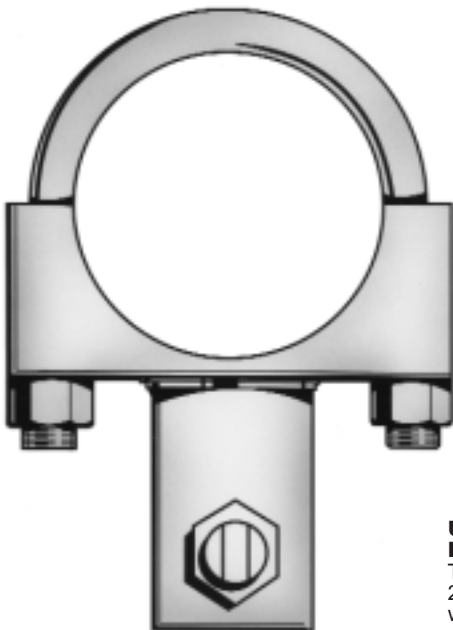

**U-Bolt Style Bracket**  
Torque to 20-30 ft. lbs. when installed

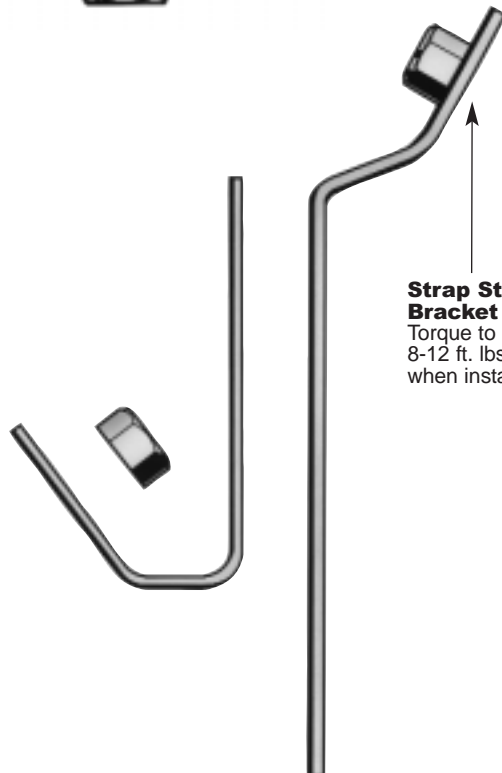

**Strap Style Bracket**  
Torque to 8-12 ft. lbs. when installed

---

## Frequently Asked Questions

**1. Will the side of the brake adjuster with the installation indicator always face in?**

No. Haldex adjusters are normally unhandled. Always install with the adjusting hex pointing away from the air chamber.

**2. My adjuster doesn't have an installation indicator; should I be concerned?**

No. A few applications aren't manufactured with installation indicators. However, the set-up and function are the same regardless. Refer to pages 4 & 5 for proper installation procedures.

**3. Why is there resistance when backing off the adjuster?**

It takes approximately 20-25 lb. ft. of torque to back off the adjustment hex. (A ratcheting sound should occur.)

**4. How far do I back off the automatic brake adjuster at a brake reline?**

1/2 turn. (NOTE: for the first 1/8 turn you may not hear the ratcheting; this is normal.)

**5. How do I know if I need an offset, angled or straight-armed adjuster?**

Haldex manufactures the right adjuster arm for your specific application. Haldex adjusters are unhandled (no lefts or rights) in the majority of applications. Please refer to the Haldex Parts and Cross Reference Guide for your specific application (ABA10001).

**6. Why does my replacement ABA look different from the original I took off?**

The Haldex ABA replacement adjuster has been designed to fit a number of applications. It is the same original equipment quality and design of the adjuster you removed; however, it may look different on the outside. If you use all the parts included in the kit, the results will be the same as the original equipment adjuster.

**7. Why is the applied stroke pressure range 90-100 psi at the reservoir?**

This is the pressure recommended by the CVSA (Commercial Vehicle Safety Alliance). Anything beyond 100 psi measures deflection within the foundation brake and not true push rod stroke.

**8. Some brake chambers have round port openings and some square; what is the difference?**

Standard brake chambers are identified by round ports. Long stroke chambers are identified by square ports and trapezoid ID tags.

**9. Can I vary the amount of lining-to-drum clearance by moving the control arm?**

No, that clearance is set at the factory. If long or short stroke continues, please refer to the foundation brake checking procedures on pages 7 & 8 of this manual.

**10. Can I use an air ratchet on the adjuster?**

No. It will damage the internal mechanism of the adjuster and render it inoperative.

**11. Can I access the adjuster through the rear cover?**

No, do not tamper with the rear cover—it will release the factory set pressure on the spring and destroy the adjuster and its ability to properly function.

**12. How much control arm bushing and anchor stud pin wear is acceptable before replacement is required?**

No more than 1/16."

**13. What is the acceptable amount of camshaft bushing wear?**

Automatic adjusters cannot compensate for worn foundation brake parts. Please refer to the foundation brake manufacturer's recommendations for maximum bushing and camshaft wear limits.

**14. Can wheel bearing adjustment affect the brake adjuster?**

Yes. Improper wheel bearing adjustment could result in improper brake adjustment. It is necessary to refer to the axle manufacturer's wheel bearing adjustment recommendations. A loose bearing preload could cause a tight brake.

(continued on page 13)



## Frequently Asked Questions (continued)

### 15. Are all Haldex automatic brake adjusters pre-lubed?

Yes. All Haldex brake adjusters are lubricated at the factory. Please consult the Service and Lubrication Section on Page 6 for proper lubrication guidelines.

### 16. Can I use moly lube with the Haldex automatic brake adjuster?

No. A high concentration of moly-disulfide can lower the friction capabilities in the adjusting clutch parts and decrease automatic adjustment reliability.

### 17. Can I purchase anchor bracket wear items separately (i.e., anchor stud pins, wear bushings)?

Yes. Normal wear items like anchor stud pins and wear bushings are available. Refer to the Haldex Parts and Cross Reference Guide, ABA10001. Otherwise, contact Haldex Technical Assistance for the appropriate bracket kit at 1-800-643-2374.

### 18. Does the control arm need to be properly set and secured?

Yes. Without proper placement and attachment, the adjuster will not function properly. Make sure the control arm, anchor bracket and wear items are in good working order to assure the adjuster will operate as designed.

### 19. If automatic adjustment stops, can I operate as a manual brake adjuster?

No. Completely check out foundation brake and adjuster to determine cause of problem. Repair or replace as needed to restore automatic adjustment.

## Additional Information Available

Additional parts and service information on Haldex Automatic Brake Adjusters may be found in the following materials:

### Service Information

Installation and Maintenance Wall Chart . . . . .	L60047HBS
Installation Video . . . . .	ABA10017
Service Manual (Truck/Trailer) . . . . .	L30033HBS

### Parts Information

Parts and Cross Reference Guide (Truck/Trailer) . . .	ABA10001
Supplemental Automatic Brake Adjuster Kits . . . . .	ABA10007

These materials may be ordered by contacting your Customer Service Representative at 1-800-643-2374. Or, you may log in to our website [www.hbsna.com](http://www.hbsna.com) with your customer password to place your order.







## Commercial Vehicle Systems

North American Sales Division  
Haldex Brake Products Corporation  
10707 N.W. Airworld Drive  
Kansas City, MO 64153-1215  
Phone: (816) 891-2470  
Fax: (816) 880-9766

North American Sales Division  
Haldex Limited  
525 Southgate Drive, Unit 1  
Guelph, Ontario CANADA N1G 3W6  
Phone: (519) 826-7723  
Fax: (519) 826-9497

[www.hbsna.com](http://www.hbsna.com)