

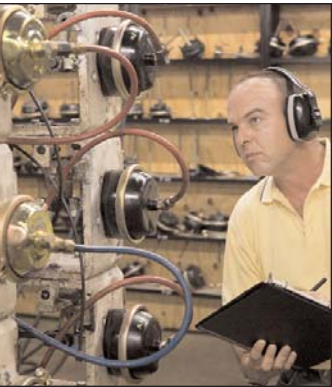

Haldex
Gold Seal® Actuators
For Reliable
Performance

L20436

Rev. 1/05



ACTUATORS

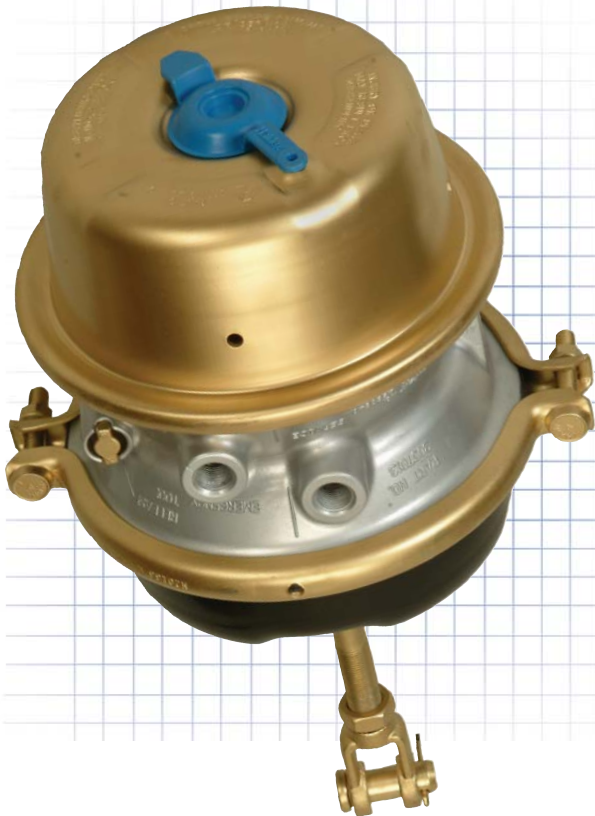

Haldex Gold Seal® Actuators

Durability and Reliability Mile After Mile



ACTUATORS

Haldex is both an industry pioneer and market leader in air brake actuators. Many of the designs and features you have come to expect are Haldex innovations. We continue to set the industry standard for design, reliability and extended product life today and into the future.

By using advanced manufacturing processes and high-grade, quality materials, Haldex Gold Seal® Actuators assure lower operating costs and deliver long-lasting durability, performance and reliability for outstanding value mile after trouble-free mile.

Engineered Tough

Unlike our competitors who use inferior "off-the-shelf" components, Haldex engineers all of our materials to strict standards. Utilizing specially designed components like our patented power spring, we maximize output force and extend the life of the actuator. Longer life means few replacements, which saves you money.

Built Tough

Haldex manufacturing facilities are both ISO and QS certified. These disciplines ensure each actuator exceeds your expectations. Competitor units may look similar but lack many of the corrosion protection features of Gold Seal. The integral rolled seal on the spring housing maintains the protective coating even after assembly.



Guaranteed to Endure

Haldex Gold Seal is guaranteed with four-year, unlimited mileage warranty coverage*. All the design features and benefits of Gold Seal add-up to save you time and money by reducing your maintenance and downtime expenses.

Haldex has the Actuator You

Need Haldex offers a complete family of actuators designed and built to the same high standards. The Gold Seal family includes twelve different sizes ranging from the popular 3030 2.5" stroke to the 1624 2.25" stroke and 3636 3.0" stroke. A complete listing of our product line is included here.

*See Haldex Warranty Policy Number L20221 for details.

GOLD SEAL

PREMIUM PILOTED DIAPHRAGM for straight spring cycling and longer diaphragm life.

CAGING TOOL with ACME threads makes caging quick, convenient and easy.

DOUBLE O-RING CENTER SEAL AND UNIQUE WEAR RINGS extend service life and protect against air leakage between chambers.

ORBITAL RIVETED ADAPTER PUSH ROD DISCS permanently attached for durability.

PATENTED ORANGE ALERT STROKE INDICATOR is visible when brakes are out of adjustment.

ZINC PLATED PUSH ROD for added corrosion protection.

PATENTED PILOTED DUST SHIELD is designed to enhance automatic brake adjuster operation by maintaining push rod alignment and reducing contaminants in the service chamber.

ALUMINUM CENTER BODY is durable and lightweight.

EPOXY COATED 9-GAUGE STUD HOUSING for maximum strength.

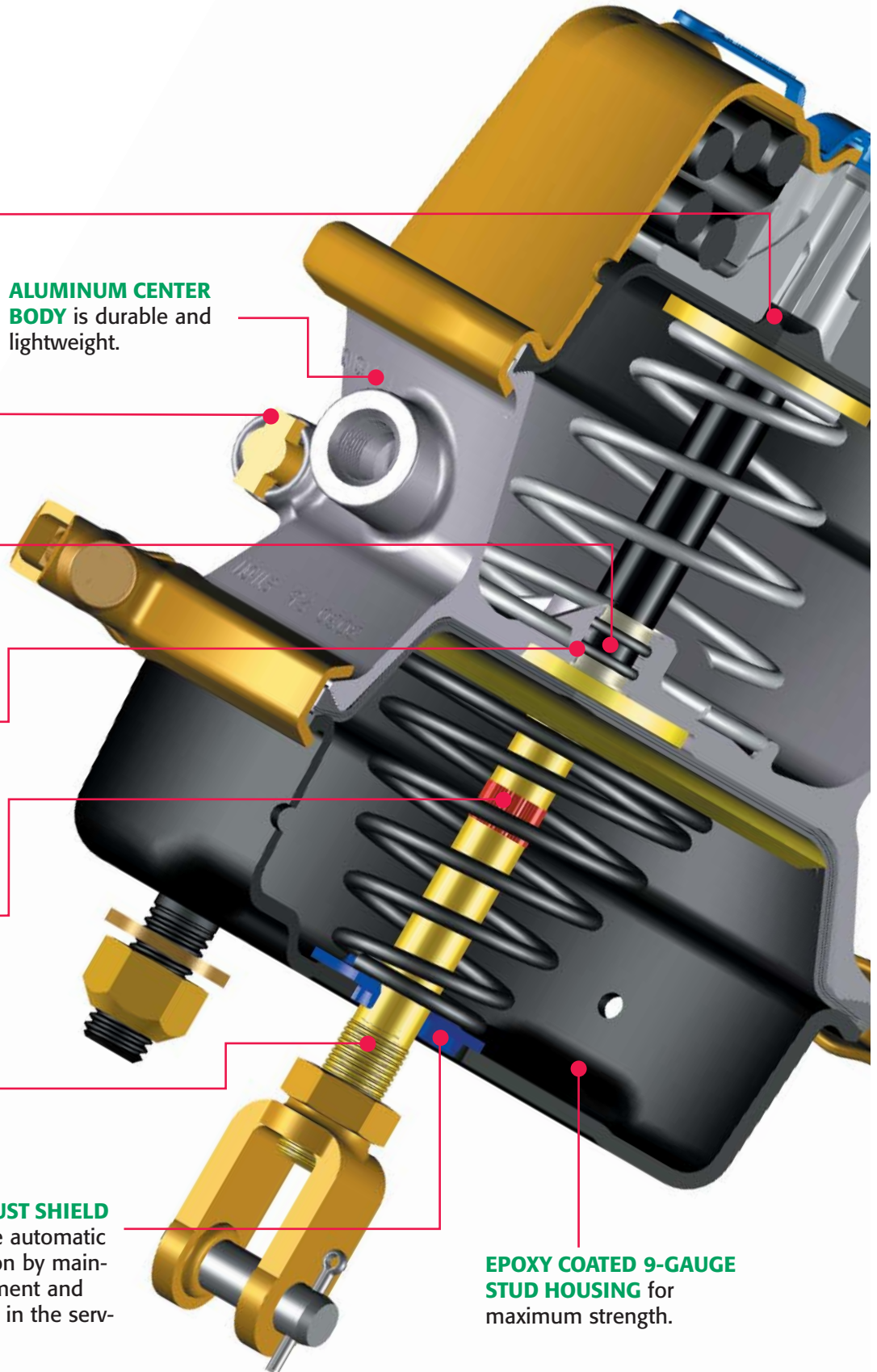

GOLD SEAL

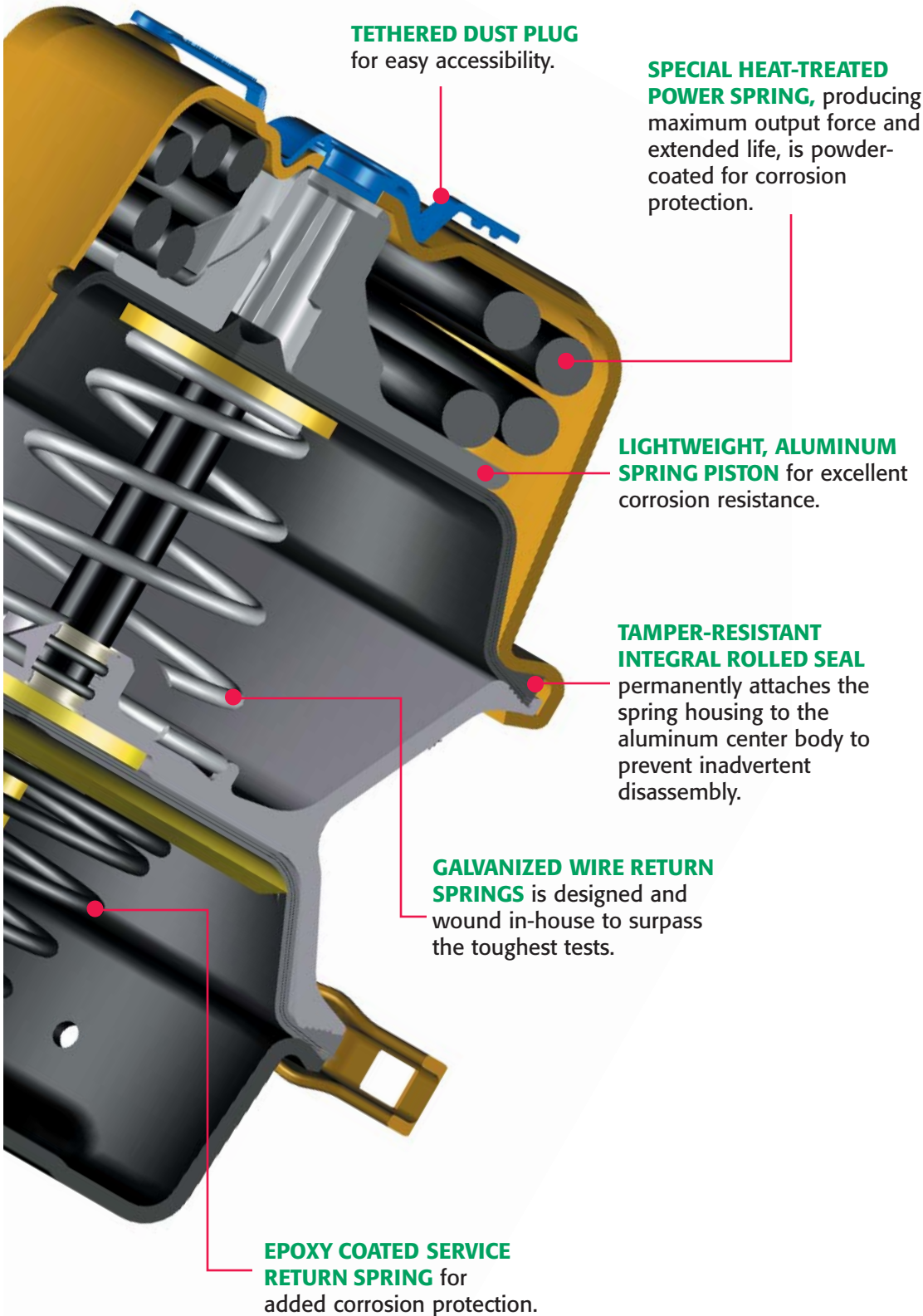

Tested For Reliability

To ensure toughness, each Haldex actuator is 100% leak tested and date stamped for traceability. All product testing is performed at our in-house laboratory according to SAE J1469. Actuators are heat tested to over 158°F (70°C) and cold tested to -40°F (-40°C). To ensure critical component integrity and peak performance under various conditions, each model unit has been pressure tested to over 300 psi.

In addition, actuators are vibration tested to OEM engineering criteria and performance tested on regular intervals. We test components for strength and durability to exceed our own strict engineering requirements.



Haldex Gold Seal Piggyback Replacement Kit

After years of faithful service, it may become necessary to replace your Gold Seal Actuator. Order the genuine Haldex Gold Seal Piggyback Replacement Kit. The kit includes one each of the Gold Seal Piggyback actuator, a premium Haldex service diaphragm and a new double clamp assembly. For ease of handling each kit is individually boxed.

Your replacement kit carries the same warranty as the original equipment, four-year unlimited mileage. Step up to a six-year unlimited mileage warranty with a Life Seal Piggyback Replacement Kit.

Contact the Haldex Technical Service Department at 800-643-2374 for additional details.



Advantages of Long Stroke Actuators

When compared to a standard stroke, Haldex Long Stroke Actuator provides a higher and more constant force output.

As wear and heat take effect on the foundation brake system, the extra stroke and additional output force is required to maintain braking. The result is more available power to stop your vehicle.



PART NUMBER: GP3030K

TO MINIMIZE SERVICE SIDE AIR LEAKS, HALDEX RECOMMENDS REPLACING BOTH THE SERVICE CLAMP AND SERVICE DIAPHRAGM DURING PIGGYBACK REPLACEMENT.

Haldex Actuator Product Offering

Gold Seal - 12 available sizes

Service Chamber - 11 available sizes

Clamp Style - 5 available sizes

Wedge Brake - 2 service chambers and 4 double diaphragm available sizes

Air Disc Service Chamber - 3 available sizes

Air Disc Double Diaphragm - 4 available sizes

Blue Seal - 3 available sizes for the European Market

Anchorlok and Maxibrake Products - including the R-Series, Camtite and Type 50 actuators

Haldex offers proprietary vehicle technology solutions to the global vehicle industry within specific niches. We focus on products to improve safety, the environment and vehicle dynamics.

We are enhancing our competitive capabilities and building long-term customer relationships through high performance, low total costs to the customer through the product's service life, ethical business practices and commitment to long-term partnerships. Haldex operations are divided into four business areas: Commercial Vehicle Systems, Hydraulic Systems, Garphyttan Wire and Traction Systems.

Austria

Haldex Wien Ges.m.b.H.
Vienna
Tel.: +43 1 8 65 16 40
Fax: +43 1 8 65 16 40 27
E-Mail: info.austria@haldex.com

Belgium

Haldex N.V./S.A.
Balegem (Ghent)
Tel.: +32 9 363 90 00
Fax: +32 9 363 90 09
E-Mail: info.hbe@haldex.com

Brazil

Haldex do Brasil
São Paulo
Tel.: +55 11 213 55 000
Fax: +55 11 503 49 515
E-Mail: info@hbr.haldex.com

Canada

Haldex Ltd
Guelph, Ontario
Tel.: +1 519 826 7723
Fax: +1 519 826 9497
E-Mail: CSCanada@haldex.com

China

Haldex International Trading Co. Ltd.
Shanghai
Tel.: +86 21 5240 0338
Fax: +86 21 5240 0177
E-Mail: info@hcn.haldex.com

France

Haldex Europe SAS
Weyersheim (Strasbourg)
Tel.: +33 3 88 68 22 00
Fax: +33 3 88 68 22 09
E-Mail: info.heu@haldex.com

Germany

Haldex Brake Products GmbH
Heidelberg
Tel.: +49 6221 7030
Fax: +49 6221 703400
E-Mail: info@haldex.com

Hungary

Haldex Hungary Kft.
Szentlőrincváta
Tel.: +36 29 631 300
Fax: +36 29 631 301
E-Mail: info.hu.eu@haldex.com

India

Haldex India Limited
Nasik
Tel.: +91 253 2380094
Fax: +91 253 2380729
E-Mail: haldex@haldexindia ltd.com

Italy

Haldex Italia Srl.
Muggio (Milano)
Tel.: +39 039 278 23 50
Fax: +39 039 796 525
E-Mail: info@hit.haldex.com

Poland

Haldex Sp. z.o.o.
Praszka
Tel.: +48 34 350 11 00
Fax: +48 34 350 11 11
E-Mail: info@haldex.net.pl

South Korea

Haldex Korea Ltd.
Seoul
Tel.: +82 2 2636 7545
Fax: +82 2 2636 7548
E-Mail: info.hkr@haldex.com

Russia

OOO Haldex RUS
Moscow
Tel.: + 7 495 747 59 56
Fax: +7 495 786 39 70
E-Mail: info.russia@haldex.com

Spain

Haldex España S.A.
Parets del Valles (Barcelona)
Tel.: +34 93 573 10 30
Fax: +34 93 573 07 28
E-Mail: haldexespana@haldex.com

Sweden

Haldex Brake Products AB
Landskrona
Tel.: +46 418 47 60 00
Fax: +46 418 47 60 01
E-Mail: info@hbpse.haldex.com

United Kingdom

Haldex Ltd.
Newton Aycliffe
Tel.: +44 1325 310 110
Fax: +44 1325 311 834
E-Mail: aycliffe.info@haldex.com

Haldex Brake Products Ltd.

Redditch
Tel.: +44 1527 499 499
Fax: +44 1527 499 500
E-Mail: info@haldex.com

USA

Haldex Brake Products Corp.
Kansas City, MO
Tel.: +1 816 891 2470
Fax: +1 816 891 9447
E-Mail: hbsna@haldex.com

©2007, Haldex AB - This material may contain Haldex trademarks and third party trademarks, trade names, corporate logos, graphics and emblems which are the property of their respective companies. The contents of this document may not be copied, distributed, adapted or displayed for commercial purposes or otherwise without prior written consent from Haldex.

