

2010

Haldex

L20243

Rev. 11/10



ABS

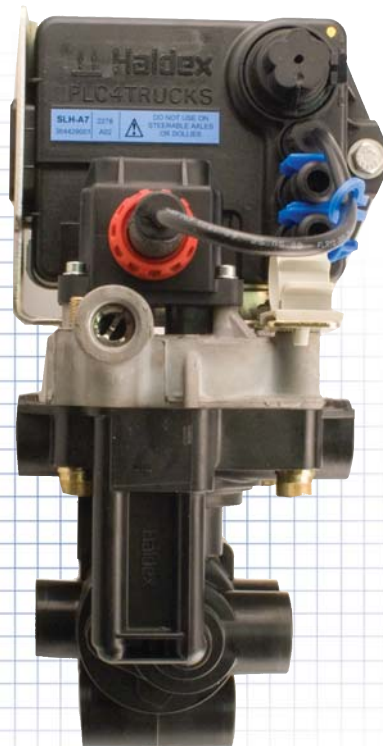

www.haldex.com

02 – ABS

Table of Contents	02–1
Part Number Index	02–3
General Information	
Foreword	02–5
Trailer ABS Component Overview	02–6
Anti–Lock Braking System – Trailer	
2S/1M ABS Relay Valve Kits for Dollies and Single Axle Applications	02–8
2S/1M FFABS Valve Kits for Multi–Axle Applications	02–9
2S/1M ABS Relay Valve Kits for Multi–Axle Applications	02–10
4S/2M ABS Kits (Primarily Competitive Change–out)	02–11
4S/2M ABS Kits (New Trailer)	02–12
ECU Upgrade Kits	02–13
ABS Valves	
Solenoid Kit	02–14
FFABS 2 & 4–Port Delivery	02–15
ABS Relay 2 & 6–Port Delivery	02–16
ABS ECUs	
PLC Select 1M and 2M	02–17
PLC/PLC Plus	02–18
Power Cords	
Full Power Cables	02–19
Power Cord Extensions	02–20
Looms	02–21
Sensors	02–22
Sensor Extensions	
Universal Sensor Extensions	02–23
ABS Adapter Cables – DIN and pre–DIN Systems	02–24
ABS Valve Cable Extensions – DIN and pre–DIN Systems	02–25
PLC Select 2M and PLC Select Plus Remote Valve Cable – DIN and pre–DIN Systems	02–26
PLC Select Plus Auxiliary Interface Cables	02–27
Trailer Roll Stability (TRS) Applications	02–28
Labels & Decals	02–29
Diagnostics & Displays	
Electronic Odometer	02–30
ABS PC Diagnostic Kits (PC not included)	02–31
Installation Components & Accessories	
ABS Trailer Lights & Components	02–32
ECU/Valve Brackets & Loom Clasps	02–33

Sensor Accessories/Blocks & Exciter Ring	02-34
Miscellaneous ABS Components	02-35
Brake Monitoring System (BMS-1)	02-36
Anti-Lock Braking System – Truck/Tractor/Bus	
Remanufactured Meritor WABCO Style ABS Valve Assemblies	
Rear Axle Valve Packs	02-37
Relay Valve for Valve Pack	02-40
Front Axle Valve Packs	02-41
Quick Release Valve for Valve Pack	02-42
Modulator Valves	02-43
Remanufactured Meritor WABCO Style ATC Valves	02-45
Meritor WABCO Style Converter Cables	02-46
All Makes ABS Components for Haldex, WABCO and Bosch	
Sensors	02-47
Sensor Extension	02-48
Sensor Accessories	02-49
Maintenance	
Trailer OEM Assemblies	02-50



Haldex Trailer ABS Systems utilize many common valve and sensor components in all our ABS product offerings. Loom Assemblies and Electronic Control Units (ECU) will vary by ABS family. The illustrations below are representative of five families of product offerings. System identification and components reference can be easily found using these illustrations. Application notes are included in the catalog pages to aid in accurate service requirements. See ABS Service-Installation Manuals for specific component usage, including but not limited to L30030 and L30041.

Haldex ECU and Looms have mating connectors (numbers of pins and keys). Please exercise caution when replacing these items and follow the catalog references carefully. Contact your Haldex Commercial Vehicle Systems representative if additional information is required.

ECU Platforms

		
PLC ECU 19 PIN (Ref: AL919311)	PLC Select 1M ECU (Ref: AL919338)	PLC Select 2M ECU (Ref: AL919342)

ABS Valve Platforms

	
FFABS Valve (Ref: AL430670)	ABS Relay Valve (Ref: AL364040) Requires separate Spring Brake Control Valve such as Haldex N34031A

Sensor Components



Sensor 90° with Clip
(Ref: AL10271914)



Sensor Block
(Ref: A920802)



Sensor Extension
(Ref: AL919802)

ABS Cables & Wiring Looms Components



(Ref: AL929818)
DIN Style

Remote PLC Select 2M Valve Cable



2S/1M PLC Loom
(Ref: AL40900)
4S/2M Looms have added leads; 2 Sensors and 1 Valve Cable



(Ref: AL919812)
pre-DIN Style

ABS Relay Valve Cable Extension



(Ref: AL929812)
pre-DIN Style



(Ref: AL919819)
DIN Style

Optional Power Cord Components



Power Cable Extension
(Ref: 201199PA Series)



Power Cord with ABS Lamp Lead
(Ref: 201186RA Series)

Optional Miscellaneous Components



ABS Lamp
(Ref: AQ15463)



Sensor-to-Extension Grip
(Ref: A902700)



Sensor-to-Hose Clip
(Ref: AL920809)

2S/1M ABS Relay Valve Kits for Dollies and Single Axle Applications



Features:

- New Trailer and Competitive Replacement
- Cost Effective solution for competitive system change-out.
- ECU and ABS Valve designed to be serviced separately.

Specifications:

ECU Design PLC Select
 Valve Type ABS Relay

Notes:

- 1) ABS Relay Valve system requires an additional separate spring brake control valve, such as Haldex **KN26120** (N34031A).
- 2) **Do Not** use this kit to replace the Haldex Full Function ABS (FFABS) System.
- 3) Most ABS maintenance involves Wheel-end Sensors. Haldex recommends that Wheel-end Sensors be replaced when replacing or upgrading the ABS system.

SKU#	Product Description	ECU/Valve Number	Valve Specifications	Kit Contents other than Valve/ECU Assemblies
AQ960505	2S/1M Kit	N9001A	2-Port, 1/2" Res. Port 12V, 3/8" Control 3/8" Delivery	6.0m Power Cord Extension 2.5m Sensors (90°) & Clips

2S/1M FFABS Valve Kits for Multi-Axle Applications



Typical – AQ960802 Shown

Features:

- New Trailer Placement
- For Non-Steer Axles
- Patented FFABS Valve with integral Spring Brake Control function
- Pre-installed Reservoir Nipple with swivel and lock-nut feature assures easy serviceability
- ECU and ABS Valve designed to be serviced separately

Specifications:

ECU Design PLC Select

Valve Type FFABS

Notes:

- 1) Kit content varies / see below for details (20x12M Power Cord is 20m Power Cord with 12m ABS Lamp Lead).
- 2) Most ABS maintenance involves Wheel-end Sensors. Haldex recommends that Wheel-end Sensors be replaced when replacing or upgrading the ABS system.

SKU#	Product Description	ECU/Valve Number	Valve Specifications	Kit Contents other than Valve/ECU Assemblies
AQ960208	2S/1M Kit	N9001BB	4-Port, 3/4" Nipple 12V, 3/8" Ports Spring Brake Priority	20x12m Power Cord 2.5m Full Sensors (90°) & Clips
AQ960802	2S/1M Kit	N9001BB	4-Port, 3/4" Nipple 12V, 3/8" Ports Spring Brake Priority	20x12m Power Cord ABS Light Kit 2.5m Sensor Extensions
AQ961402	2S/1M Kit	N9001BB	4-Port, 3/4" Nipple 12V, 3/8" Ports Spring Brake Priority	2.5m Sensor Extensions
AQ961404	2S/1M Kit	N9001BB	4-Port, 3/4" Nipple 12V, 3/8" Ports Spring Brake Priority	6.0m Power Cord Extension 2.5m Sensor Extensions

2S/1M ABS Relay Valve Kits for Multi-Axle Applications



Typical – AQ960503 Shown

Features:

- Competitive Replacement
- For Non-Steer Axles
- Cost Effective solution for competitive system change-out
- ECU and ABS Valve designed to be serviced separately

Specifications:

ECU Design PLC Select

Valve Type ABS Relay

Notes:

- 1) ABS Relay Valve system requires an additional separate spring brake control valve, such as Haldex **KN26120** (N34031A).
- 2) **Do Not** use this kit to replace the Haldex Full Function ABS (FFABS) System.
- 3) Kit content varies / see below for details.
- 4) **AQ960514 & AQ960515** replaces MBS1, MBS1P and MBS2 (MBS2 requires optional wheel-end hardware kits to upgrade installation from in-axle Sensing: AQ15457 uses Sensor Blocks; AQ15458 uses Sensor Brackets).
- 5) Most ABS maintenance involves Wheel-end Sensors. Haldex recommends that Wheel-end Sensors be replaced when replacing or upgrading the ABS system.

SKU#	Product Description	ECU/Valve Number	Valve Specifications	Kit Contents other than Valve/ECU Assemblies
AQ960503	2S/1M Kit	N9001AA	6-Port, 1/2" Res. Port 12V, 3/8" Control 3/8" Delivery	6.0m Power Cord Extension 3.0m Sensor Extensions
AQ960510	2S/1M Kit	N9001AA	6-Port, 1/2" Res. Port 12V, 3/8" Control 3/8" Delivery	6.0m Power Cord Extension 2.0m Sensor Extensions
AQ960514	2S/1M for MBS WNC Change-out (Max)	N9001ZA	4-Port, 1/2" Res. Port 12V, 3/8" Control 3/8" Delivery Special Mounting Bracket	6.0m Power Cord Extension 2.5m Sensors & Clips All Misc. Hardware Required
AQ960515	2S/1M for MBS WNC Change-out (Lite)	N9001ZA	4-Port, 1/2" Res. Port 12V, 3/8" Control 3/8" Delivery Special Mounting Bracket	6.0m Power Cord Extension 2.5m Sensors & Clips

4S/2M ABS Kits (Primarily Competitive Change-out)



AQ963002 Shown

Features:

- Cost Effective solution for competitive system change-out
- ECU and ABS Valve designed to be serviced separately
- Patented FFABS Valve with integral Spring Brake Control function
- Pre-installed Reservoir Nipple with swivel and lock-nut feature assures easy serviceability

Specifications:

ECU Design PLC Select 2M
Valve Type FFABS

Notes:

- 1) Kit content varies / see below for details.
- 2) Most ABS maintenance involves Wheel-end Sensors. Haldex recommends that Wheel-end Sensors be replaced when replacing or upgrading the ABS system.

SKU#	Product Description	ECU/Valve Number	Valve Specifications	Kit Contents other than Valve/ECU Assemblies
AQ963002	4S/2M Kit for Tri-Axles	N9002BB	4-Port, 3/4" Nipple 12V, 3/8" Ports Spring Brake Priority	6M Power Cord Extension 1.5M & 2.5M Sensor Extensions 2-Port Relay Valve 2M Valve Relay Cable Hose Clips, Cable Grips, Labels
AQ963011	4S/2M Kit for Tandem Axles	N9002BF	2-Port, 3/4" Nipple 12V, 3/8" Ports Spring Brake Priority	6M Power Cord Extension 1.5M & 2.5M Sensor Extensions 2-Port Relay Valve 2M Valve Relay Cable Hose Clips, Cable Grips, Labels

4S/2M ABS Kits (New Trailer)



AQ963005 Shown

Features:

- New Trailer Build solutions
- ECU and ABS Valve designed to be serviced separately

Specifications:

ECU Design PLC Select 2M
Valve Type ABS Relay or FFABS

Notes:

- 1) ABS Relay Valve systems requires an additional separate spring brake control valve, such as Haldex **KN26120** (N34031A).
- 2) Kit content varies / see below for details.
- 3) Most ABS maintenance involves Wheel-end Sensors. Haldex recommends that Wheel-end Sensors be replaced when replacing or upgrading the ABS system.

SKU#	Product Description	ECU/Valve Number	Valve Specifications	Kit Contents other than Valve/ECU Assemblies
AQ963004	4S/2M ABS Relay Valve Kit for Tandem Axles	N9002A	2-Port, 1/2" Res. Port 12V, 3/8" Control 3/8" Delivery	6.0m Power Cord Extension 1.5m & 2.5m Sensor Extensions 2-Port Relay Valve 2.0m Valve Relay Cable Hose Clips, Cable Grips, Labels
AQ963005	4S/2M ABS Relay Valve Kit for Tri-Axles	N9002AB	6-Port, 1/2" Res. Port 12V, 3/8" Control 3/8" Delivery	6.0m Power Cord Extension 2.0m & 3.0m Sensor Extensions 2-Port Relay Valve 2.0m Valve Relay Cable Hose Clips, Cable Grips, Labels
AQ963013	4S/2M FFABS Valve Kit for Tri-Axles	N9002BA	4-Port, 3/4" Nipple 12V, 3/8" Ports Spring Brake Priority	20x12 Power Cord 1.5m & 2.5m Sensor Extensions 2-Port Relay Valve 2.0m Relay Valve Cable Warning Lamp Kit Misc. Hardware & Labels
AQ963014	4S/2M FFABS Valve Kit for Tandem Axles	N9002BE	2-Port, 3/4" Nipple 12V, 3/8" Ports Spring Brake Priority	20x12 Power Cord 2.0m & 2.5m Sensor Extensions 2-Port Relay Valve 2.0m Relay Valve Cable Warning Lamp Kit Misc. Hardware & Labels

ECU Upgrade Kits



Typical – AQ964111 Shown

Features:

- Wheel-speed Sensor and Trailer Power connects directly to ECU – no intermediate cables required
- Single fastener design assures easy serviceability
- Potted ECU Enclosure provides excellent protection from the environment

Specifications:

PLC Select 1M and 2M Kits are available to upgrade earlier generation ECU platforms

Notes:

- 1) Upgrade to new technology PLC Select 1M or 2M – see below for details.
- 2) Most ABS maintenance involves Wheel-end Sensors. Haldex recommends that Wheel-end Sensors be replaced when replacing or upgrading the ABS system.

SKU#	Product Description	ECU Design	Kit Contents	OEM Part Number
AQ960502	2S/1M A8 ECU Upgrade Kit	PLC Select	2.0m Power Cord Extension 3.0m Sensor Extensions PLC Select ECU & Bracket Power Cord End Kit	SN2605B
AQ964110	2S/1M A7 ECU Upgrade Kit	PLC Select	1.0m Power Cord Extension 0.5m Sensor Extensions PLC Select ECU & Bracket	SN2641TC
AQ964111	4S/2M ECU Upgrade Kit	2M PLC Select	2.0m Power Cord Extension 1.0m Sensor Extensions PLC Select 2M ECU & Bracket Power Cord End Kit Valve Relay Cable	SN2632AA

ABS Valves**Solenoid Kit**

SKU#	Product Description	Application	Notes	OEM Part Number
AQ40525	Trailer ABS Solenoid Kit	12 Volts, 24mm Electrical Connector	Includes New Mounting Hardware, Check Ball, DIN Solenoid and Adapter Cable.	RN10JV

ABS Valves

FFABS 2 & 4-Port Delivery



AL430670 Shown

Features:

- Patented FFABS Valve with integral Spring Brake Control function
- Pre-installed Reservoir Nipple with swivel and lock-nut feature assures easy serviceability
- FFABS Valves are standard with filters in both the Control and Supply Ports
- Production part number is embossed on metal tag

Specifications:

- 2-Port ABS Valve** Single Axle Application (either 2S/1M or 4S/2M)
- 4-Port ABS Valve** Multiple Axle Application (2S/1M) and 3 or more Axles (4S/2M)

Notes:

- 1) ECU and bracket may need to be transferred from existing valve.
- 2) Black exhaust cover is Service Brake Priority. Gray exhaust cover is Spring Brake Priority.
- 3) Post Nov. 09 SKU# shipped with Adapter Cable for pre-Din ECU.

SKU#	Product Description	Valve Specifications	OEM Part Number
AL430614	FFABS Valve	4-Port, 1/2" & 3/4" Nipple, 12V, 3/8" Ports Service Brake Priority	N4306CD
AL430620	FFABS Valve	4-Port, 1/2" Nipple, 24V, 3/8" Ports Service Brake Priority	N4306HA
AL430624	FFABS Valve	4-Port, 1/2" & 3/4" Nipple, 12V, 3/8" Ports Spring Brake Priority	N4306BD
AL430644	FFABS Valve	2-Port, 1/2" & 3/4" Nipple, 12V, 3/8" Ports Service Brake Priority	N4306DD
AL430664	FFABS Valve	2-Port, 1/2" & 3/4" Nipple, 12V, 3/8" Ports Spring Brake Priority	N4306FD
AL430666	FFABS Valve	4-Port, 1/2" & 3/4" Nipple, 12V, 3/8" Ports Spring Brake Priority (4-SB Port)	N4306JD
AL430668	FFABS Valve	4-Port, 1/2" & 3/4" Nipple, 12V, 3/8" Ports Service Brake Priority (4-SB Port)	N4306KD
AL430670	FFABS Valve	2-Port, 1/2" & 3/4" Nipple, 12V, 3/8" Ports Spring Brake Priority (4-SB Port)	N4306LD
AL430672	FFABS Valve	2-Port, 1/2" & 3/4" Nipple, 12V, 3/8" Ports Service Brake Priority (4-SB Port)	N4306MD

ABS Valves

ABS Relay 2 & 6-Port Delivery



AL364040 Shown

Features:

- Production part number is embossed on metal tag.

Specifications:

2-Port ABS Valve	Single Axle Application (either 2S/1M or 4S/2M)
6-Port ABS Valve	Multiple Axle Application (2S/1M) and 3 or more Axles (4S/2M)

Notes:

- 1) Frame mount valve may be used in both applications by re-positioning cover.
- 2) ECU and bracket may need to be transferred from existing valve.
- 3) Post Nov. 09 SKU# shipped with Adapter Cable for pre-DIN ECU.

SKU#	Product Description	Valve Specifications	OEM Part Number
AL364040	ABS Relay Valve	2-Port, 1/2" Res. Mount 12V, 3/8" Ports	364140112
AL364041	ABS Relay Valve	6-Port, 1/2" Res. Mount 12V, 3/8" Ports	364141112
AL364045	ABS Relay Valve	2-Port, 1/2" Frame Mount 12V, 3/8" Ports	364140111
AL364046	ABS Relay Valve	6-Port, 1/2" Frame Mount 12V, 3/8" Ports	364141111
AL364080	ABS Relay Valve	2-Port, 1/2" Res. Mount 24V, 3/8" Ports	364318001

ABS ECUs

PLC Select 1M and 2M



AL919339 Shown

Features:

- Wheel-speed Sensor and Trailer Power connects directly to ECU – no intermediate cables required
- Single fastener design assures easy serviceability
- Potted ECU Enclosure provides excellent protection from the environment

Specifications:

- PLC Select 1M** supports all 2S/1M applications
PLC Select 2M supports all 4S/2M (or 2S/2M) applications

Notes:

- 1) PLC Select 1M and 2M Kits are available to upgrade earlier generation ECU platforms.
- 2) Post October 09 SKU# incorporates DIN style Solenoid Cable.
- 3) Post October 09 SKU# shipped with Adapter Cable for pre-DIN ABS Valve and hardware items for 1M ECU's.

SKU#	Product Description	ECU Specifications	Dimensions	Application	OEM Part Number
AL919336	PLC Select Plus ECU	DIN 12V, SLH-A7	4-1/4" Height x 8" Width	Multi-Axle	202028BA
AL919338	PLC Select 1M ECU	DIN 12V, SLH-A7	4-1/4" Height x 5-1/2" Width	Multi-Axle (Non-Steer Axles)	201200AA
AL919339	PLC Select 1M ECU	DIN 12V, SLH-A8	4-1/4" Height x 5-1/2" Width	Dollies and Single Axle	201200AB
AL919340	PLC Select 1M ECU	DIN 12V, SLH-A7	4-1/4" Height x 5-1/2" Width with longer Valve Cable Lead	Multi-Axle (Non-Steer Axle)	201200AC
AL919341	PLC Select 1M ECU	DIN 12V, SLH-A8	4-1/4" Height x 5-1/2" Width with longer Valve Cable Lead	Dollies and Single Axle	201200AD
AL919342	PLC Select 2M ECU	DIN 12V, SLH-A7	4-1/4" Height x 8" Width	Multi-Axle	202028AA

ABS ECUs

PLC/PLC Plus



Features:

- OEM part number is located on top of ECU

Specifications:

- SLH-A8 ECU** Single and Dolly Axles Application
SLH-A7 ECU Multi-Axle (Non-Steer Axles) Application

Notes:

- 1) PLC Select 1M and 2M Kits are available to upgrade earlier generation ECU platforms.
- 2) **PLC Plus platform discontinued – UPGRADE TO NEW TECHNOLOGY.**
 AQ964110 replacement for AL919310
 AQ964111 replacement for AL919316

SKU#	Product Description	ECU Specifications	Dimensions	OEM Part Number
AL919311	ABS PLC ECU	SLH-A7, 19 Pin 2 Keys – Diagonal	3-1/2" Height x 5-3/8" Width	201193DA
AL919312	ABS PLC ECU	SLH-A8, 19 Pin 2 Keys – Across	3-1/2" Height x 5-3/8" Width	201193DB

Power Cords

Full Power Cables



Features:

- Over-mold design introduced 3Q2009
- All Full Power Cables include ABS Lamp Lead
- All Full Power Cables may be shortened to fit application by cutting the "stripped end"

Specifications:

ECU end	includes over-molded industry 5-Pin female Connector
Trailer Power end	is stripped wires

Notes:

- 1) Pre-2001 models discontinued.

SKU#	Product Description	Length	ABS Lamp Lead	Application	OEM Part Number
AL918602	Trailer ABS Full Power Cable	65.7 ft. (20m)	39.4 ft. (12m)	For production March 2001 to present	201186RD
AL918603	Trailer ABS Full Power Cable	39.4 ft. (12m)	26.2 ft. (8m)	For production March 2001 to present	201186RA
AL918604	Trailer ABS Full Power Cable	52.5 ft. (16m)	26.2 ft. (8m)	For production March 2001 to present	201186RB
AL918605	Trailer ABS Full Power Cable	59.1 ft. (18m)	39.4 ft. (12m)	For production March 2001 to present	201186RC
AL918606	Trailer ABS Full Power Cable	16 ft. (5m)	10 ft. (3m)	For production March 2001 to present	201186RG

Power Cords

Power Cord Extensions



Features:

- Over-mold design introduced 3Q2009

Specifications:

ECU end	includes over-molded industry 5-Pin female Connector
Trailer Power end	includes over-molded industry 5-Pin male Connector

Notes:

- 1) Use Power Cord Extension when Trailer Power Cable is too short to reach the ECU 5-pin Connector.
- 2) Haldex PLC Select ECU platform design permits elimination of a Power Cord Extension.

AL919903 Shown

SKU#	Product Description	Length	OEM Part Number
AL301220	Multi-System Lamp Junction Y-Cable (4S/2M 2S/1M = 6S/3M)	-	300122HC
AL919900	Trailer ABS Power Cord Extension	6.6 ft. (2m)	201199PB
AL919901	Trailer ABS Power Cord Extension	13.1 ft. (4m)	201199PD
AL919902	Trailer ABS Power Cord Extension	19.7 ft. (6m)	201199PF
AL919903	Trailer ABS Power Cord Extension	3.0 ft. (1m)	201199PA
AL919904	Trailer ABS Power Cord Extension	1.0 ft. (.3m)	201199PG

Looms



Typical – AL40900 Shown

Features:

- **AL40900-906** OEM assembly number is located on tag on existing loom.

Specifications:

- ECU end** has a 19 Pin or 28 Pin Connector that interfaces with matching connector on the ECU (insure both sides are locked in place to assure constant electrical signal and proper ABS performance)
- Trailer end includes** **Sensor Leads** (2 or 4 depending on ABS configuration), **Valve Leads** (1 or 2 depending on ABS configuration), **Power Lead** with industry 5-Pin male Connector

Notes:

- 1) For longer Power Cord Adapters, use Power Cord Extensions.
- 2) **PLC Plus platform discontinued – UPGRADE TO NEW TECHNOLOGY (ECU Upgrade Kits).**
 AQ964110 replaces AL40953, AL40957
 AQ964111 replaces AL956100, AL956104, AL956108

SKU#	Product Description	Power Cord Length	Specifications	Application	OEM Part Number
AL40900	2S1M PLC Loom Assembly	1.5 ft. (0.5m)	SLH-A7, 19 Pin 2 Keys – Diagonal	Production from March 2001 to Present	409000A
AL40901	2S1M PLC Loom Assembly	1.5 ft. (0.5m)	SLH-A8, 19 Pin 2 Keys – Across	Production from March 2001 to Present	409000AA
AL40906	4S2M PLC Loom Assembly	1.5 ft. (0.5m)	19 Pin, No Keys	Production from March 2001 to Present	409000CA

Sensors



Features:

- Sensors supplied with **A59512309** (OEM #059512309) Retainer Clip

Specifications:

Haldex Sensors use only Haldex Sensor Retainer Clips

Notes:

- 1) Longer lengths may be used; secure excess to trailer.
- 2) Production cables are identified with a tape applied OE part number.
- 3) Referenced OEM Part Numbers **do not** include Sensor Retainer Clip (AL59512309/059512309).

SKU#	Product Description	Length	OEM Part Number
AL10271914	ABS 90° Sensor Body with Clip	1.6 ft. (0.5m)	364094001 See notes about referenced OEM Part Numbers
AL10271915	ABS 90° Sensor Body with Clip	6.6 ft. (2m)	364094061 See notes about referenced OEM Part Numbers
AL1027196	ABS Straight Body Sensor with Clip	1.6 ft. (0.5m)	364528001 See notes about referenced OEM Part Numbers
AL1027197	ABS Straight Body Sensor with Clip	6.6 ft. (2m)	364528011 See notes about referenced OEM Part Numbers
AL1027198	ABS Straight Body Sensor with Clip	13.1 ft. (4m)	364528051 See notes about referenced OEM Part Numbers
AL364053	ABS 90° Sensor Body with Clip	13.1 ft. (4m)	364094111 See notes about referenced OEM Part Numbers
AL364061	ABS 90° Sensor Body with Clip	4.9 ft. (1.5m)	364094041 See notes about referenced OEM Part Numbers
AL364062	ABS 90° Sensor Body with Clip	8.2 ft. (2.5m)	364094081 See notes about referenced OEM Part Numbers
AL364063	ABS 90° Sensor Body with Clip	11.5 ft. (3.5m)	364094101 See notes about referenced OEM Part Numbers
AL364068	ABS 90° Sensor Body with Clip	4.0 ft. (1.25m)	364094121 See notes about referenced OEM Part Numbers
AL364069	ABS 90° Sensor Body with Clip	5.0 ft. (1.75m)	364094051 See notes about referenced OEM Part Numbers
AL364070	ABS 90° Sensor Body with Clip	7.0 ft. (2.25m)	364094071 See notes about referenced OEM Part Numbers
AL364071	ABS 90° Sensor Body with Clip	9.0 ft. (3m)	364094091 See notes about referenced OEM Part Numbers
AQ40213	ABS 90° Sensor Kit with Clip and Block	6.6 ft. (2m)	SN4021TB

Sensor Extensions

Universal Sensor Extensions



Features:

- Use universally with any Haldex Sensor or Sensor Extension to accommodate required length
- Use in conjunction with 0.5m Sensors to interface with the ECU (or Loom) connections OR with the longer Sensors to gain additional length in special applications

Specifications:

ECU end	has 2-Pin female Connector
Sensor end	has 2-Pin male Connector

Notes:

- 1) Longer lengths may be used; secure excess to trailer.

SKU#	Product Description	Length	OEM Part Number
AL919800	ABS Extension for Sensor Cable Lead	1.6 ft. (0.5m)	201198BA
AL919801	ABS Extension for Sensor Cable Lead	3.3 ft. (1m)	201198BB
AL919802	ABS Extension for Sensor Cable Lead	4.9 ft. (1.5m)	201198BC
AL919803	ABS Extension for Sensor Cable Lead	6.6 ft. (2m)	201198BD
AL919804	ABS Extension for Sensor Cable Lead	8.2 ft. (2.5m)	201198BE
AL919805	ABS Extension for Sensor Cable Lead	9.8 ft. (3m)	201198BF
AL919806	ABS Extension for Sensor Cable Lead	11.5 ft. (3.5m)	201198BG
AL919807	ABS Extension for Sensor Cable Lead	13.1 ft. (4m)	201198BH
AL919808	ABS Extension for Sensor Cable Lead	16.4 ft. (5m)	201198BJ
AL919809	ABS Extension for Sensor Cable Lead	19.7 ft. (6m)	201198BK
AL919810	ABS Extension for Sensor Cable Lead	26.2 ft. (8m)	201198BL
AL919811	ABS Extension for Sensor Cable Lead	32.8 ft. (10m)	201198BM

ABS Adapter Cables – DIN and pre-DIN Systems

SKU#	Product Description	Length
AL919346	ABS Adapter Cable – pre-DIN ECU to DIN Solenoid	6"
AL919347	ABS Adapter Cable – DIN ECU to pre-DIN Solenoid	6"

ABS Valve Cable Extensions – DIN and pre-DIN Systems



Specifications:

- Cable Female End** has 3-Pin female Connector (DIN or pre-DIN)
- Cable Male End** has 3-Pin male Connector (DIN or pre-DIN)

Notes:

- 1) Longer lengths may be used; secure excess to trailer.



SKU#	Product Description	Length	OEM Part Number
AL919812	Trailer ABS Extension for ABS Valve Cable – pre-DIN Systems	3.0 ft. (1m)	201198CA
AL919813	Trailer ABS Extension for ABS Valve Cable – pre-DIN Systems	6.0 ft. (2m)	201198CB
AL919814	Trailer ABS Extension for ABS Valve Cable – pre-DIN Systems	9.0 ft. (3m)	201198CC
AL919815	Trailer ABS Extension for ABS Valve Cable – pre-DIN Systems	12.0 ft. (4m)	201198CD
AL919816	Trailer ABS Extension for ABS Valve Cable – pre-DIN Systems	19.0 ft. (6m)	201198CE
AL919817	Trailer ABS Extension for ABS Valve Cable – pre-DIN Systems	25.0 ft. (8m)	201198CF
AL919818	Trailer ABS Extension for ABS Valve Cable – pre-DIN Systems	31.0 ft. (10m)	201198CG
AL919819	Trailer ABS Extension for ABS Valve Cable – DIN Systems	3.3 ft. (1m)	364543001
AL919820	Trailer ABS Extension for ABS Valve Cable – DIN Systems	6.6 ft. (2m)	364543011
AL919821	Trailer ABS Extension for ABS Valve Cable – DIN Systems	13.2 ft. (4m)	364543021
AL919822	Trailer ABS Extension for ABS Valve Cable – DIN Systems	26.4 ft. (8m)	364543031
AL919823	Trailer ABS Extension for ABS Valve Cable – DIN Systems	33.0 ft. (10m)	364543041

PLC Select 2M and PLC Select Plus Remote Valve Cable – DIN and pre-DIN Systems



Features:

- Provides variable cable lengths for PLC Select 2M remote ABS Valve Solenoid

Specifications:

ECU end weather tight, click-fit Connector
Valve Solenoid end has 3-Pin female Connector (DIN or pre-DIN)

Notes:

- 1) To gain additional length for special applications use Valve Cable Extensions such as **AL919812**.
- 2) **UPGRADE TO NEW TECHNOLOGY PLC Select 1M or 2M BY CONTACTING A HALDEX REPRESENTATIVE FOR APPLICATION ASSISTANCE.**

SKU#	Product Description	Application/Notes	OEM Part Number
AL929812	PLC Select 2M and PLC Select Plus Remote ABS Valve Cable – pre-DIN Systems	3.0 ft. (1m) Length	364501001
AL929813	PLC Select 2M and PLC Select Plus Remote ABS Valve Cable – pre-DIN Systems	15.0 ft. (5m) Length	364501021
AL929814	PLC Select 2M and PLC Select Plus Remote ABS Valve Cable – pre-DIN Systems	6.0 ft. (2m) Length	364501011
AL929815	PLC Select 2M and PLC Select Plus Remote ABS Valve Cable – pre-DIN Systems	27.0 ft. (9m) Length	364501031
AL929818	PLC Select 2M and PLC Select Plus Remote ABS Valve Cable – DIN Systems	3.3 ft. (1m) Length	364533001
AL929819	PLC Select 2M and PLC Select Plus Remote ABS Valve Cable – DIN Systems	6.6 ft. (2m) Length	364533011
AL929820	PLC Select 2M and PLC Select Plus Remote ABS Valve Cable – DIN Systems	16.5 ft. (5m) Length	364533021
AL929821	PLC Select 2M and PLC Select Plus Remote ABS Valve Cable – DIN Systems	29.7 ft. (9m) Length	364533031

PLC Select Plus Auxiliary Interface Cables



AL929817 Shown

SKU#	Product Description	Length	Application	OEM Part Number
AL929816	PLC Select Plus Auxiliary Interface Cable	2.0m	ECU Output to Auxiliary Control Device	364530001
AL929817	PLC Select Plus Auxiliary Interface Cable	18.0m	ECU Input – 7 Way	814001311
AL929822	PLC Select Plus Auxiliary Interface Cable	3.3 ft. 1.0m	–	201199SA
AL929823	PLC Select Plus Auxiliary Interface Cable	13.2 ft. 4.0m	–	364533031

Trailer Roll Stability (TRS) Applications



Typical – AL919337 ECU and
AL833000 Valve Shown

Features:

- 4S/2M ABS with Roll Stability Support
- ECU and Dual Modulator Valve Serviced Separately
- Integral Lateral Accelerometer to monitor Roll Stability
- Integral Control Line Filter

Specifications:

Material Made of EGC material for light weight, durability and environmental protection

Ports NPT

Sensors Works with standard ABS Wheel Speed Sensors

Notes:

- 1) Requires Air Suspension.
- 2) TRS system uses a separate Spring Brake Control Valve such as the Haldex **N34031** Series.
- 3) Retrofit Kits Available (see below).
- 4) **TRS improves Rollover Stability while the Driver remains vital in the safe operation of the vehicle including avoiding Rollover!**

SKU#	Product Description	Application/Notes	OEM Part #
042689109	TRS Fleet CD – Version 2.4	Use with AQ15853 for TRS Operational Data	042689109
815012011	TRS Remote Accelerometer	Used for installations where centered mounting isn't available.	815012011
A993108	TRS Label	TRS Weld Warning Label	600384G
AL364429	TRS Info Center	July 2005 to Present Production 12V, American Standard Units for TRS	835002001
AL833000	TRS Dual Modulator Valve	Reservoir Port 1/2", Control Port 3/8" Air Bag Port 3/8", 6-Delivery Ports 3/8"	833002001
AL919337	TRS ECU	12V with 3 Auxiliary Ports	832002001S
AL956112	TRS Sensor Extension	10 Ft. (3.0m) Length with Click-fit, Sealed Connector	814004401
AL956113	TRS Diagnostic Cable	July 2005 to Present Production Side of Trailer Bracket Mount for TRS Tools	814010101
AL956114	TRS Sensor Extension	20 Ft. (6.0m) Length with Click-fit, Sealed Connector	814004411
AL956115	TRS Sensor Extension	6.5 Ft. (2.0m) Length with Click-fit, Sealed Connector	814004421
AL956116	TRS Power Cord Extension Basic (without Brake Light Illumination benefit)	Provides Delphi 5-Pin N.A. Power Convention	834005001
AQ15853	TRS Diag PC Diagnostic Kit	12V, CD, Interface Cabling (PC not included)	835004001
AQ968302	TRS Premium Retrofit Kit	12V, TRS Components for Retrofit of existing 4S/2M ABS Installations	SN2633C
AQ968303	TRS Service Kit (Gen 2 for Gen 1)	Service Components for Gen 1 ECU (AL919329 / 832001001) & PLC Power Adapter (AL95691 / 300569AD)	SN2633E
AQ968304	TRS Replacement Kit (Heil Special)	TRS Components for Retrofit of existing 4S/2M ABS Installations	SN2633AA

Labels & Decals



A993108 Shown

SKU#	Product Description	Application/Notes	OEM Part Number
A993107	Indicator Lamp Decal for PLC	Post March 2001 Production	101931ZZ
A993108	TRS Label	TRS Weld Warning Label	600384G

Diagnostics & Displays

Electronic Odometer



Features:

- Value-added alternative to mechanical Hubodometer
- At the Press of a Button:
 - Access Trailer Odometer Reading
 - Access and/or Reset Trip Mileage
 - Read Active Diagnostic Code
- Sensor Test capability with vehicle power

Specifications:

- | | |
|------------------------------------|--------------------------------------------------|
| Improved accuracy | over mechanical solutions |
| On-board, long life battery | enables most functionality without vehicle power |
| Designed | for mounting to the nose of the trailer |
| EGP Cover | adds protection and a level of data privacy |
| Data stored in the ABS ECU | that adds security from data tampering |

Notes:

- 1) Operating instructions included in Aftermarket Kit.

SKU#	Product Description	Cable	OEM Part Number
AQ15491	PLC Trailer ABS E-Odometer Kit – Nose Mounted	2.0m	364435001
L30038	E-Odometer Instruction Manual	-	L30038

Diagnostics & Displays

ABS PC Diagnostic Kits (PC not included)



AQ15853 Shown

SKU#	Product Description	Application/Notes	OEM Part #
042689109	TRS Fleet CD – Version 2.4	Use with AQ15853 for TRS Operational Data	042689109
815012011	TRS Remote Accelerometer	Used for installations where centered mounting isn't available.	815012011
AL2030012	Tractor Power Outlet Adapter	Haldex PLC System Adapter	203001B
AL230010	7 Way Diagnostic Interface Cable	Haldex PLC System Adapter	203001
AL955804	Trailer ABS PLC Interface Cable	Haldex PLC/PC Diagnostic Program, March 2001 to Present	300558B
AL956113	TRS Diagnostic Cable	July 2005 to Present Production Side of Trailer Bracket Mount for TRS Tools	814010101
AQ158410	Alligator Clip Adapter	Haldex PLC System Adapter	SN158DK
AQ15853	TRS Diag PC Diagnostic Kit	12V, CD, Interface Cabling (PC not included)	835004001
AQ15854	PLC Trailer ABS PC Diagnostic (USB) Kit	Haldex PLC/PC Diagnostic Program, March 2001 to Present Minimum CPU requirements Pentium II with 32 MB RAM 233 MHZ Processor Windows 95B or NT4.0 (PC not included)	SN158DM

Installation Components & Accessories

ABS Trailer Lights & Components



AQ15463



A920805



A1017316

SKU#	Product Description	OEM Part Number
A1017316	Trailer ABS Round Indicator Lamp	101731F
A920805	Bracket for Round Trailer ABS Lamp	102008HP
AQ15463	Trailer ABS Lamp Kit (Bracket, Lamp and 6" Lead)	SN154FC

Installation Components & Accessories

ECU/Valve Brackets & Loom Clasps



A920808



A920811



A920813

Damage to ECU/Valve Brackets may indicate damage to other ABS components that should be diagnosed before changing the Bracket.

SKU#	Product Description	Application/Notes	OEM Part Number
A155000	Trailer ABS PLC ECU Clasp	19 Pin Interface	015504909
A920808	Trailer ABS ECU Mounting Bracket with Screws	19 and 28 Pin Interface	300245AB
A920811	Trailer ABS PLC Select ECU Mounting Bracket	For PLC Select Only	015505209
A920813	Trailer ABS PLC Select 2M ECU Mounting Bracket	For PLC Select 2M Only Bracket with Hardware	015506209

Installation Components & Accessories

Sensor Accessories/Blocks & Exciter Ring



SKU#	Product Description	Measurements	Notes	Application	OEM Part Number
A2020109	Trailer ABS Exciter Ring	100 Tooth	Std. Pack: 1	–	202010J
A902700	Tractor and Trailer ABS Retainer	–	Std. Pack: 4	Sensor Cable to Lead	102700C
A902701	Tractor and Trailer ABS Clip	–	For 1/2" I.D. Hose Std. Pack: 4	Sensor Cable to Hose	100469F
A902702	Tractor and Trailer ABS Clip	–	For 3/8" I.D. Hose Std. Pack: 4	Sensor Cable to Hose	100469E
A920802	Trailer ABS Sensor Block	1.60" Height	Std. Pack: 1	Trailer Axles	102008WN
AL920809	Tractor and Trailer ABS Sensor Wire Retaining Clip	1.25" Length x 1" Width x 1/2" Diameter	Fits 3/8" or 1/2" Rubber Air Brake Hose Std. Pack: 10	Haldex Sensor to either 3/8" to 1/2" Hose	100469H
AL920810	Tractor and Trailer ABS Sensor Wire Retaining Clip	1.25" Length x 1" Width x 1/2" Diameter	Fits 3/8" or 1/2" Rubber Air Brake Hose Std. Pack: 10	WABCO Sensor to either 3/8" or 1/2" Hose	–

Installation Components & Accessories

Miscellaneous ABS Components



A906960



AQ15457



AQ15458



AQ15473



AQ15474



AQ961110

SKU#	Product Description	Application/Notes	OEM Part Number
A906960	ABS Filter	3/8" Port	100696AG
AQ15457	MBS2 WNC Wheel-end Upgrade Kit	Exciter Rings, Sensor Blocks and Hardware Items	SN154EG
AQ15458	MBS2 WNC Wheel-end Upgrade Kit	Exciter Rings, Sensor Brackets and Hardware Items	SN154EH
AQ15473	5 Way Terminal Kit for Power Cords	Power Cord	SN154GC
AQ15474	5 Way Terminal Kit for Loom Assemblies	Loom Assembly	SN154GD
AQ15500	ABS Relay Kit – 12V	Complimentary to PLC Select Plus Dump Axle applications	SN2634
AQ961110	Universal ABS Service Components Kit	Post March 2001 Kit includes: (1) AQ15474 and (1) AQ15473 Power Terminal Kit; (1) AL10271915, (2) AL10271914 and (2) AL1027196 Sensor/Clip Kit; (1) AQ15463 Lamp Kit; (2) AL919803 Extension; (4) A902700 Grip; (10) AL920809 Clip	-

Brake Monitoring System (BMS-1)



Features:

- Operates in conjunction with ABS
- Warns Driver of:
 - Potential Brake Drag
 - Air System Leaks in Emergency Line
 - False Charging of Dolly and Trailer
 - Closed Shut-off Valve

Specifications:

Material	Made of EGC material for light weight, durability and environmental protection
Service Brake Connection	1/4" Tube P-T-C
Spring Brake Connection	1/4" Tube P-T-C
Power In Connection	From Trailer Source
Power Out Connection	To ABS ECU
Mount	Within 0.5m of Trailer Power Source and within 1.0m of ABS ECU

Notes:

- 1) Driver Warning via Audio Alarm
- 2) Service Options:
 - a. Entire Unit
 - b. Lid (Pressure Switches) Service Kit

SKU#	Product Description	Dimension	Application	OEM Part Number
AL95693	Brake Monitoring System (BMS-1)	5.24" Height x 8.10" Width; 7.41" Mounting Hole	ABS Equipped Dollies and Trailers	300569CB