

Haldex

**Installation/
Service Guide**

L30041

Rev. 6 -1/11



PLC Select ABS (2M)

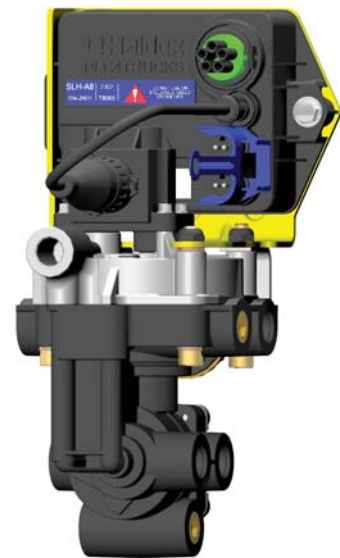

PLC Select ABS (1M)

Installation/Service Manual for
2S/1M - 4S/2M (2S/2M) Systems

\$ 7.00

Technical Service &
Engineering Support

1-800-643-2374 (Press 2)

In Canada, please call

Brake Systems Division
Haldex Limited
500 Pinebush Road, Unit 1
Cambridge, ON
N1T 0A5
Canada

1-800-267-9247

Table of Contents



Section	Page
Table of Contents.....	1
Safety Notice	2
General Operation of PLC Select 1M and 2M	3
Wheel End Installation.....	4-5
Wheel Speed Sensor Installation Configurations 1M and 2M Systems.....	6-11
PLC Select ABS (1M) Installation/Service Manual for 2S/1M Systems.....	12
PLC Select 1M - System Components	13
PLC Select 1M - ECU/Valve Units OverView	14-15
PLC Select 1M and 2M Valve Orientation	16
PLC Select 1M - Installation Overview (4 Port FFABS Systems 2/S1M).....	17
PLC Select 1M - PLC Select FFABS 2S/1M (Plumbing Schematic).....	17
PLC Select 1M - Installation Overview (6 Port ABS System 2S/1M).....	18
PLC Select 1M - PLC Select 6 Port ABS 2S/1M (Plumbing Schematic)	18
PLC Select 1M - ABS Power Cord - Pin Out - 1M ECU OverView	19
PLC Select 1M - 2S/1M System Wiring.....	20
PLC Select 1M - Speed Sensor Cable Routing.....	21-22
PLC Select ABS (2M) Installation/Service Manual for 4S/2M Systems.....	23
PLC Select 2M - System Components	24
PLC Select 2M - ECU/Valve Units Overview.....	25-26
PLC Select 2M - Installation Overview (FFABS System 4S/2M)	27
PLC Select 2M - PLC Select FFABS 4S/2M (Plumbing Schematic) (Side-By-Side).....	27
PLC Select 2M - Installation Overview (ABS Relay System 4S/2M)	28
PLC Select 2M - PLC Select 2 Port ABS 4S/2M (Plumbing Schematic) (Side-By-Side).....	28
PLC Select 2M - PLC Select FFABS 4S/2M (Plumbing Schematic) (Axle-By-Axle).....	29
PLC Select 2M - PLC Select 2 Port ABS 4S/2M (Plumbing Schematic) (Axle-By-Axle).....	30
PLC Select 2M - Full Trailer (Plumbing Schematic) (Axle-By-Axle)	31
PLC Select 2M - PLC Select 2M ECU Overview	32
PLC Select 2M - 4S/2M System Wiring (Side-By-Side)	33
PLC Select 2M - 4S/2M System Wiring (Axle-By-Axle)	34
PLC Select 2M - 4S/2M System Wiring-PLC Select.....	35
PLC Select 2M - Speed Sensor Cable Routing.....	36-37
Testing and Diagnostic Tools:	
PLC Select 1M - 2M Chasis/End of Line Testing.....	38
PLC Select 1M-2M Road Testing.....	39
Diagnostic Tools PLC PC Diagnostic.....	40-42
Diagnostic Tools - Blink Code Diagnostics	43-47
Tire Scale Factor Chart:	
PLC Select 1M - 2M Tire Scale Factor Chart.....	48
PLC Select 1M - 2M Diagnostics:	
PLC Select 1M - 2M Troubleshooting ABS Warning Light.....	49
PLC Select 1M - 2M Diagnostics Codes	50-55



Safety Notice:

This installation manual describes the correct installation procedures for the Haldex PLC Select 1M and 2M for trailers. The PLC Select 1M and 2M may be used with either Drum or Disc Brakes. Care must be taken during each phase of the installation in order to ensure the system is installed correctly.

Safety First !

Please follow your company's safety procedures when you install this equipment. Be sure that you understand all instructions before you begin.

Note: Remove all air pressure and electrical power from the brake system before beginning work.

IMPORTANT NOTICE

*The data listed herein is correct to the best of Haldex's knowledge and belief, having been compiled from reliable and official sources of information. However, **HALDEX CAN NOT ASSUME ANY RESPONSIBILITY** for possible error or misapplication of the product. Final determination of the suitability of the products for the use contemplated by the Buyer is the sole responsibility of the Buyer. Haldex shall have no responsibility in connection with this suitability.*

IMPORTANT NOTICE

The description and specifications contained in this Installation/Service Manual are current at the time of printing. Haldex Brake Products Corp. reserves the right to discontinue or modify its models and/or procedure and to change specifications at any time without notice.

All rights reserved.

Material may only be reproduced with written permission of Haldex.

General Operation of PLC Select 1M and 2M



The Haldex PLC Select 1M and 2M are the newest ECU platforms in the PLC family of Trailer ABS products and is the latest offering in the state-of-art PLC Select concept.

As with other ABS systems, PLC Select 1M and 2M are designed to use electronic management of service braking to avoid wheel lock-up, during all types of braking conditions, and on all road surface conditions, to improve control and stability of a braking trailer to permit air brake compliance with FMVSS 121.

The primary components of Haldex ABS are the ECU (Electronic Control Unit), ABS Modulator Valves (solenoid operated air valves), Wheel Speed Sensor (sensors), and Exciter Rings (exciters).

The inductive sensors are mounted at the designated wheel ends in conjunction with exciter (notched rings). The ECU reads electric impulses generated from the rotating exciter, as the wheels turn.

The ECU is designed to recognize when the rate of wheel speed deceleration is approaching wheel-lock (no longer rotating) which would result in skidding. During a braking event, the ECU continuously monitors the rate of deceleration so that it can automatically intervene into the operation of the ABS Modulator Valve(s) to maintain vehicle stability during braking:

- When the rate of deceleration approaches wheel-lock the ECU sends electrical signals to the ABS Modulator Valve(s) to reduce air pressure to the service brake chambers which reduces braking (to maximize stability);
- When the rate of deceleration returns to a level above the wheel-lock threshold the ECU sends electrical signals to the ABS Modulator Valve(s) to increase pressure to the service brake chambers which increases braking.
- This iterative process of decreasing and increasing braking takes place in milliseconds and continues as long as the deceleration rate is in jeopardy of wheel-lock to help assure vehicle stability.

The Haldex PLC Select 1M is positioned as a 2S/1M system for Semi-Trailers and Dollies using 2 Sensors and 1 Modulator (ABS Valve).

Note: Haldex recommends our 2S/1M A8 product as a more cost effective solution to meet minimum FMVSS121 requirements for Semi-Trailer and Dollies, and in most applications can provide comparable performance as 2M systems.

The Haldex PLC Select 2M is positioned as a 4S/2M system using 4 Sensors and 2 Modulators (ABS Valves). Although it can be used for 2S/2M applications, Haldex recommends our 2S/1M A7 product as comparable performance and more economical.

Although a 4S/2M is only required for Full Trailers to comply with FMVSS 121 it can provide improved performance in certain applications, and we encourage you to consult your Haldex representative for a recommendation to fit your specific application needs and/or preferences. All other braked Semi-Trailer and Dollies comply with FMVSS 121 using a 2S/1M system.

FMVSS 121 specifies that "Blue Wire" (J560 connector Pin no. 7) be allocated as "permanent power" for ABS operation. In the event of a failure or malfunction of the permanent power circuit the ABS system will operate on power from the stoplight circuit (i.e. when the brakes are applied). **If the power fails in both circuits the ABS system reverts to a standard braking system.**



Wheel End Installation

The radial clocking position of the sensor block should be between 9 and 3 o'clock. While the ABS performance is not affected with sensor location in the lower half of the axle, the structural integrity of the axle could be compromised.

Note: The sensor block should not interfere with any wheel end hardware.

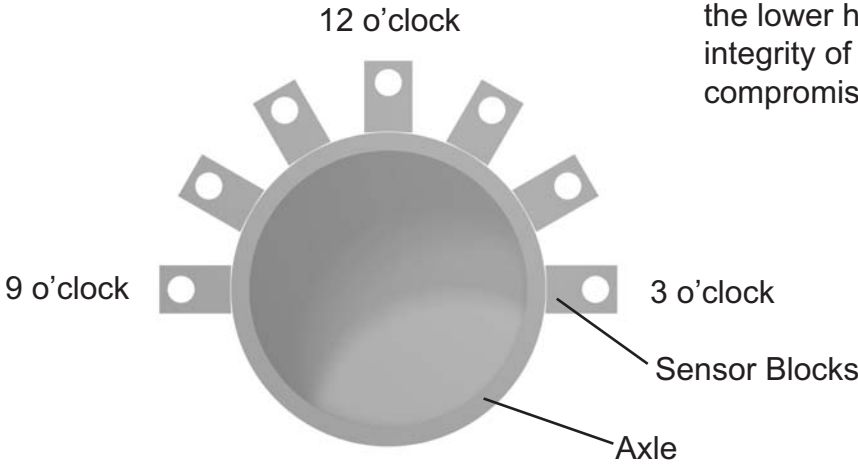

Sensor Block allowable placement

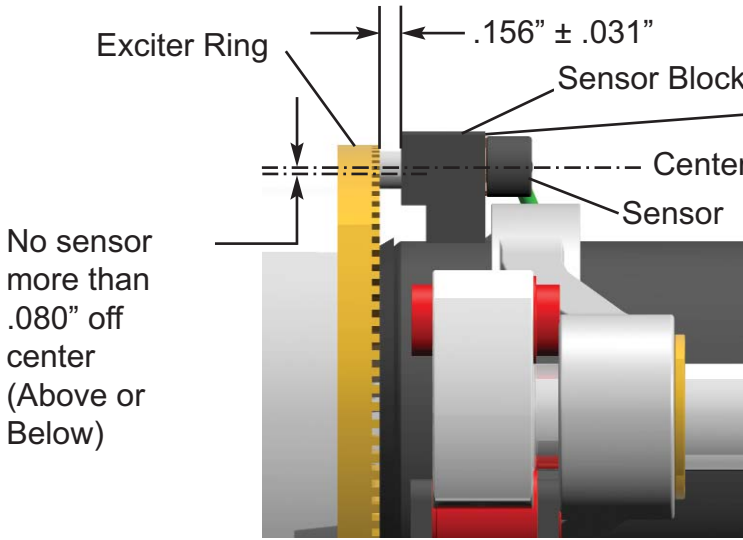

The clearance between the block and exciter ring should be $0.156 \pm .031$ ". Any deviation will result in a reduction of the wheel speed sensor signal output.

In general, the position of the wheel speed sensor center axis to the exciter right surface should be as close as possible to a 90° angle in both direction. Any deviation will result in a reduction of the wheel speed sensor signal output.

Note: The sensor block is generally welded to the axle. Refer to axle manufacturer's manual to ensure that welding won't affect structural integrity.

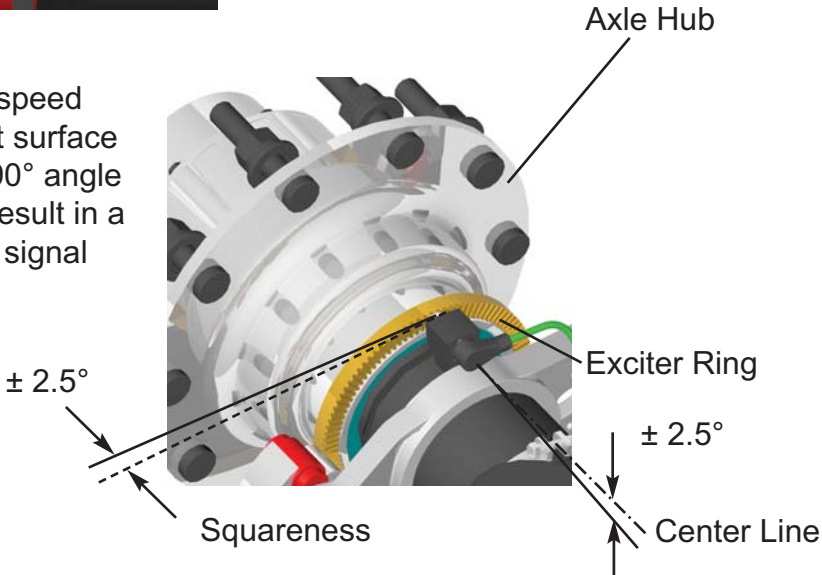



Exciter Ring Installation



Use a wire brush to clean area on hub before mounting the exciter ring.



1. Heat the exciter ring uniformly to approximately 350° F.
2. Place the exciter ring on the machined area of the axle hub.
3. Make sure the exciter ring fits squarely on the machined surface.
4. When the exciter ring cools, it will shrink fit onto the hub.
5. Make sure the exciter ring fits tightly onto the machined area and does not slip.
6. Damage to any teeth on exciter ring may cause a dynamic fault

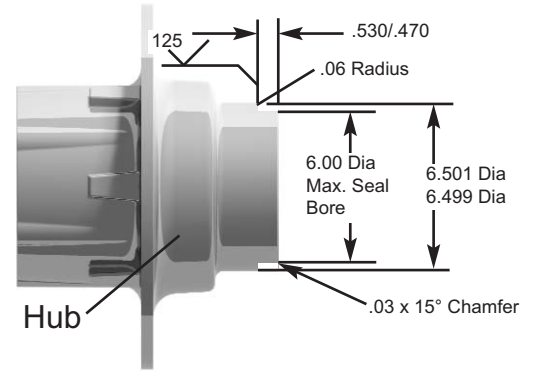
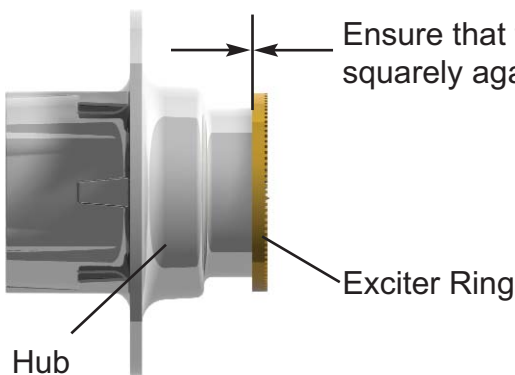

Exciter Ring Machining



Exciter Ring

Note: Some applications with small wheel/tires may require 80 tooth exciters. Reference "Tire Scale Factor Chart" on page 47.



Wheel Speed Sensor Installation 2S/1M Configurations

Sensors should be installed on the axle as shown below is unloaded. Recommended locations are shown below. The 1A sensor should be installed on the curb side, and the 1B sensor should be installed on the road side of the trailer. Make sure sensors are pushed **firmly** against the exciter rings.

Dollies and Single Axle Trailers (2 or 6 Ports Valve)

“For Dollies, Single Axle Trailers, and Steer Axles, Haldex recommends A8 ECU configuration”

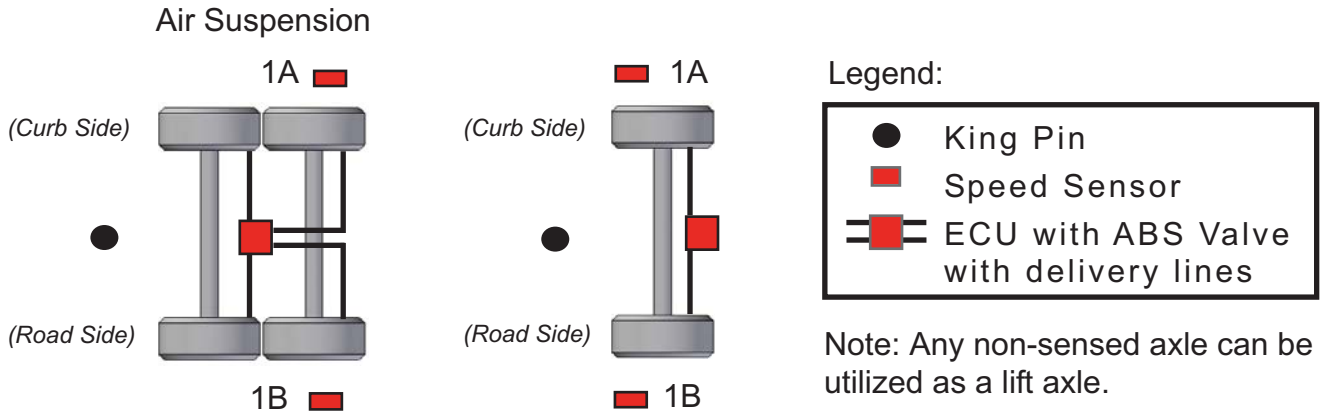

Multi-Axle Trailers (4 or 6 Port Valves) Haldex recommends A7 ECU configuration

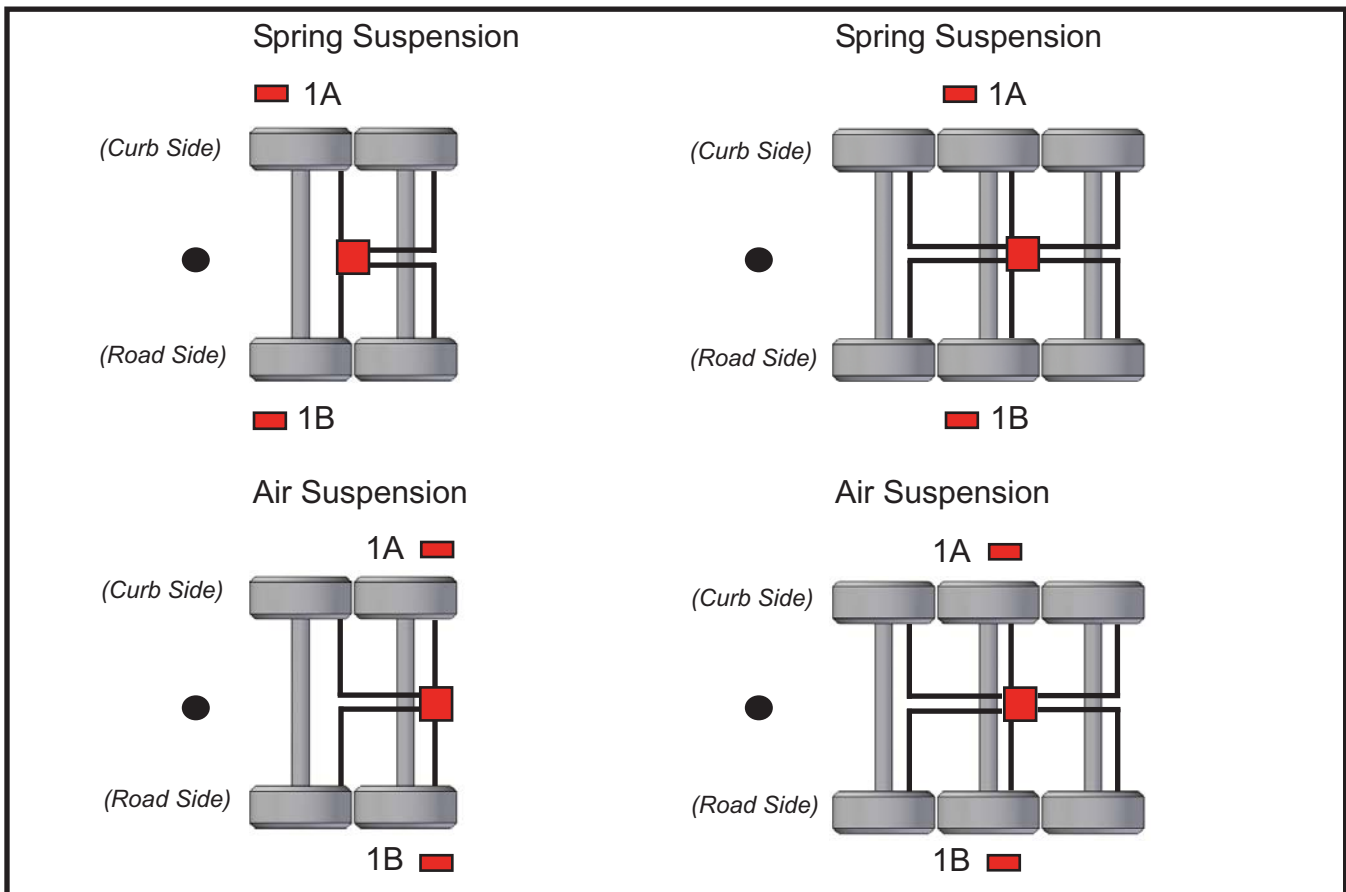

Wheel Speed Sensor Installation 2S/2M Configurations (Side-By-Side)



Sensors should be installed on the axle that locks first when the trailer is unloaded. Recommended locations are shown below. The 2A (blue) sensor should be installed on the curb side, and the 2B (yellow) sensor should be installed on the road side of the trailer. Make sure sensors are pushed **firmly** against the exciter rings. The “yellow markings” sensor connections and axle locations must go to the yellow ABS valve as shown below. The same holds true for the “blue markings” valve. On 2S/2M side by side configurations. The “blue” modulator lead must be connected to the valve that controls the curb side wheel end and are sensed by sensor S2A. The yellow modulator valve cable lead must be connected to the valve that controls the road side wheel end and are sensed by sensor 2B.

Note:

The 2S/2M configuration does not offer any meaningful performance benefit over a 2S/1M SLH-A7 configuration, and is not a preferred system. To obtain additional performance beyond a 2S/1M configuration, Haldex recommends the use of a 4S/2M System

Note:

Any non-sensed axle can be utilized as a lift axle

Legend:

	King Pin
	Speed Sensor
	ABS Valve with delivery lines (Blue Channel)
	ECU with ABS Valve & delivery lines (Yellow Channel)

Multi-Axle Trailers

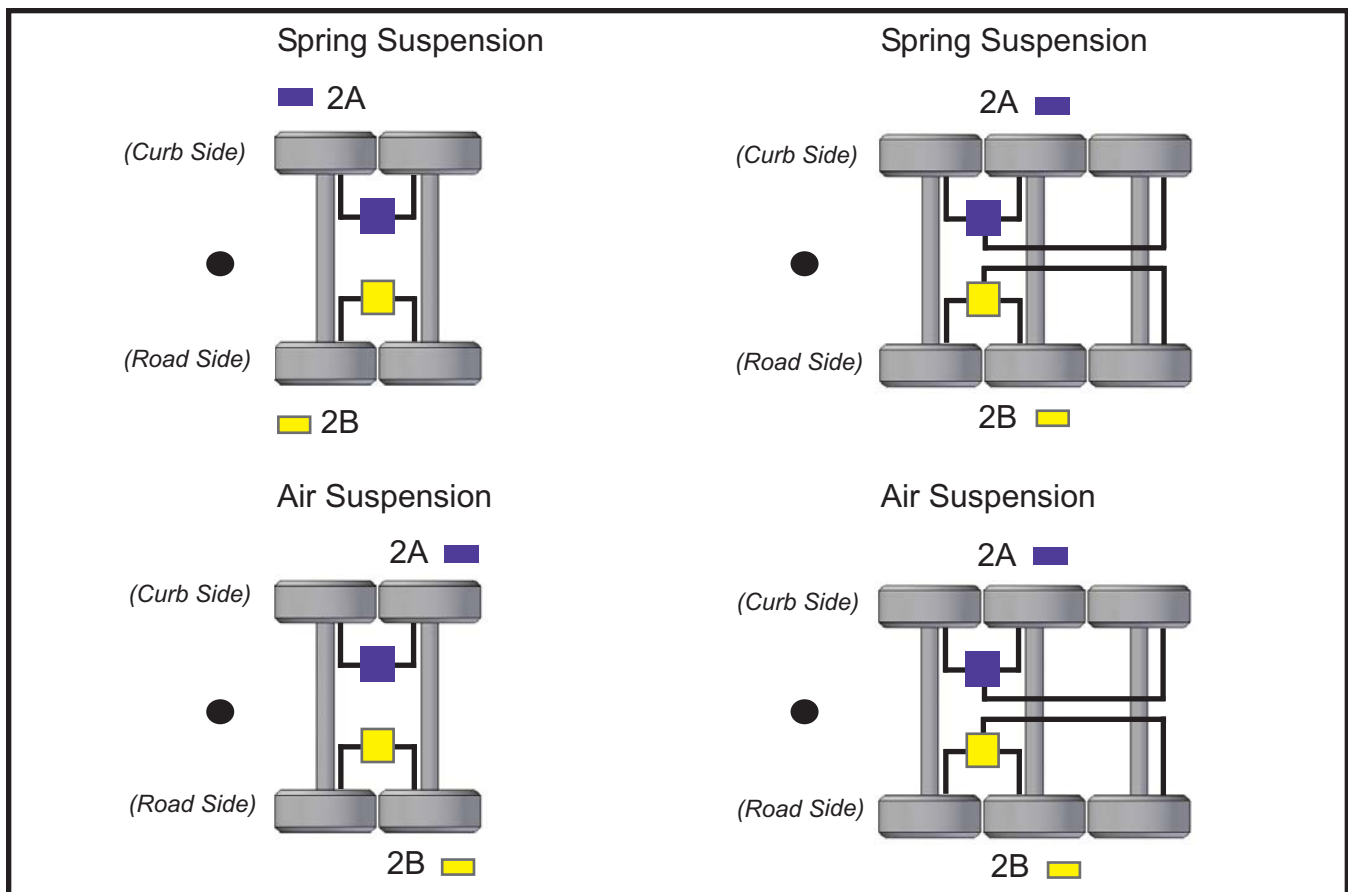



Wheel Speed Sensor Installation 4S/2M Configurations (Side-By-Side)

- The placement of the sensors at the wheel end is an important consideration.
- Incorrect installation of the sensors and exciter will result in poor or no ABS operation and result in fault codes with the ABS warning lamp on.

On a 4S/2M Side-By-Side configuration, the (blue modulator) lead must be connected to the valve that controls the Curb Side wheel ends and are sensed by the blue sensors (3A and 2A). The (yellow valve) cable lead must be connected to the valve that controls the Road Side wheel ends and is sensed by the yellow sensors (3B and 2B).

The schematic below shows the proper placement of the sensors and valve leads (the king pin indicates the front of the trailer). Make sure sensors are pushed **firmly** against the exciter rings.

Note:
Any non-sensed axle can be utilized as a lift axle

Legend:

- King Pin
- Speed Sensor
- ABS Valve with delivery lines (**Blue Channel**)
- ECU with ABS Valve & delivery lines (**Yellow Channel**)

Multi-Axle Trailers

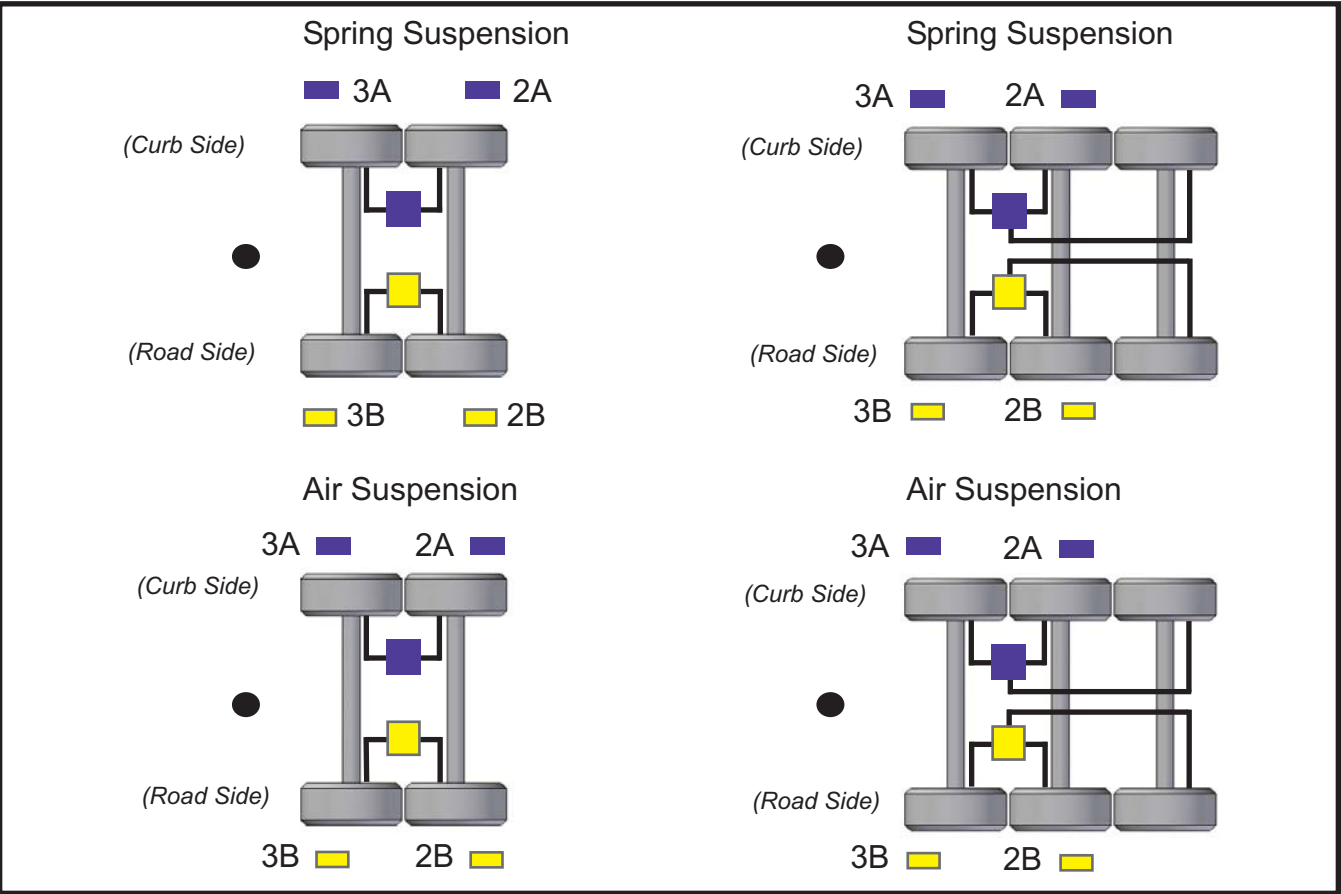

Wheel Speed Sensor Installation 4S/2M (Side-By-Side) Lift Axle Control:



On 4S/2M Side-By-Side installation, the sensed wheels “3A” and “3B” can be used on a lift axle. **The sensed wheels “2A” and “2B” must remain on the ground at all times.**

Note: Axles without sensors, but controlled by ABS valves may be lifted regardless of the configuration. Make sure sensors are pushed **firmly** against the exciter rings.

Direct axle has ABS Sensors. Indirect axle has no sensors but is ABS modulated by an ABS valve.

Legend:

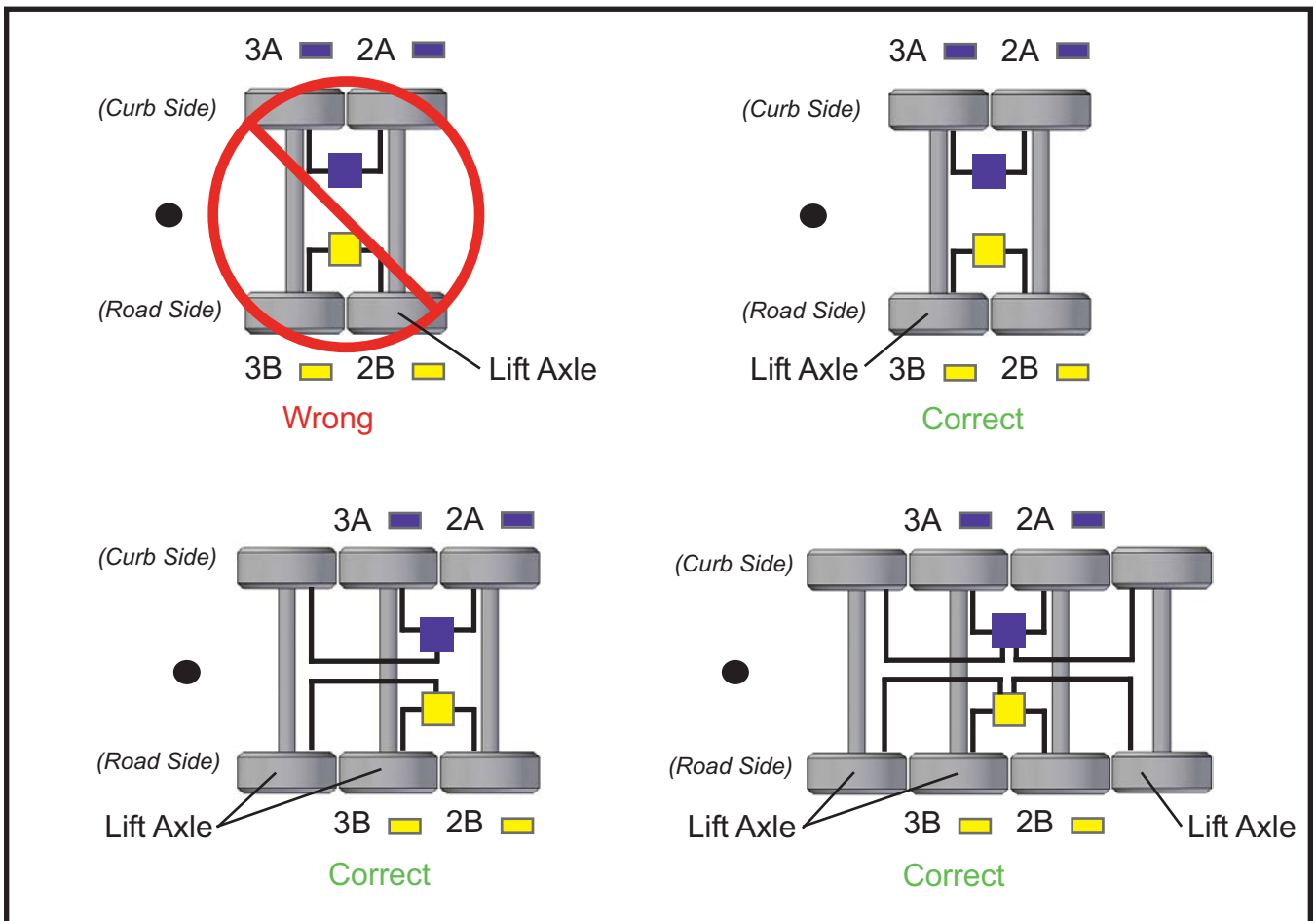
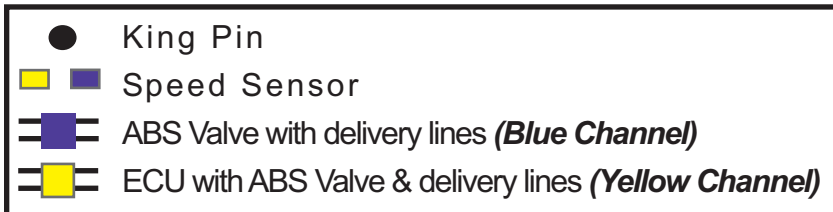



Wheel Speed Sensor Installation 4S/2M Configurations (Axle-By-Axle)

- The placement of the sensors at the wheel end is an important consideration.
- Incorrect installation of the sensors and exciter will result in poor or no ABS operation and result in fault codes with the ABS warning lamp on.

On a 4S/2M Axle-By-Axle configuration, the (blue modulator) lead must be connected to the valve that controls the *Front Axle* wheel ends and is sensed by the blue sensors (3A and 2A). The (yellow valve) cable lead must be connected to the valve that controls the *Rear Axle* wheel ends and is sensed by the yellow sensors (3B and 2B).

The schematic below shows the proper placement of the sensors and valve leads (the king pin indicates the front of the trailer). Make sure sensors are pushed *firmly* against the exciter rings.

Note:

Any non-sensed axle can be utilized as a lift axle

Legend:

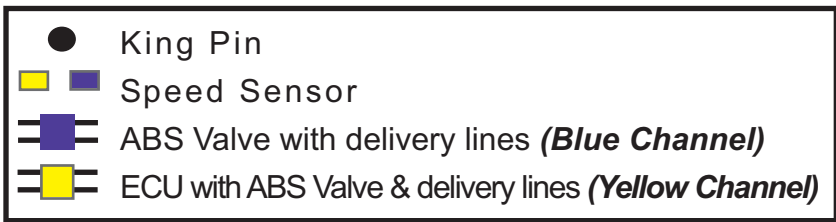

Multi-Axle Trailers

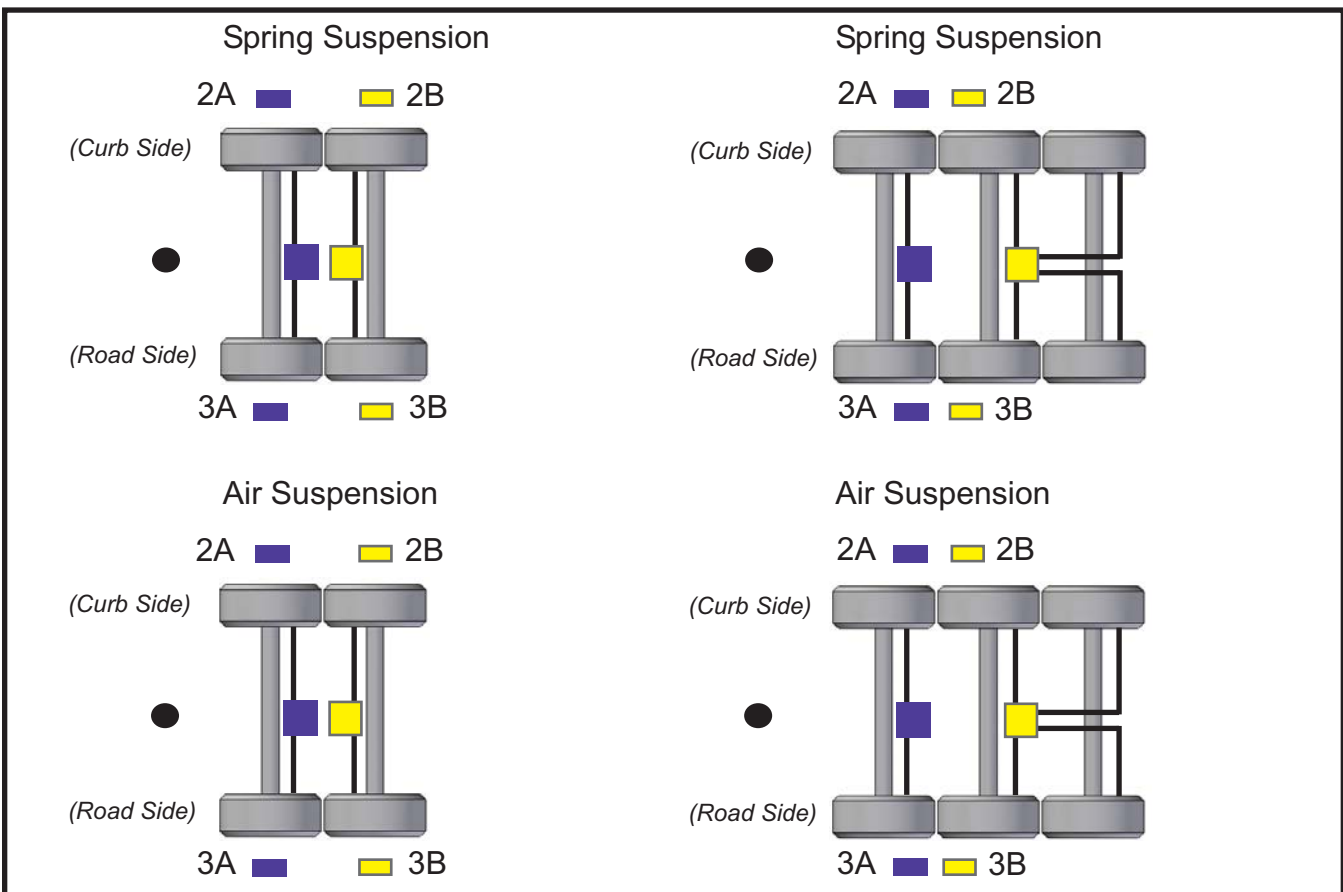

Wheel Speed Sensor Installation

4S/2M (Axle-By-Axle) Lift Axle Control:



On 4S/2M Axle-By-Axle installation, sensed wheels (wheels with ABS sensors) **CAN NOT** be on lift axles. Lifting a sensed axle in this configuration will create an ABS fault. ABS operation will then be suspended until the ABS power has been cycled and all sensed wheels are again rolling on the road surface.

Note:

Any non-sensed axle can be utilized as a lift axle

Legend:

- King Pin
- Speed Sensor
- ABS Valve (**Blue Channel**)
- ECU with ABS Valve (**Yellow Channel**)

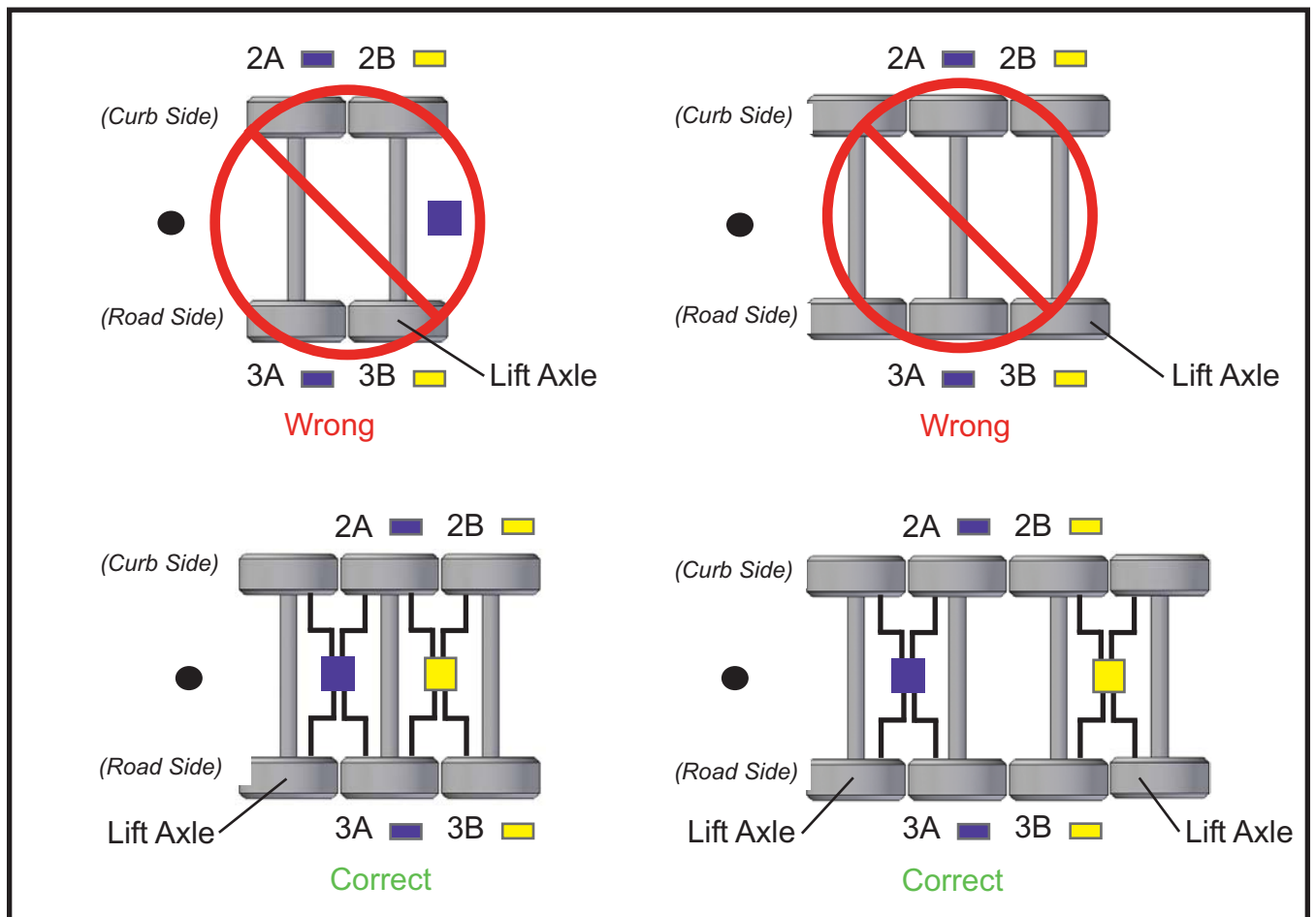

Notes:



Haldex

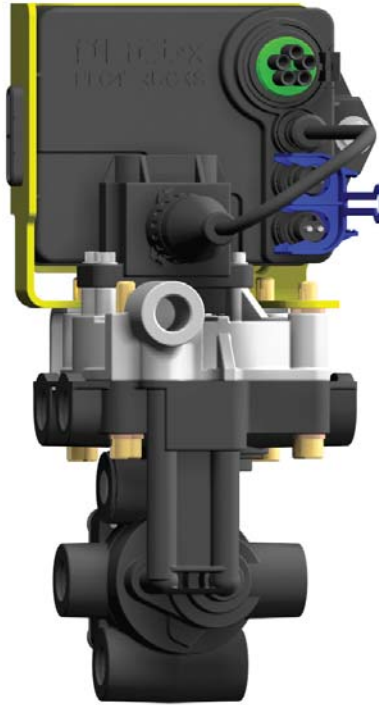

PLC Select ABS (1M)

***Installation/Service Manual
for
2S/1M Systems***



PLC Select 1M System Components

"See Haldex Trailer ABS Service Components Catalog L20243 for additional information on Haldex ABS Products"

Haldex Supplied Items

PLC Select 1M (Valves)

FFABS Valve

2-Port Valve

6-Port Valve

Additional Supplied Items

Trailer Brake Control Valve (Haldex TBCV Shown) (or RT4)

90° Sensor Cable

Trailer ABS Power Cable

Sensor Block Clip

ABS Light

Haldex Diagnostic Tools

7-way Diagnostic Interface Cable

Optional

Software

PLC PC Diagnostics Kit (PC not included)

DLA+/PLC Adapter

PLC Info Center

Recommended Installation Aids

Power Cord Bracket

Sensor Hose Clip

Hole Clamp

Sensor Extension Retainer Clip

Tie Strap



(4 Port) FFABS Valve

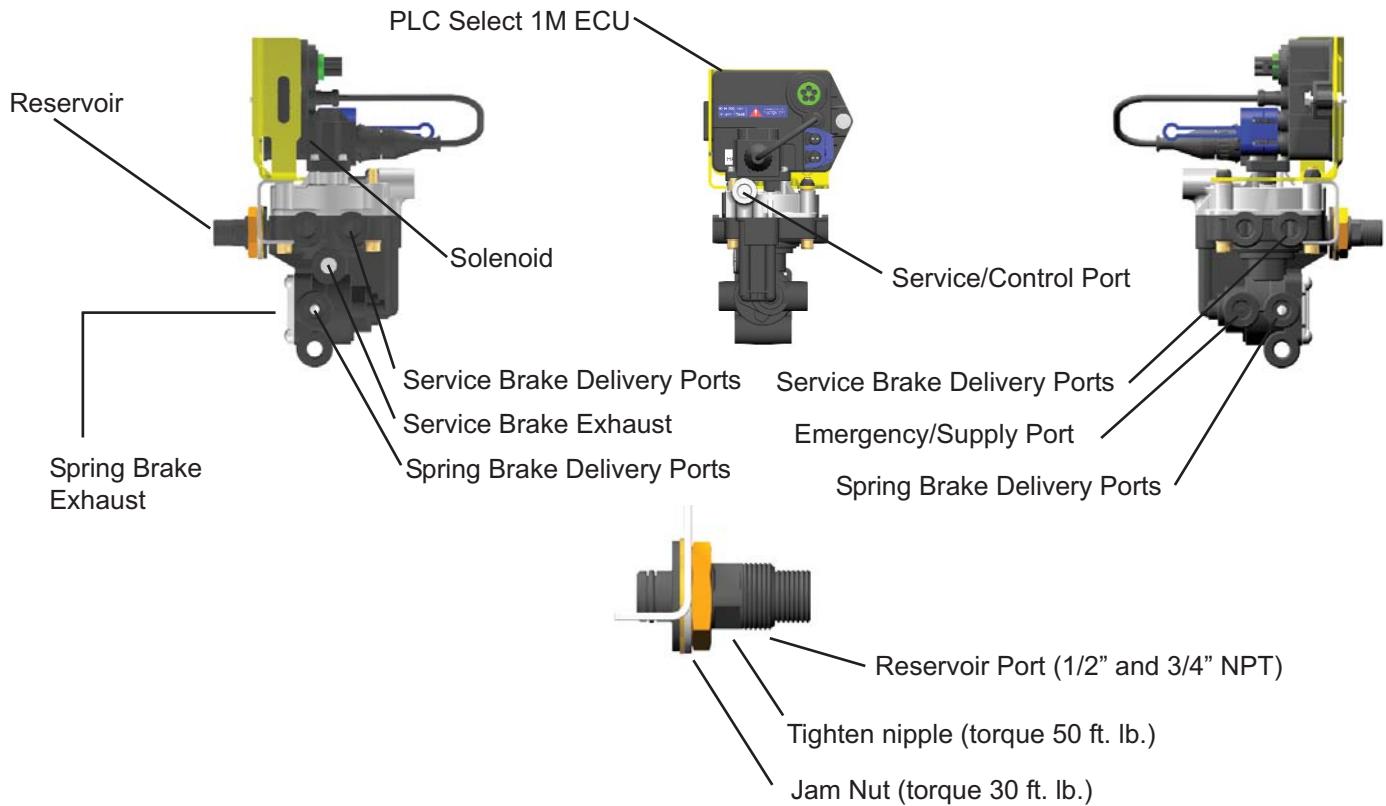

Notes:

- (4) Service Brake Port FFABS Valve is the most commonly used for Tandem Axle Trailers.
- For Single Axle Trailers use (2) Service Brake Port FFABS Valve.
- All ports are 3/8" NPT except reservoir nipple which accommodates either 1/2" or 3/4" NPT Ports.
- Service/Control and Emergency/Supply ports have serviceable Filter/Screen installed.

FFABS Valve Spring Brake Exhaust Cover

- White Indicates Spring Brake Priority
- Black indicates Service Brake Priority



PLC Select 1M ECU/Valve Units Overview

6 Port ABS Relay Valve

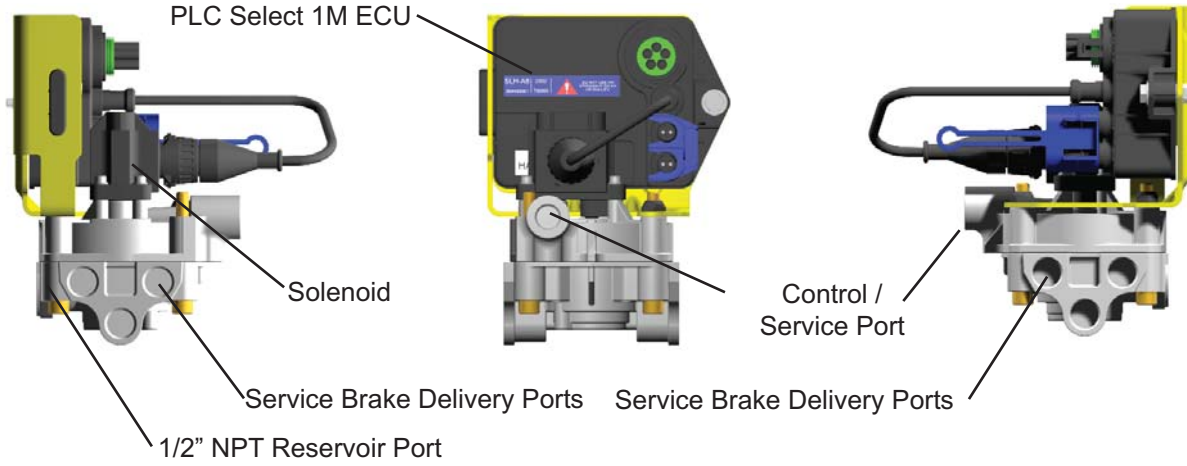

(Requires heavy wall reservoir nipple)

2 Port ABS Relay Valve

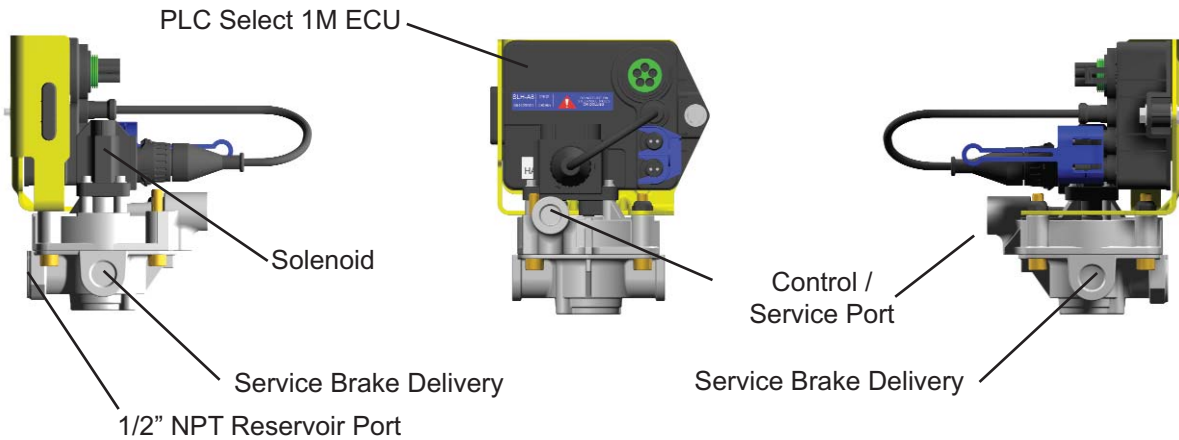

Note: All ports are 3/8" NPT except the reservoir port is 1/2" NPT.

Trailer Brake Control Valve

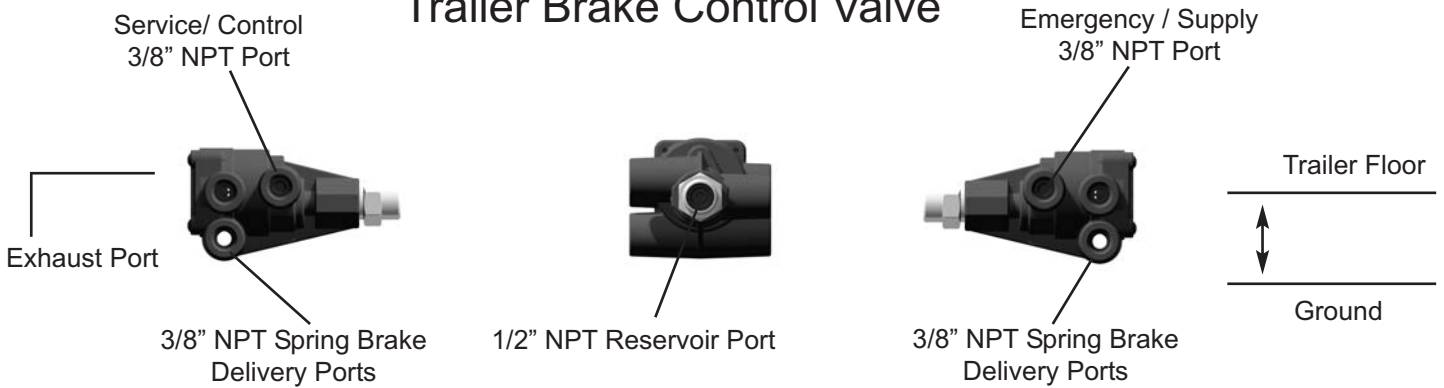

Note:

1. All ports are 3/8" NPT except the reservoir port which is 1/2" NPT.
2. Service/Control and Emergency/Supply ports have serviceable Filter/Screen installed.
3. Install this valve as shown. Exhaust port pointing horizontal.
4. Trailer Brake Control Valve - Exhaust Port - White indicates Spring Brake Priority - Black indicates Service Brake Priority

PLC Select 1M & 2M Valve Orientation



The ABS Valve Solenoid must be installed as shown below

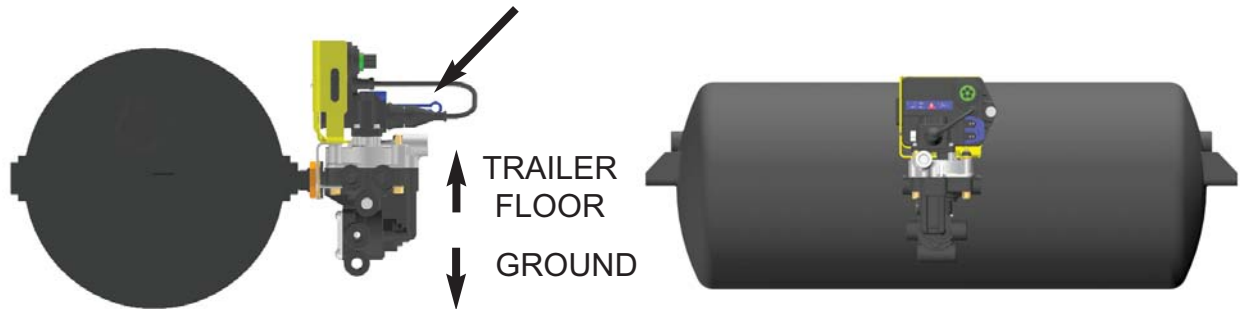

Typical tank mount valve orientation

1. Install fittings into valve. Sealant is not required on plastic threads or on fittings that go into plastic. **DO NOT** use teflon tape on fittings. It can break off and contaminate the air system. Liquid pipe sealant is approved for use if required.
2. For plastic ports, hand tighten fittings then rotate 1 to 1-1/2 additional turns. The maximum torque valve allowed is 210 in-lb.
3. Install valve nipple into reservoir port. Use 7/8" wrench to tighten the nipple.
4. Using a 1-1/2" wrench tighten the jam nut to 30 ft. lb, while holding the nipple with a 7/8" wrench.(see detail below).
5. Attach hoses to appropriate brake chambers. Use liquid thread sealant sparingly on all fittings (Loctite PST565 or equivalent).

Note: *If frame mounted follow same procedure for valve orientation.*

Valve solenoid on a 2-port relay, 6-port relay or FFABS must be facing up when the trailer is in normal operation or service/ABS performance could be effected.

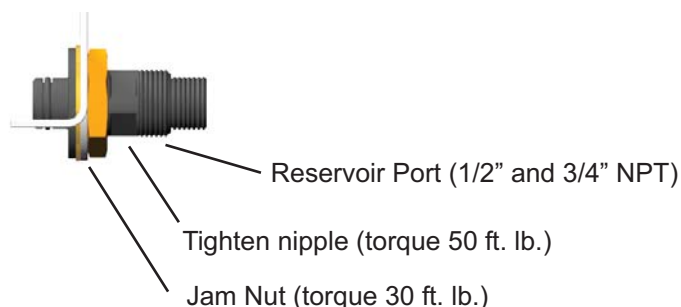

Warning: *Proper installation orientation shown above; otherwise, warranty is void.
Installation behind the tank is recommended, facing the back of the trailer.*



PLC Select FFABS 2S/1M (4 Service Delivery Ports/ 4 Spring Brake Ports)

- Air suspension typically have the sensors on the rear axle
- Spring suspension typically have the sensors on the front axle



PLC Select 1M (FFABS)

Plumbing Schematic (2S/1M) Top View

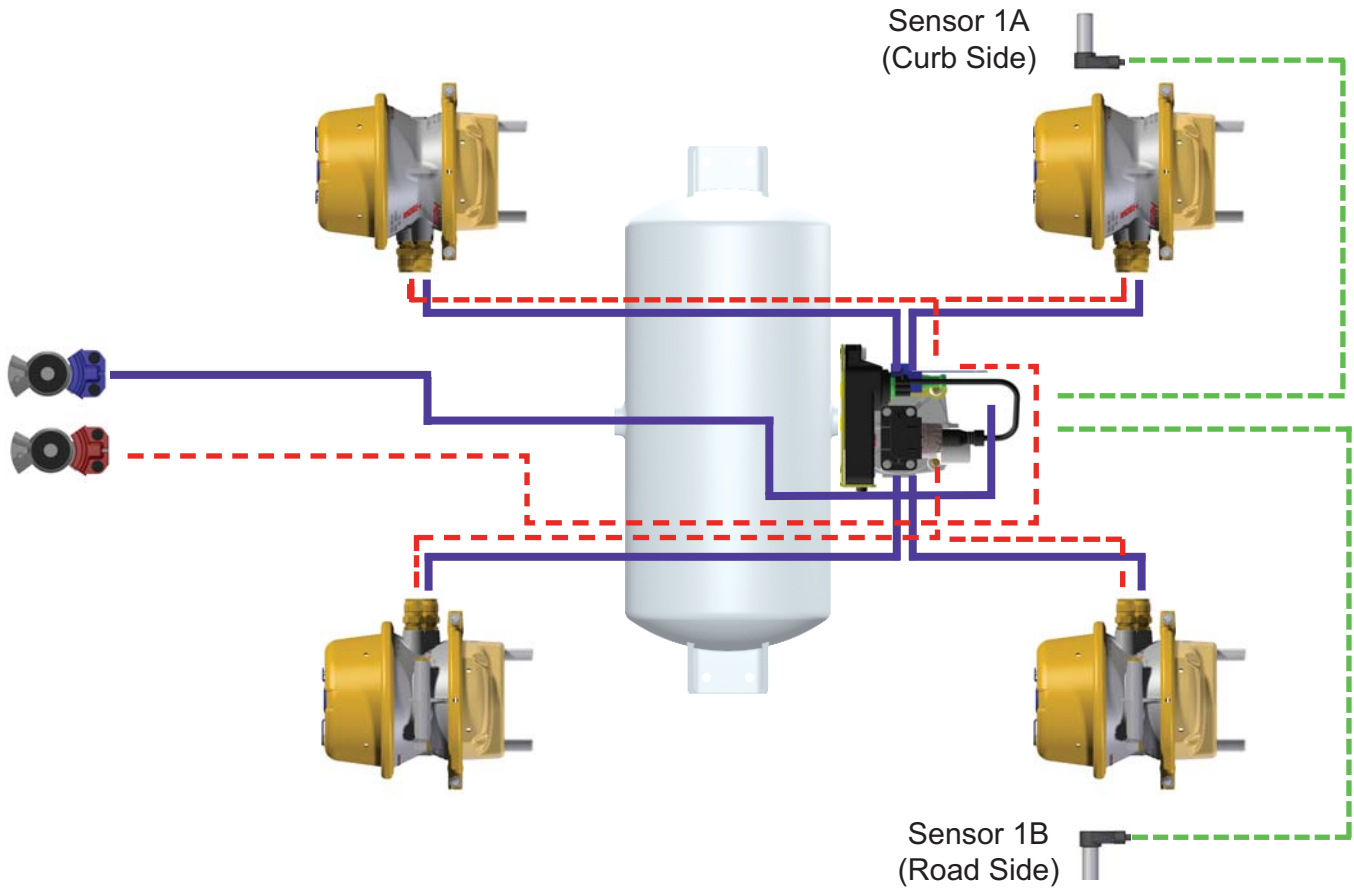

Legend:

Service/Control Line	
Emergency/Supply Line	
Sensor Line	

AIR BRAKE COMPONENTS AND SYSTEM SCHEMATIC ARE DESIGNED TO ALLOW COMPLIANCE WITH FMVSS 121.

THIS SCHEMATIC IS FOR INFORMATION PURPOSE ONLY. IT IS THE VEHICLE MANUFACTURERS ULTIMATE RESPONSIBILITY TO CERTIFY THEIR SYSTEM MEETS ALL APPLICABLE REGULATIONS.

PIPE NIPPLES USED TO MOUNT BRAKE VALVES MUST BE HEAVY WALL TYPE PER SAE J514.

PLC Select 6 Port ABS 2S/1M with Trailer Brake Control Valve



**PLC Select
(6 Port ABS Valve)**

- Air suspension typically sense rear axle
- Spring suspension typically sense front axle



**Trailer Brake Control Valve
(TBCV)**

Plumbing Schematic (2S/1M) Top View

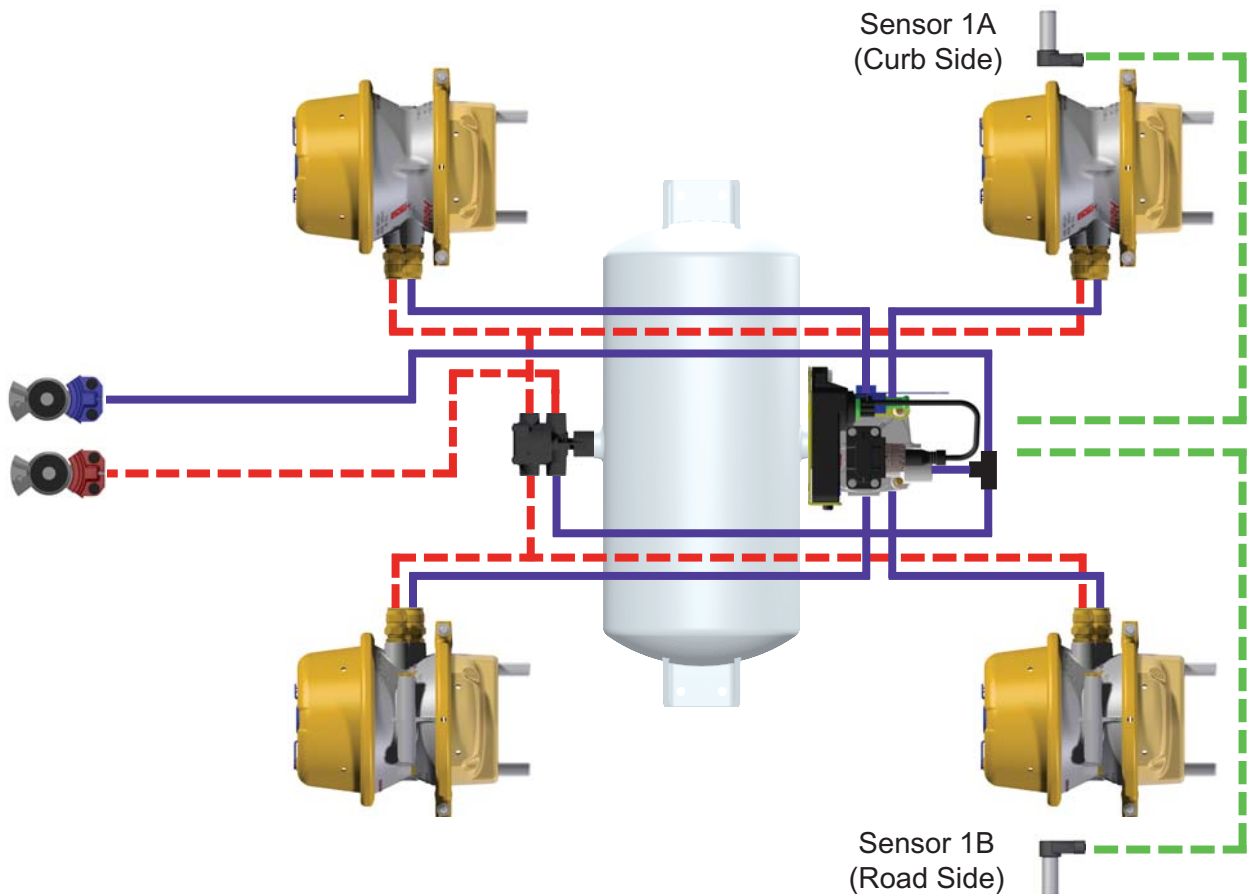

Legend:

Service/Control Line	
Emergency/Supply Line	
Sensor Line	

AIR BRAKE COMPONENTS AND SYSTEM SCHEMATIC ARE DESIGNED TO ALLOW COMPLIANCE WITH FMVSS 121.

THIS SCHEMATIC IS FOR INFORMATION PURPOSE ONLY. IT IS THE VEHICLE MANUFACTURERS ULTIMATE RESPONSIBILITY TO CERTIFY THEIR SYSTEM MEETS ALL APPLICABLE REGULATIONS.

PIPE NIPPLES USED TO MOUNT BRAKE VALVES MUST BE HEAVY WALL TYPE PER SAE J514.



ABS Power Cord - Pin Out

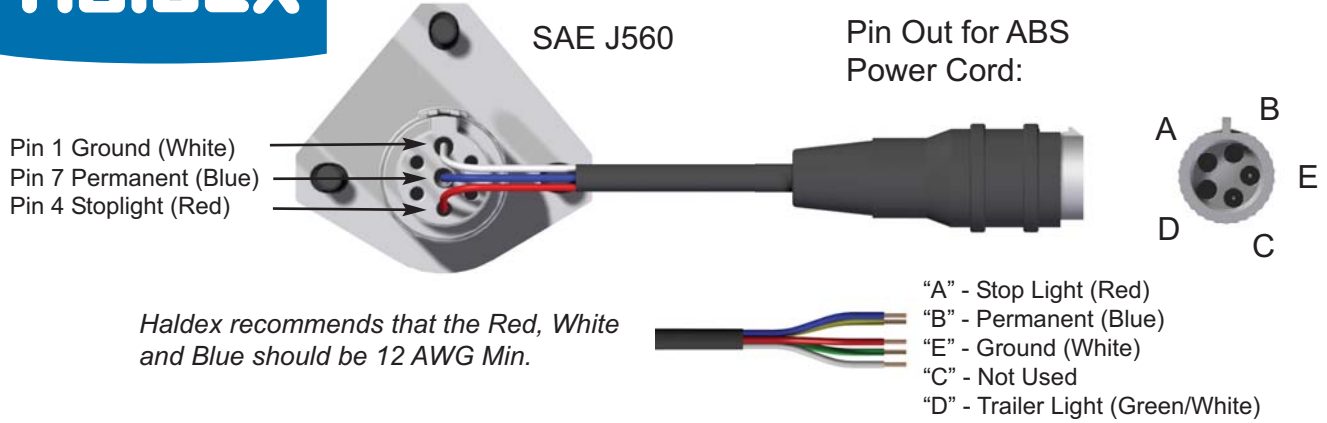

Note: Federal regulations mandate that new trailers, built after 3/1/2001, have the capability to provide an ABS fault signal from the trailer ABS into the tractor for an In-Cab trailer ABS Lamp. Option (1) is through Industry standard "PLC4Trucks" multiplexing (the signal is carried on Pin 7)

PLC Select 1M ECU Overview

Correct location of the speed sensors at the wheel ends is critical for proper ABS operation and troubleshooting. The PLC Select 1M will adjust the braking air pressure in response to the input from the speed sensors. Incorrect installation or location of speed sensors, sensor block clips and exciter rings will result in poor ABS performance or sensors crossed leading to incorrect diagnostics troubleshooting.

The figure below shows the correct power and speed sensor connections on the PLC Select 1M ECU (Electronic Control Unit).

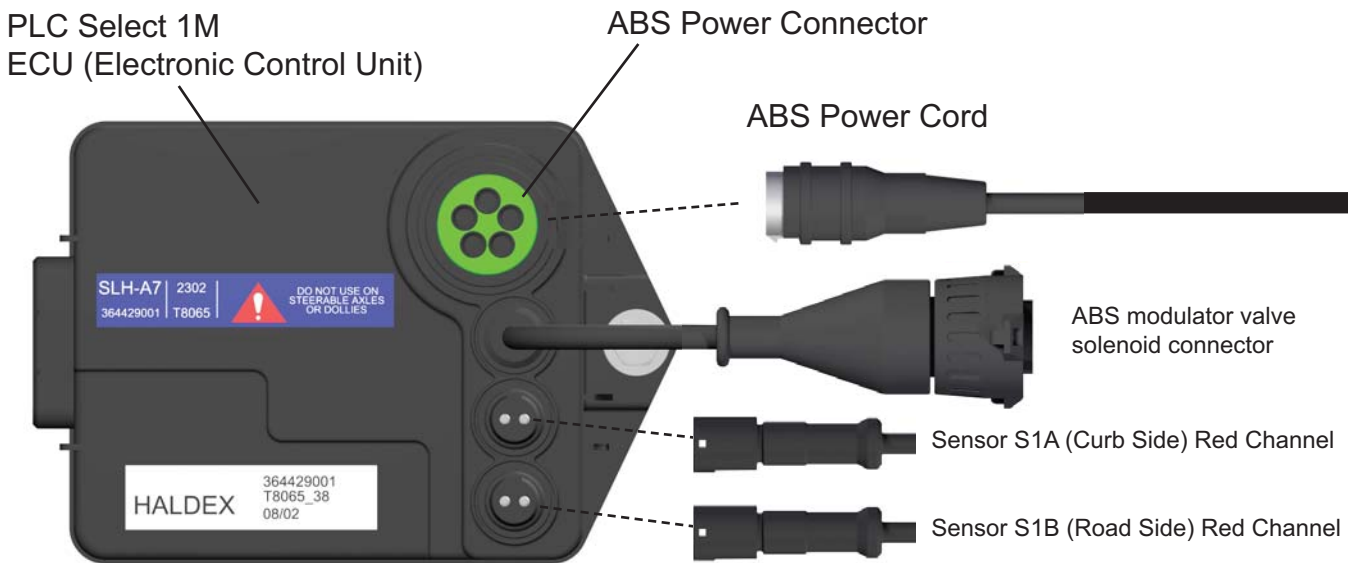

Note: When installing and servicing always apply small amount of dielectric grease to all electrical connections.

2S/1M System Wiring - PLC Select



Note: Cover all exposed electrical connections before painting

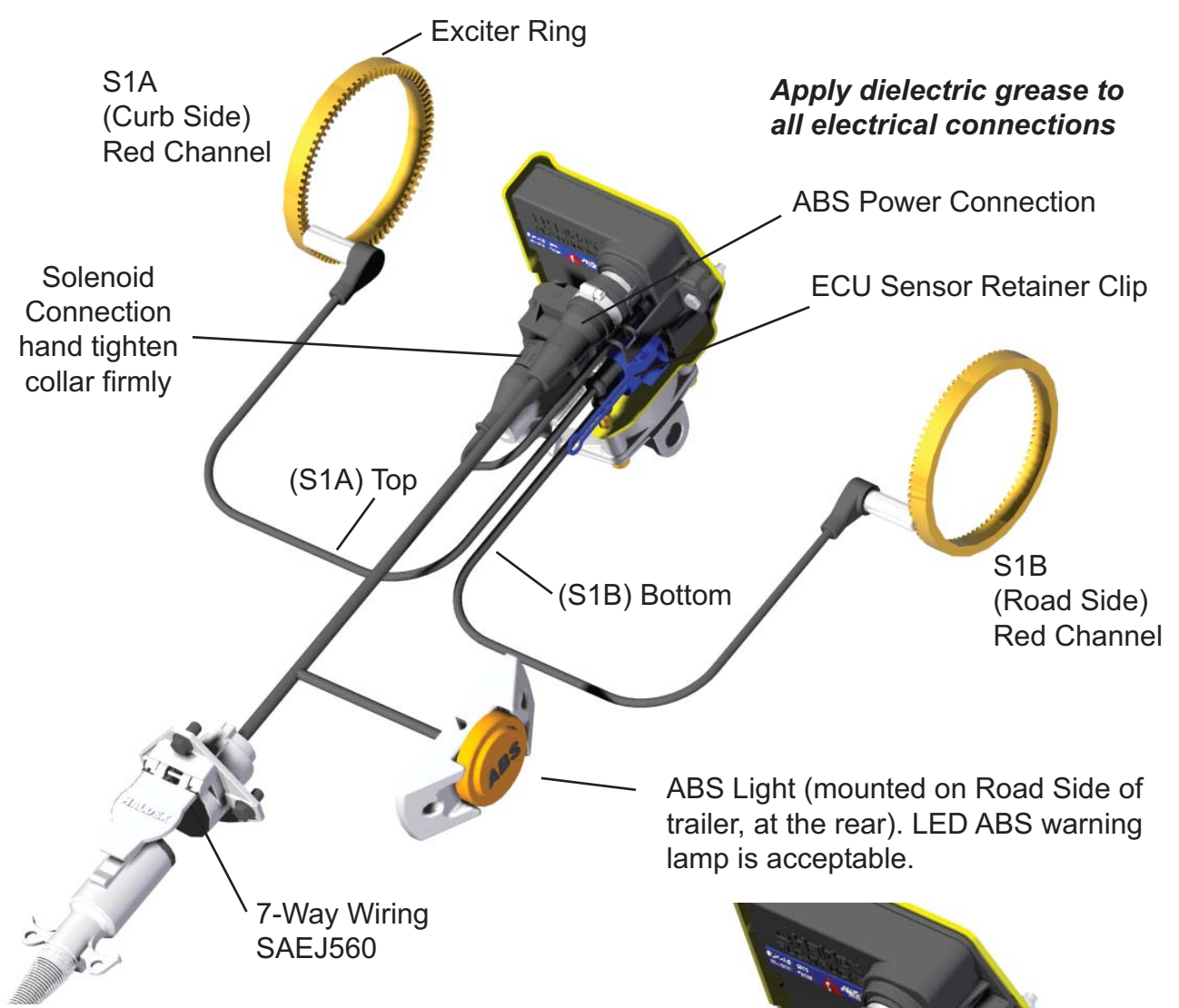

*Distance of ABS Light from Red rear clearance side marker light is 5.9" inches to 23" inches max.

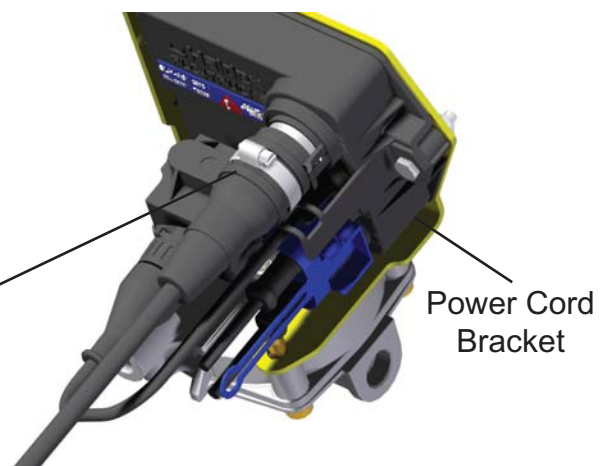

The ABS Power Cord is secured to the power cord bracket (page 13) and is secured with a hose clamp (preferred) or tie strap.

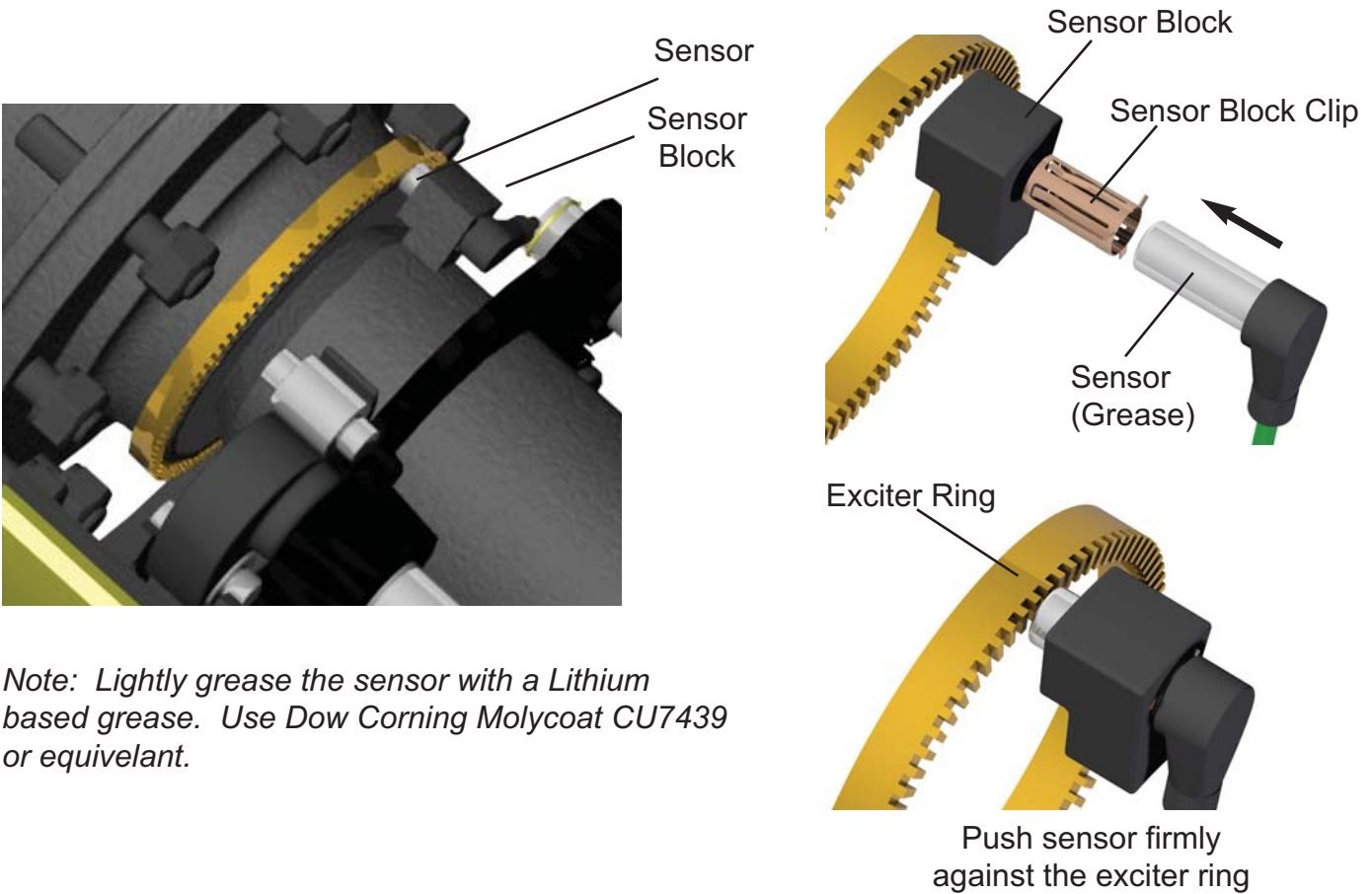

Note: Lightly grease the sensor with a Lithium based grease. Use Dow Corning Molycoat CU7439 or equivalent.

1. Insert the sensor block clip into the sensor block (as shown above).
2. Grease the sensor with a lithium based grease or anti-seize then insert the sensor into the sensor block clip and push until it is firmly against the exciter ring (as shown above).
3. Route all sensor cables through vacant holes, etc. Use a grommet or corrugated tubing if the cables are touching sharp edges.
4. Attach cable ties as needed to ensure the cable is secured to the axle housing.
5. Typical routing of cable is along the brake chamber air hose.
6. Use sensor cable hose clip when attaching the cables to the air hoses.
7. Sensor cable hose clips should be no farther than 8-10" inches apart.

Note: Haldex does not recommend the use of tie straps to secure sensor wires to rubber air hoses. Expansion of rubber air hoses will damage sensor wires causing ABS sensor failure.

Speed Sensor Cable Routing



Although it is possible to route cables along the axle, the preferred approach is to route the speed sensor cables along the air hoses between the ABS valve and the brake actuators.

Tie straps should not be used to secure the speed sensor cable to air hoses. For a more reliable installation use sensor hose clips to secure speed sensor cables to rubber air hoses.

Leave some slack in cables to accommodate movement between chassis components. Excess cable must not be allowed to hang free and must be bundled and attached to the chassis to prevent damage due to vibration and abrasion.

Route sensor wire on backside of axle housing to avoid damage from road debris.

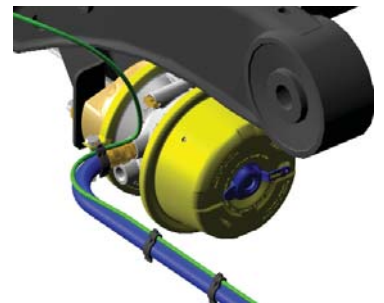
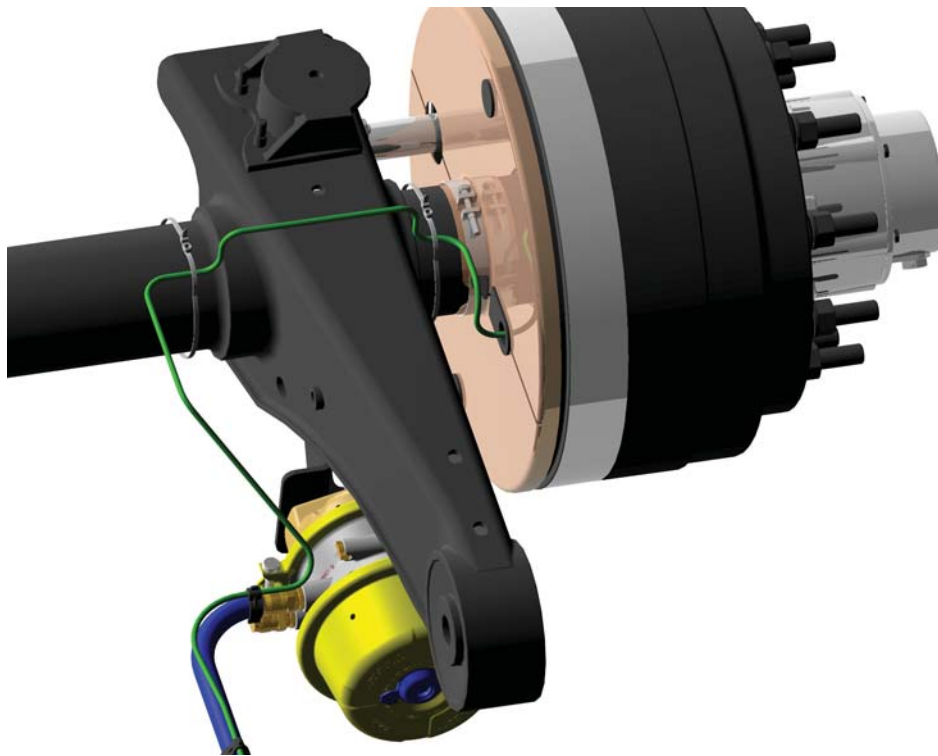

A sensor hose clip is placed on the hose and sensor wire.



Sensor Hose Clip

Excess cable length may be taken up in either a “short bone” or a “long bone” arrangement and secured with tie straps. Do not coil the cable into a loop smaller than 4 inches in diameter. Do not over tighten the tie straps when the cable is coiled, as this could cause a cable failure.



Push up and and attach tie straps.



Long cable (long bone)



Short Cable (short bone)

Haldex

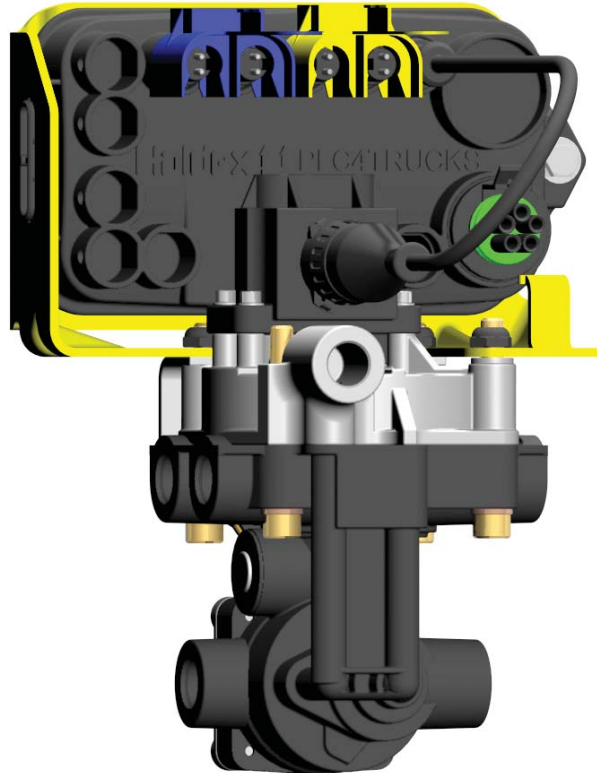

PLC Select ABS (2M)

***Installation/Service Manual
for
4S/2M (2S/2M) Systems***



PLC Select 2M System Components

“See Haldex Trailer ABS Service Components Catalog L20243 for additional information on Haldex ABS Products”

Haldex Supplied Items

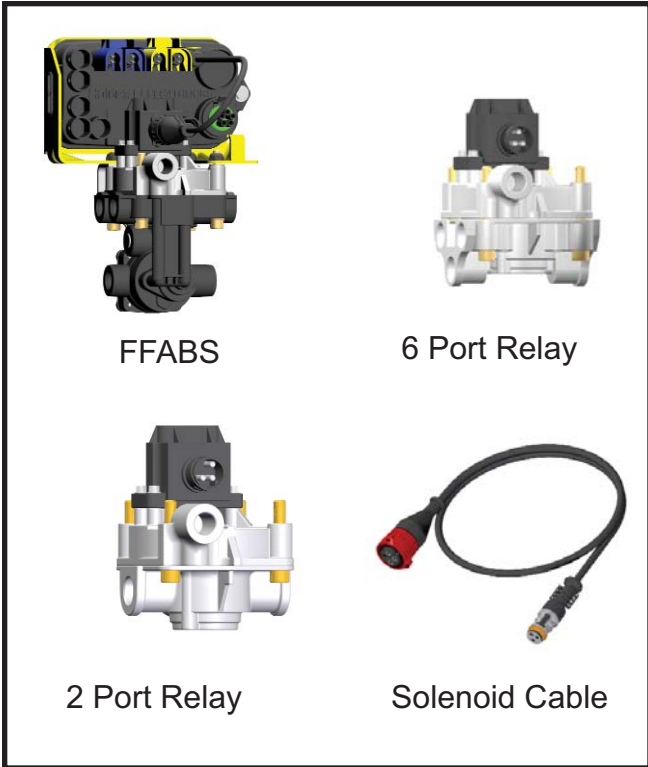

Additional Supplied Items



Haldex Diagnostic Tools

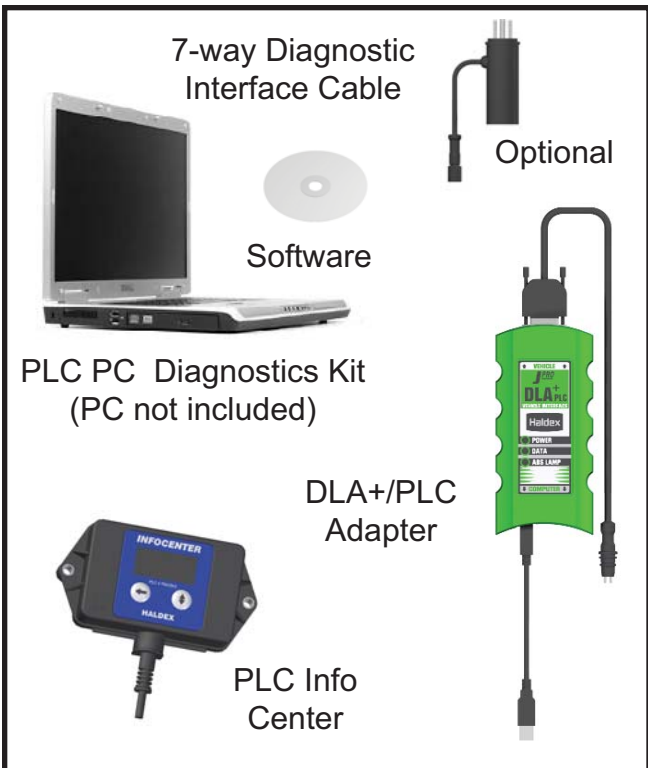

Recommended Installation Aids

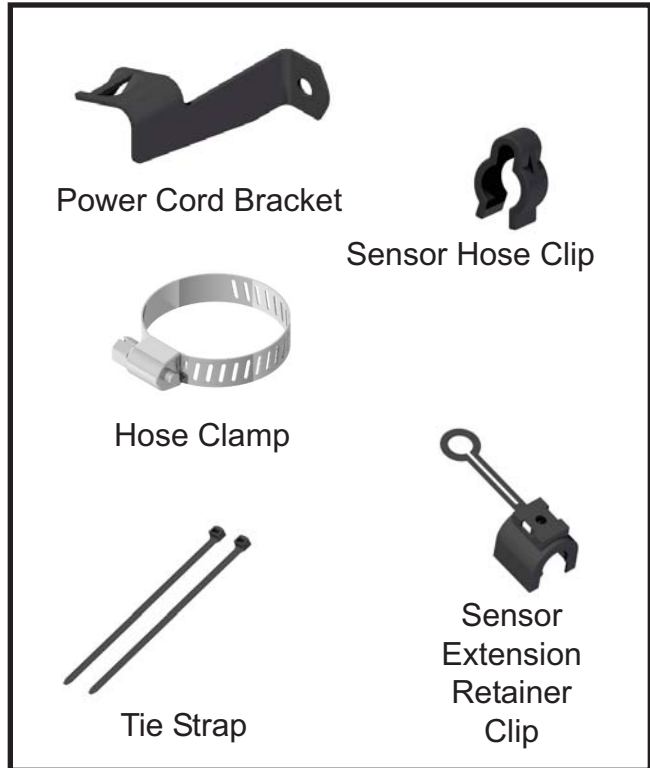

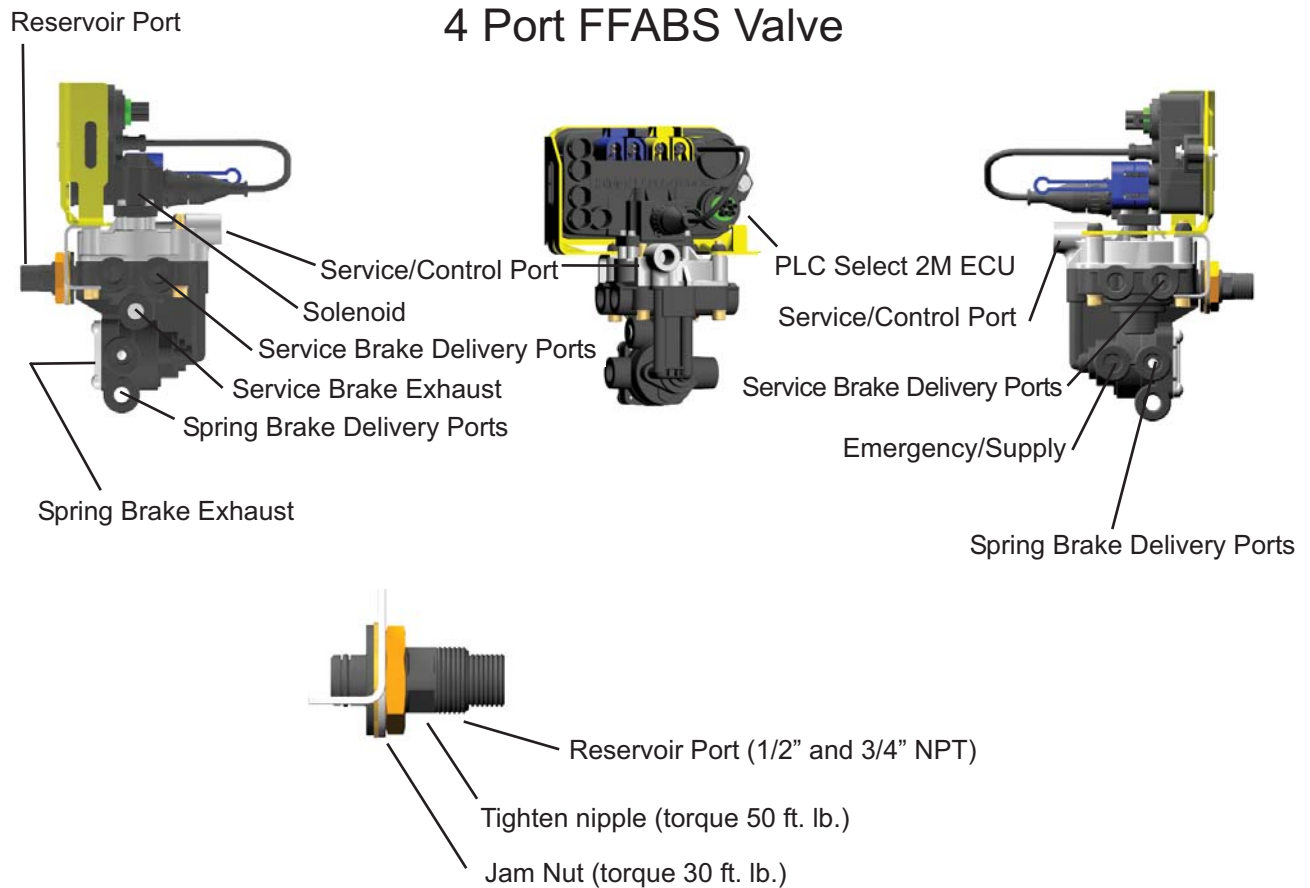

- Notes:**
- (4) Service Brake Port FFABS Valve is the most commonly used for Tandem Axle Trailers.
 - Spring Brake Delivery ports come in two variations (2 or 4 ports)
 - All ports are 3/8" NPT except reservoir nipple (1/2" or 3/4" NPT).
 - Service/Control and Emergency/Supply ports have serviceable Filter/Screen installed.
 - FFABS Valve Spring Brake Exhaust Cover
 - White indicates Spring Brake Priority
 - Black indicates Service Brake Priority



PLC Select 2M ECU/Valve Units Overview

6 Port ABS Relay Valve

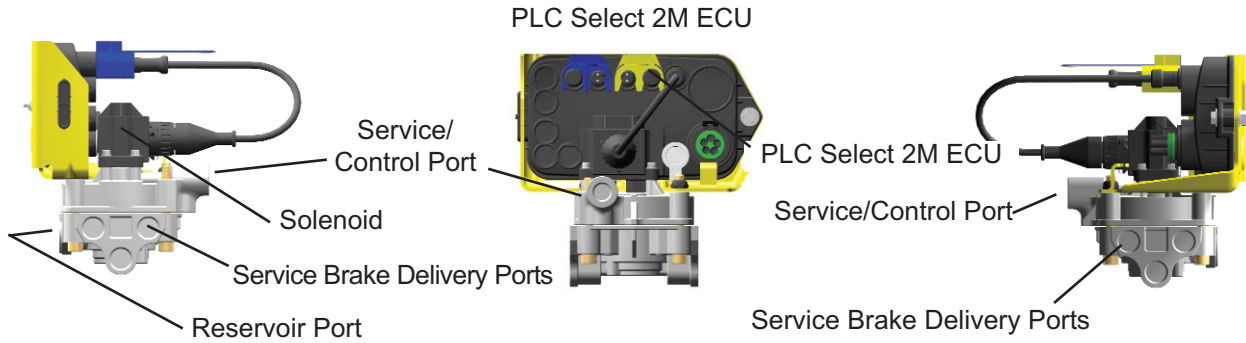

2 Port ABS Relay Valve

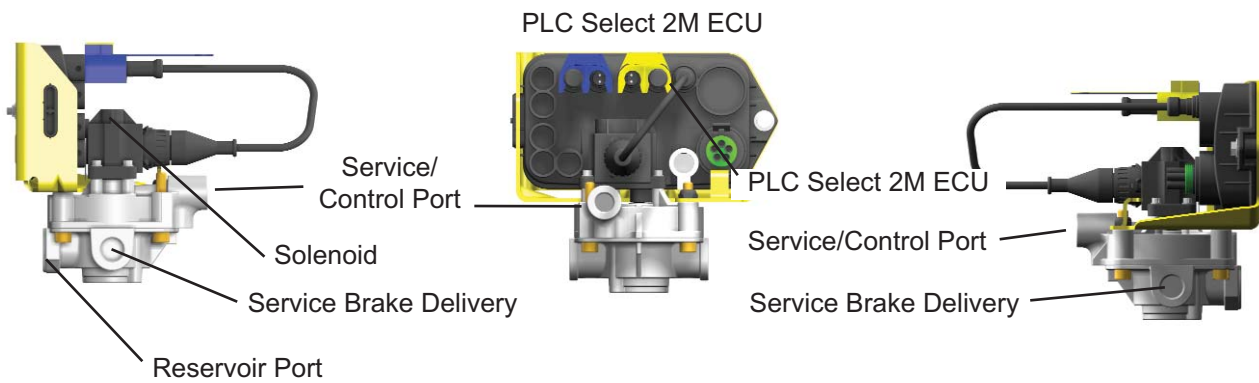

Note: All ports are 3/8" NPT except the reservoir port which is 1/2" NPT.

Trailer Brake Control Valve

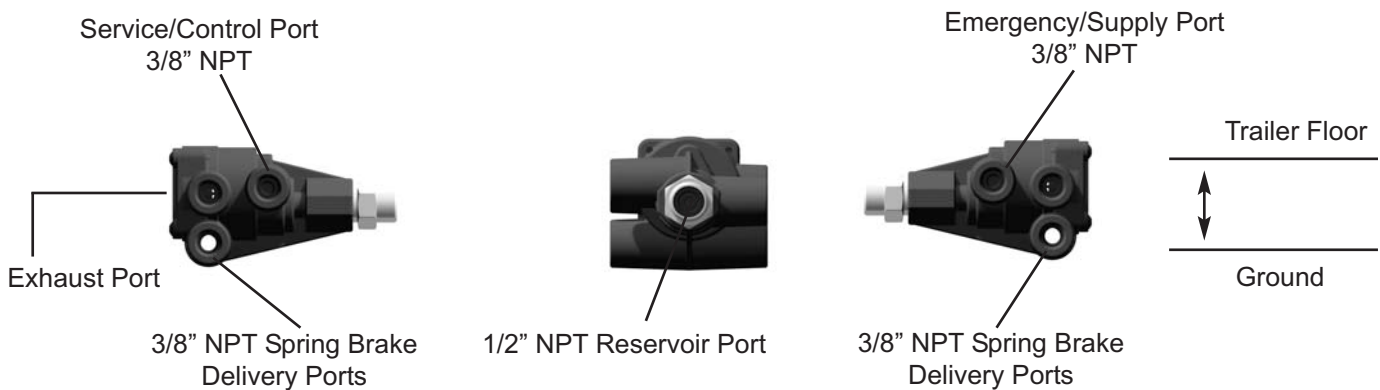

Note:

1. All ports are 3/8" NPT except the reservoir port which is 1/2" NPT.
2. Service/Control and Emergency/Supply ports have serviceable Filter/Screen installed.
3. Install this valve as shown. Exhaust port pointing horizontal.
4. Trailer Brake Control Valve - Exhaust Port - White indicates Spring Brake Priority - Black indicates Service Brake Priority

PLC Select FFABS 4S/2M (2 Service Delivery Ports)



**PLC Select FFABS
(2 Service Delivery Ports)**



**2 Port Relay Valve
(2 Service Delivery Ports)**

Plumbing Schematic (Side-By-Side) Top View

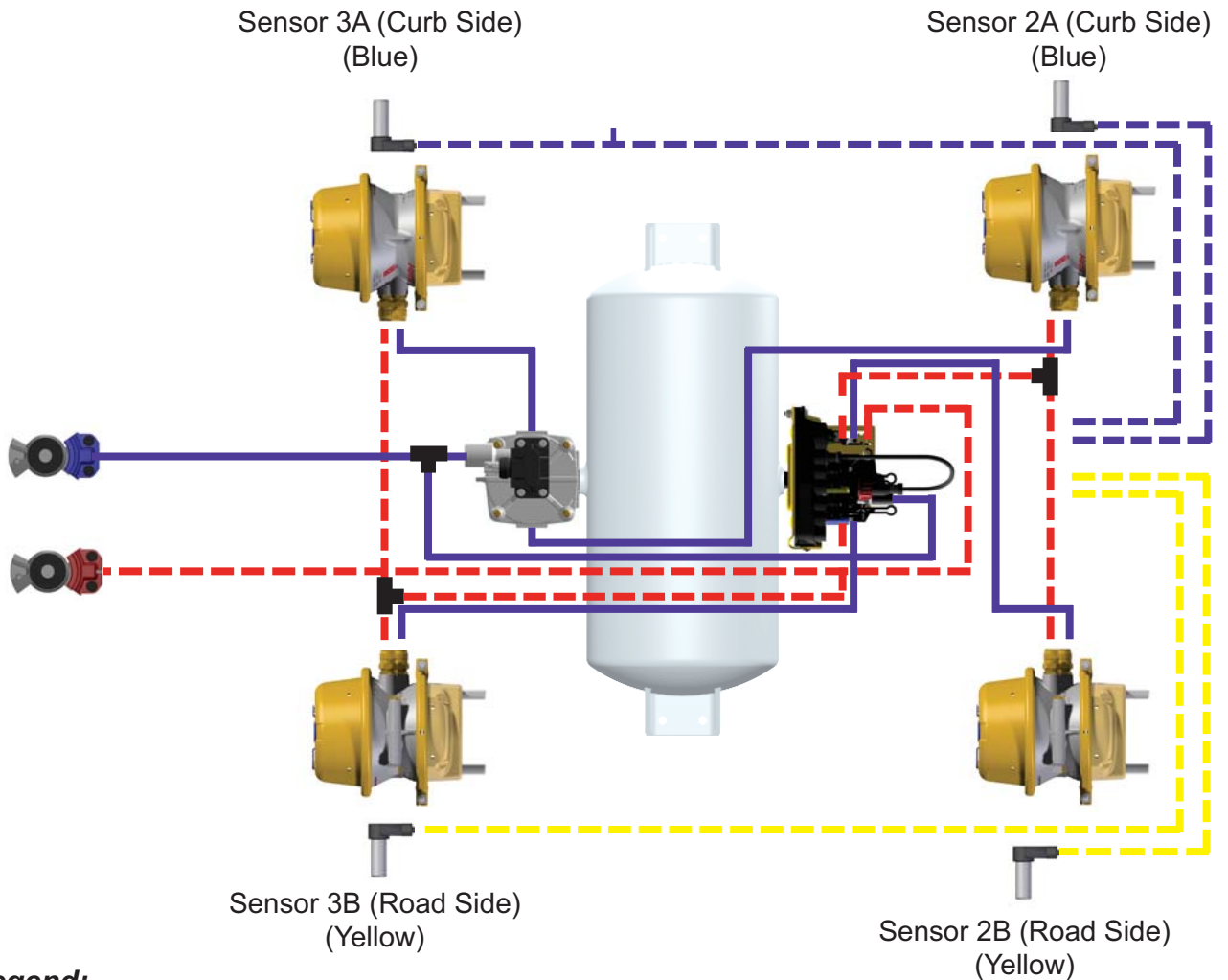

Legend:

Service/Control Line	
Emergency/Supply Line	
Sensor Line	

AIR BRAKE COMPONENTS AND SYSTEM SCHEMATIC ARE DESIGNED TO ALLOW COMPLIANCE WITH FMVSS 121.

THIS SCHEMATIC IS FOR INFORMATION PURPOSE ONLY. IT IS THE VEHICLE MANUFACTURERS ULTIMATE RESPONSIBILITY TO CERTIFY THEIR SYSTEM MEETS ALL APPLICABLE REGULATIONS.

PIPE NIPPLES USED TO MOUNT BRAKE VALVES MUST BE HEAVY WALL TYPE PER SAE J514.



PLC Select 2 Port ABS 4S/2M with Trailer Brake Control Valve

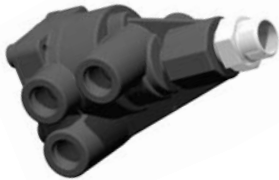

Trailer Brake Control Valve (TBCV)



PLC Select ABS 2M (2 Service Delivery Ports)



2 Port Relay Valve (2 Service Delivery Ports)

Plumbing Schematic (Side-By-Side)

Top View

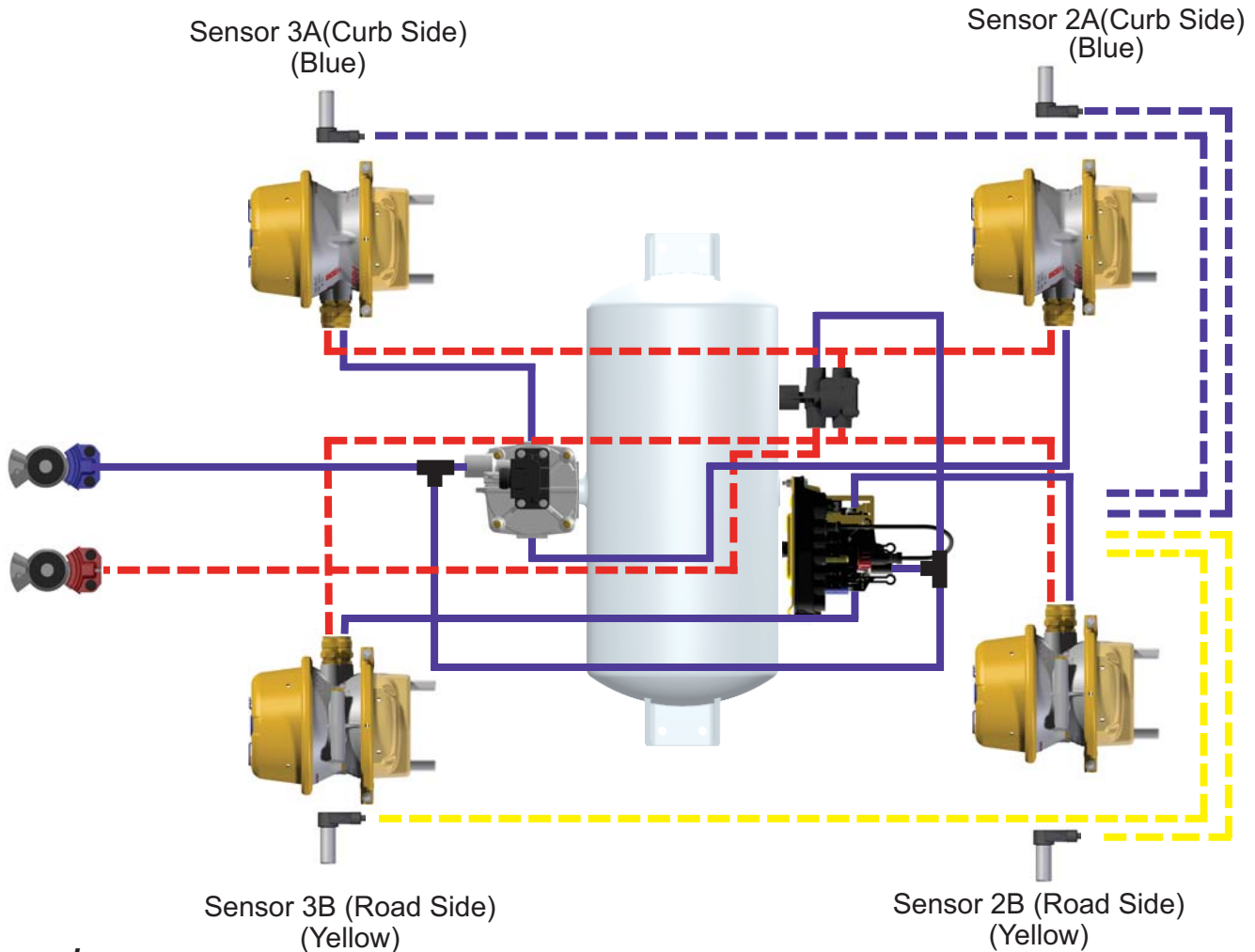

Legend:

Service/Control Line	
Emergency/Supply Line	
Sensor Line	

AIR BRAKE COMPONENTS AND SYSTEM SCHEMATIC ARE DESIGNED TO ALLOW COMPLIANCE WITH FMVSS 121.

THIS SCHEMATIC IS FOR INFORMATION PURPOSE ONLY. IT IS THE VEHICLE MANUFACTURERS ULTIMATE RESPONSIBILITY TO CERTIFY THEIR SYSTEM MEETS ALL APPLICABLE REGULATIONS.

PIPE NIPPLES USED TO MOUNT BRAKE VALVES MUST BE HEAVY WALL TYPE PER SAE J514.

PLC Select FFABS 4S/2M (2 Service Delivery Ports)



**PLC Select FFABS
(2 Service Delivery Ports)**



**2 Port Relay Valve
(2 Service Delivery Ports)**

Plumbing Schematic (Axle-By-Axle)

Top View

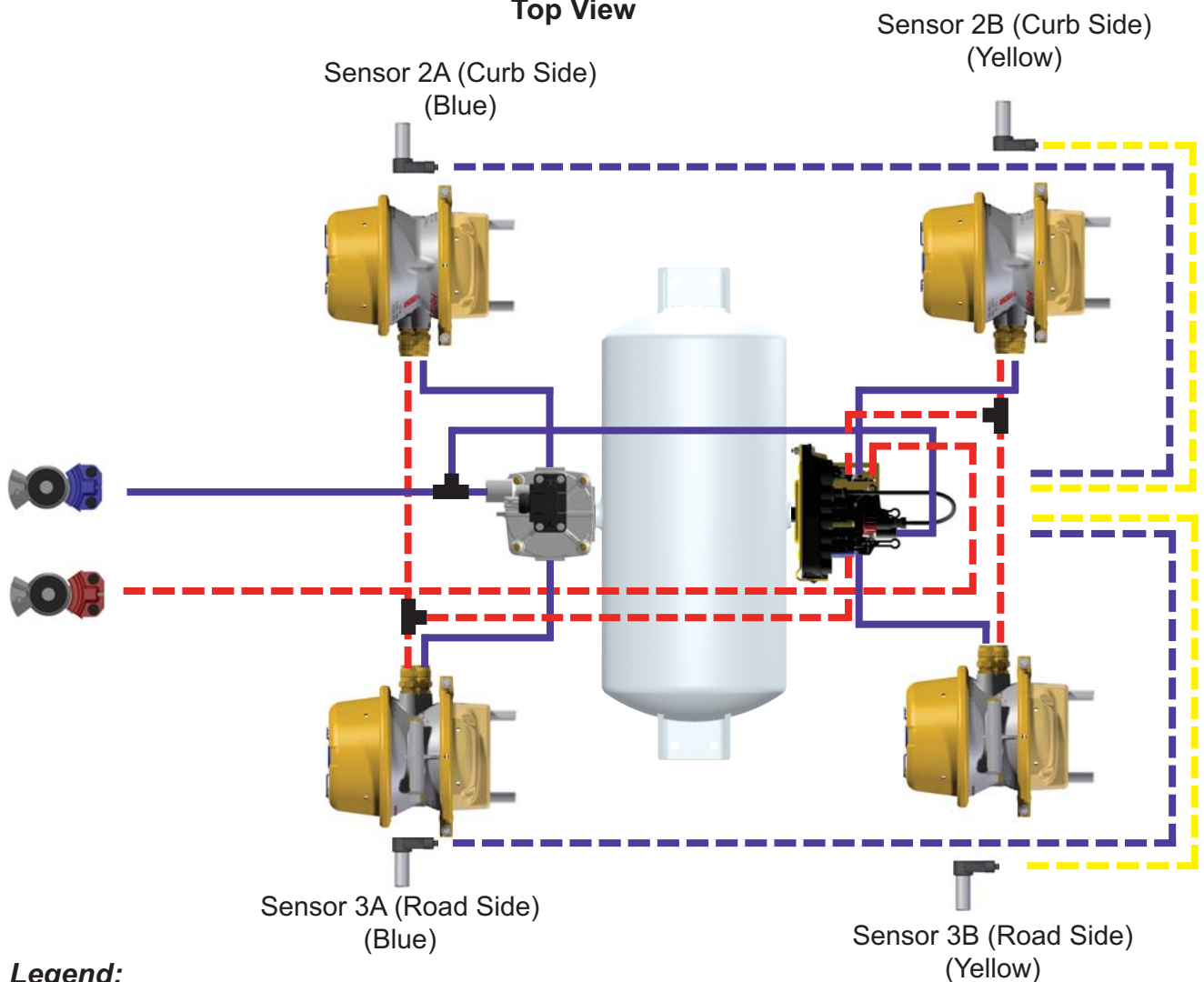

Legend:

Service/Control Line	
Emergency/Supply Line	
Sensor Line	

AIR BRAKE COMPONENTS AND SYSTEM SCHEMATIC ARE DESIGNED TO ALLOW COMPLIANCE WITH FMVSS 121.

THIS SCHEMATIC IS FOR INFORMATION PURPOSE ONLY. IT IS THE VEHICLE MANUFACTURERS ULTIMATE RESPONSIBILITY TO CERTIFY THEIR SYSTEM MEETS ALL APPLICABLE REGULATIONS.

PIPE NIPPLES USED TO MOUNT BRAKE VALVES MUST BE HEAVY WALL TYPE PER SAE J514.



PLC Select 2 Port ABS 4S/2M with Trailer Brake Control Valve

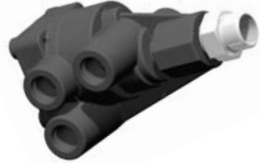

Trailer Brake Control Valve (TBCV)



PLC Select ABS 2M (2 Service Delivery Ports)



2 Port Relay Valve (2 Service Delivery Ports)

Plumbing Schematic (Axle-By-Axle)

Top View

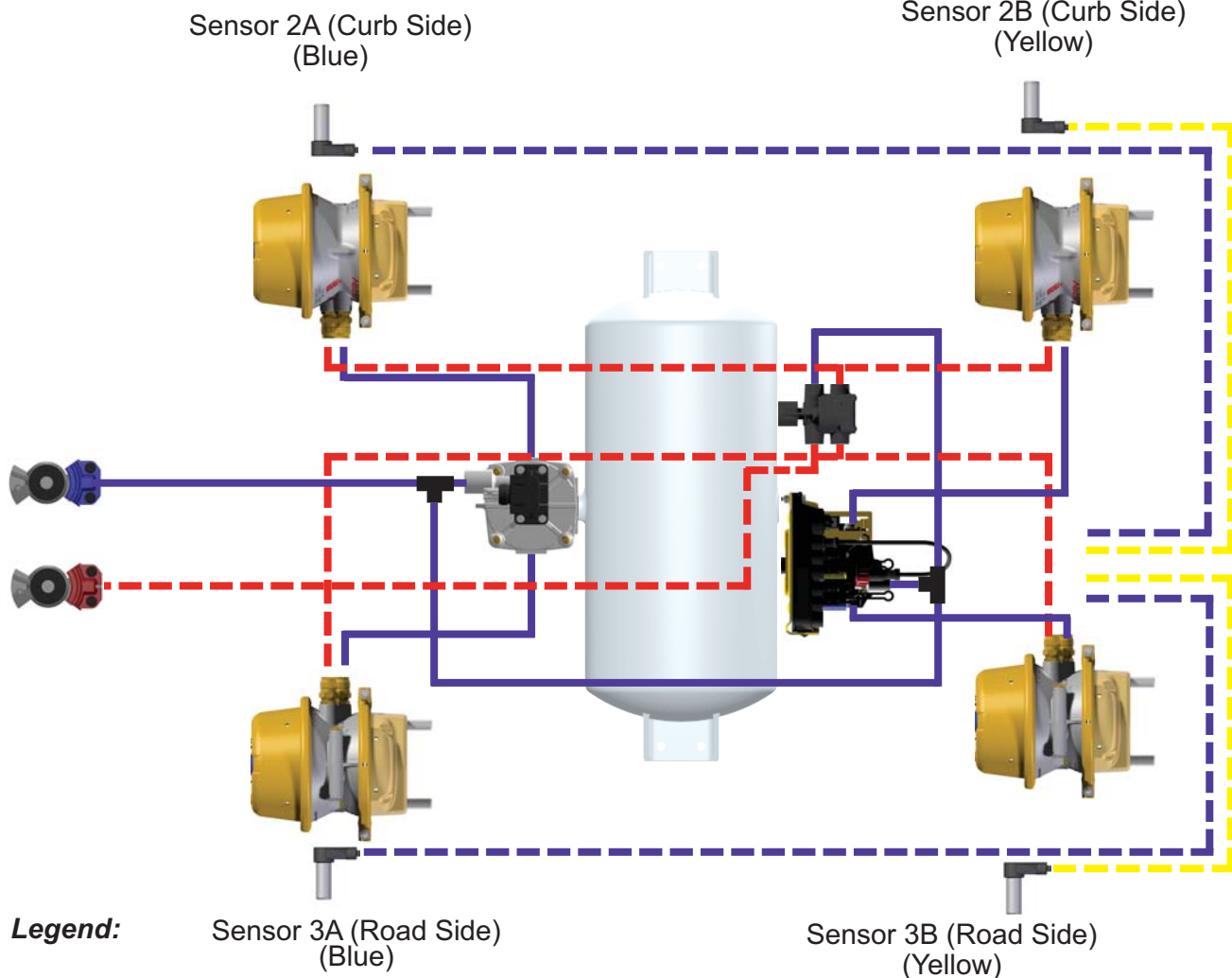

AIR BRAKE COMPONENTS AND SYSTEM SCHEMATIC ARE DESIGNED TO ALLOW COMPLIANCE WITH FMVSS 121.

THIS SCHEMATIC IS FOR INFORMATION PURPOSE ONLY. IT IS THE VEHICLE MANUFACTURERS ULTIMATE RESPONSIBILITY TO CERTIFY THEIR SYSTEM MEETS ALL APPLICABLE REGULATIONS.

PIPE NIPPLES USED TO MOUNT BRAKE VALVES MUST BE HEAVY WALL TYPE PER SAE J514.

PLC Select FFABS 4S/2M Full Trailer Plumbing Schematic (Axle-By-Axle)



**PLC Select FFABS
(2 Service Delivery Ports)**



**2 Port Relay Valve
(2 Service Delivery Ports)**

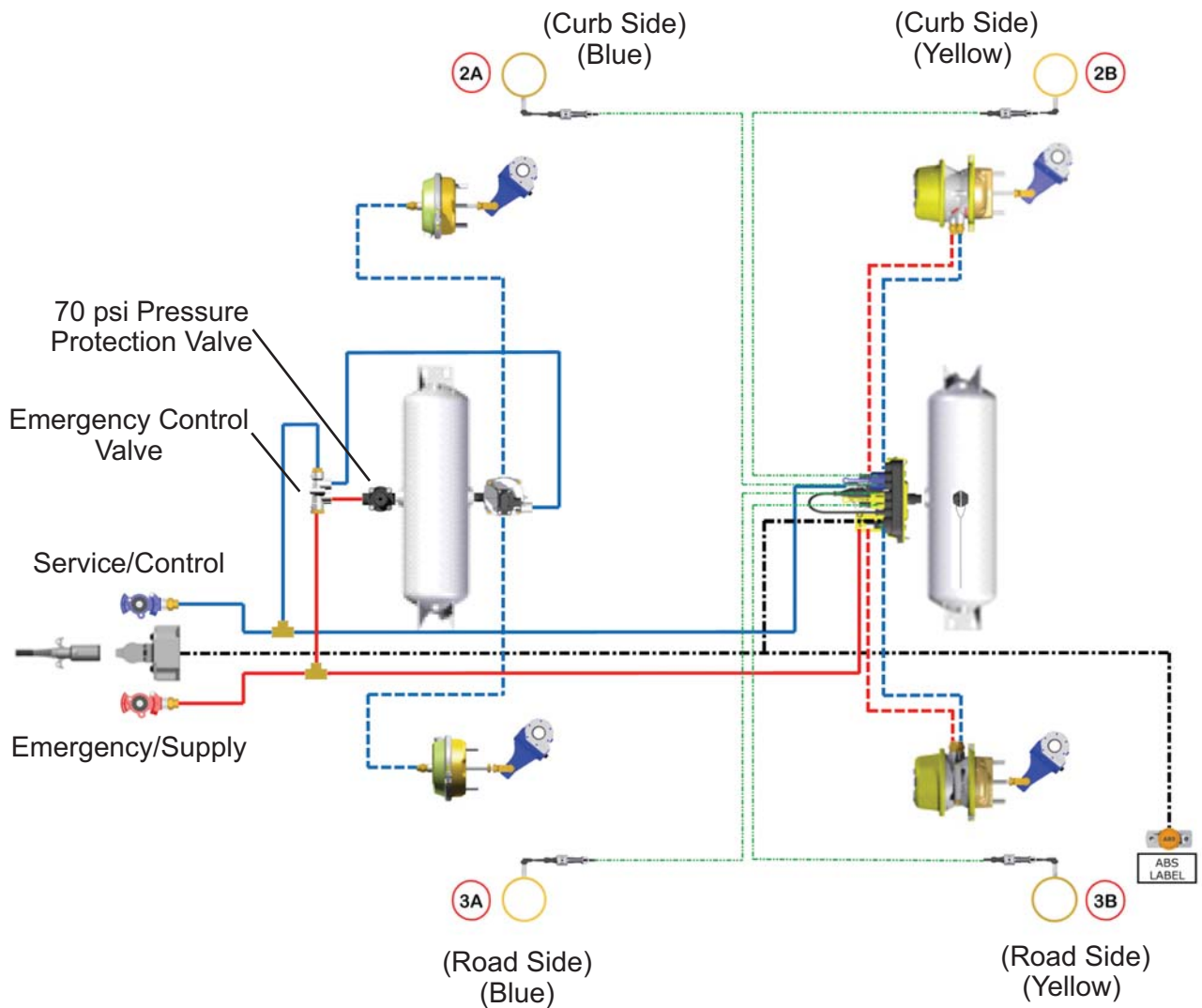



PLC Select 2M ECU Overview

If 2S/1M is desired, use sensors S2B and S3B. Use blanking plugs in unused sensor connections.

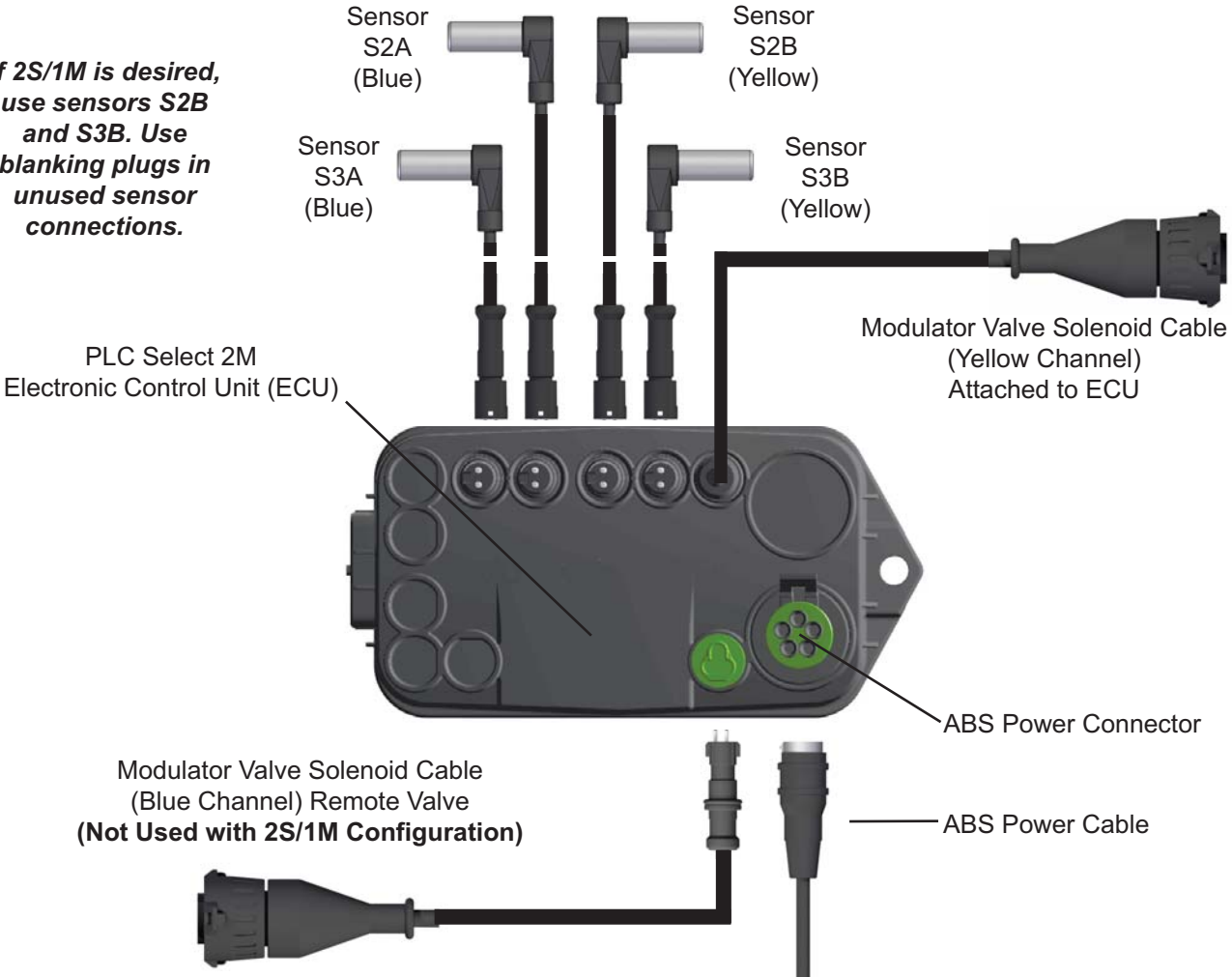

Verify connection locking tab (shown below) is facing downward and secure. If cable can be removed without releasing locking tab, verify connector orientation.

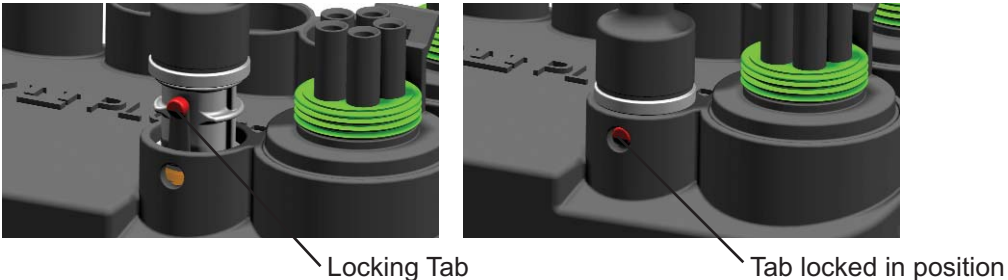

Correct location of the speed sensors at the wheel ends is critical for proper ABS operation. Incorrect installation or location of speed sensors and exciter rings will result in poor ABS performance or sensors crossed leading to incorrect diagnostic troubleshooting. The figure above shows the correct power and speed sensor connections on the PLC Select 4S/2M ECU (Electronic Control Unit) **“See Haldex Trailer ABS Service Components Catalog L20243 for sensor extensions if short sensors are used”**.

4S/2M System Wiring - PLC Select (Side-By-Side)



4S/2M Wiring Overview

For a detailed view of sensor ECU connections see 2M ECU Overview on Page 32)

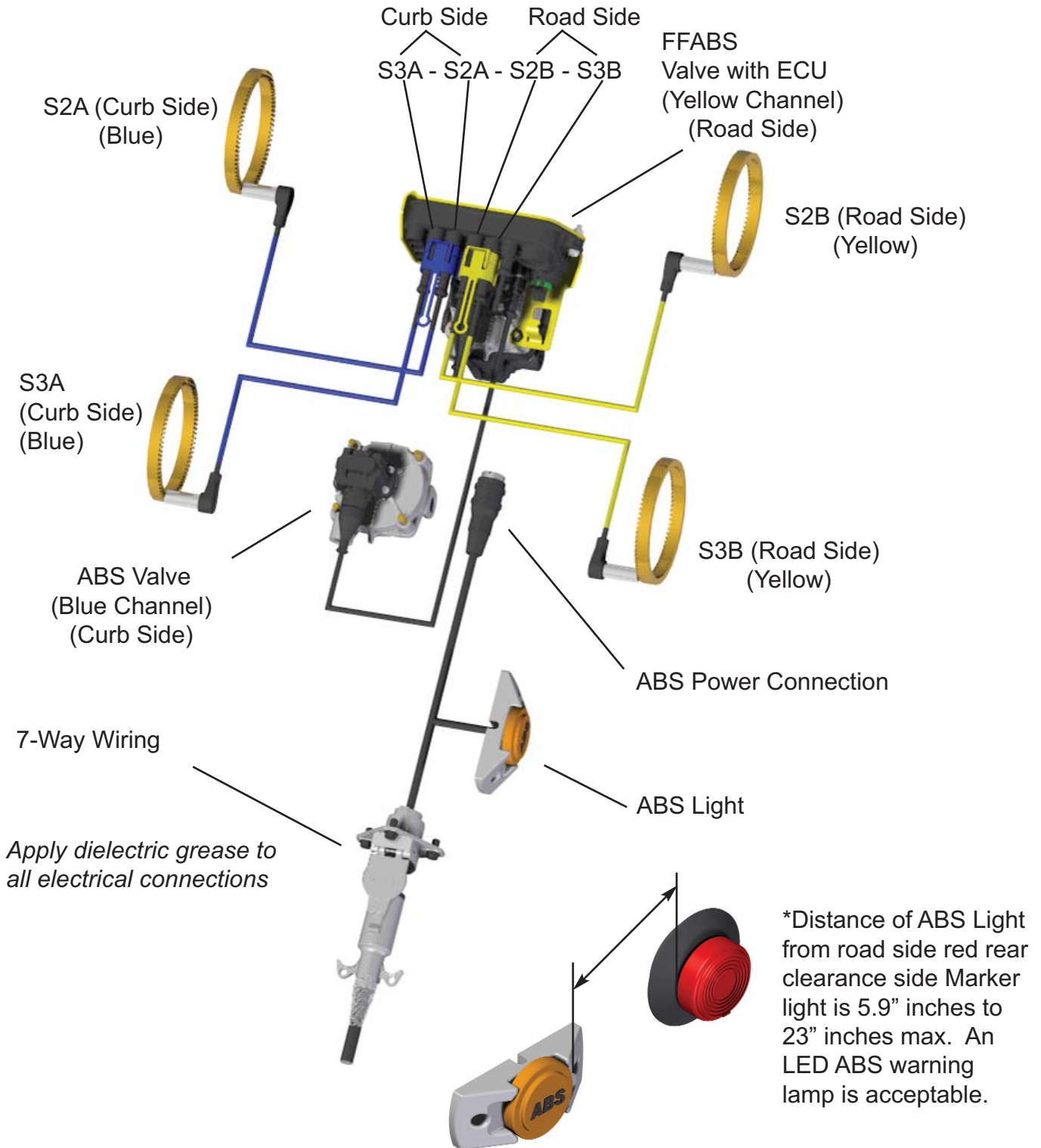



4S/2M System Wiring - PLC Select (Axle-By-Axle)

4S/2M Wiring Overview

For a detailed view of sensor ECU connections
see 2M ECU Overview on Page 32)

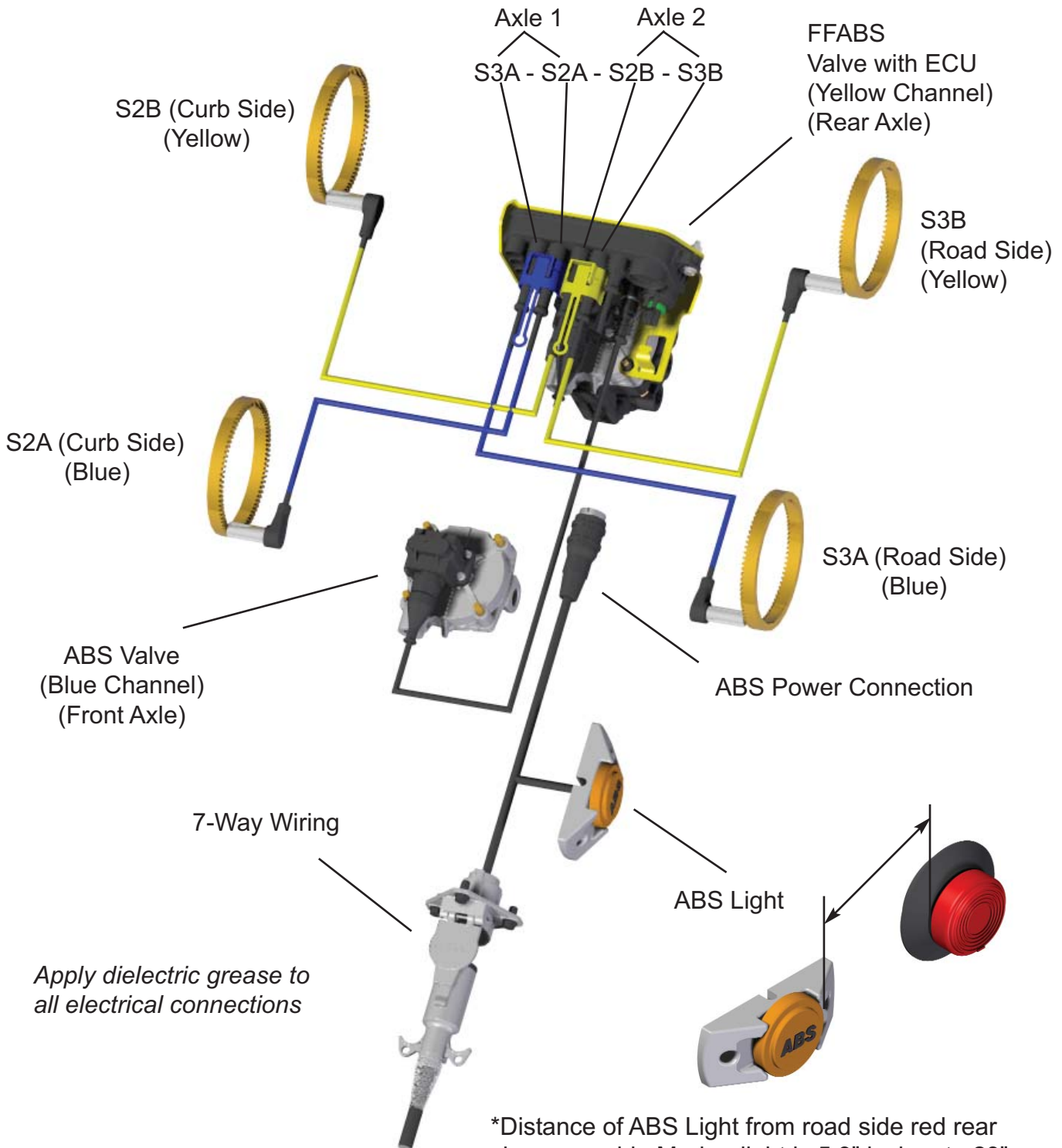

*Distance of ABS Light from road side red rear clearance side Marker light is 5.9" inches to 23" inches max. LED ABS lamps are acceptable.

4S/2M System Wiring - PLC Select

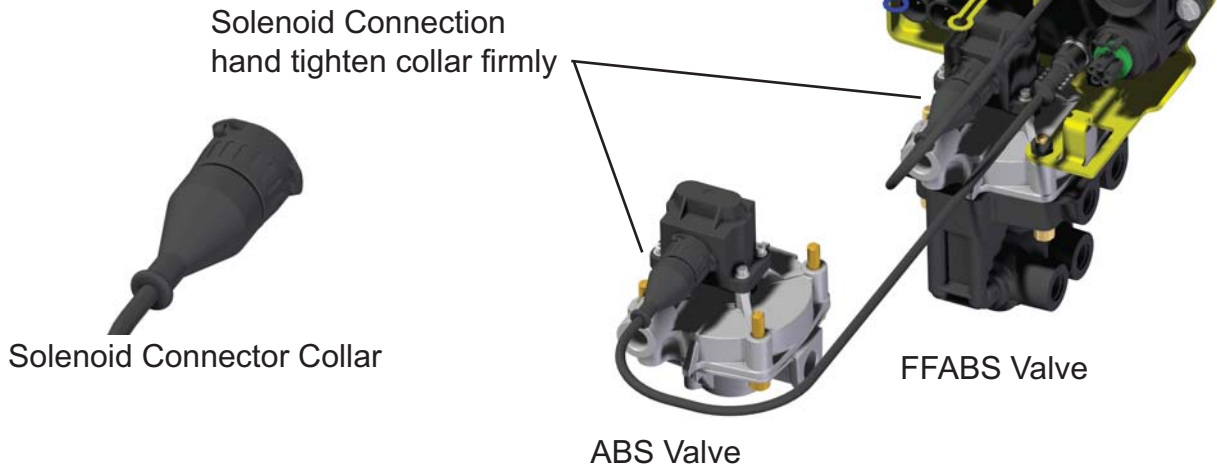

Fully push the ABS Power Cable onto the ABS Power Connector and be sure the tab locks into place.

Insert sensor cable into the correct location on the ECU and push sensor retainer clip over sensor cable to secure them in place.

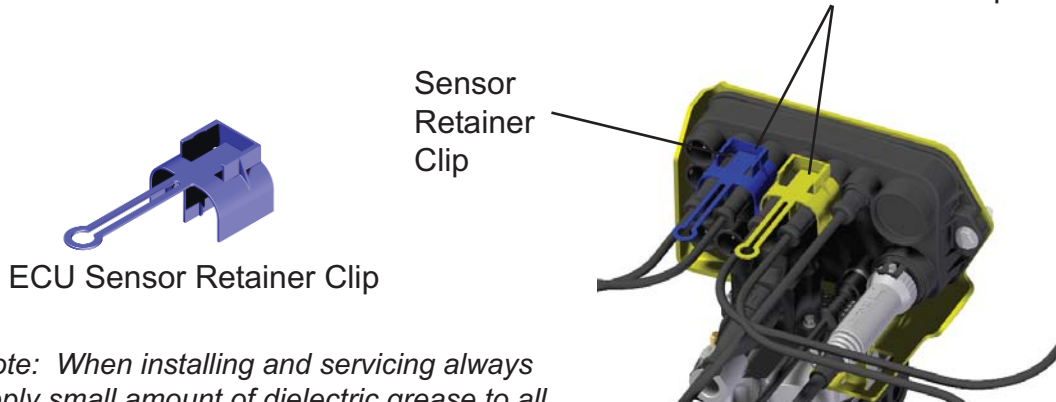

Note: When installing and servicing always apply small amount of dielectric grease to all electrical connections.



Speed Sensor Cable Routing

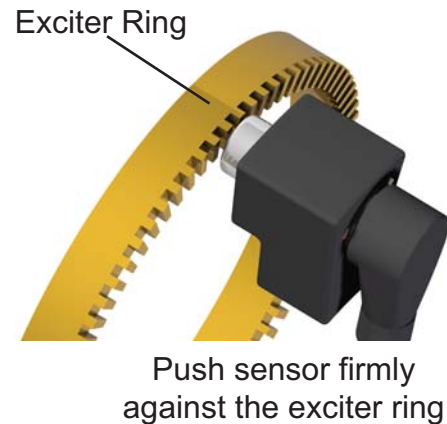
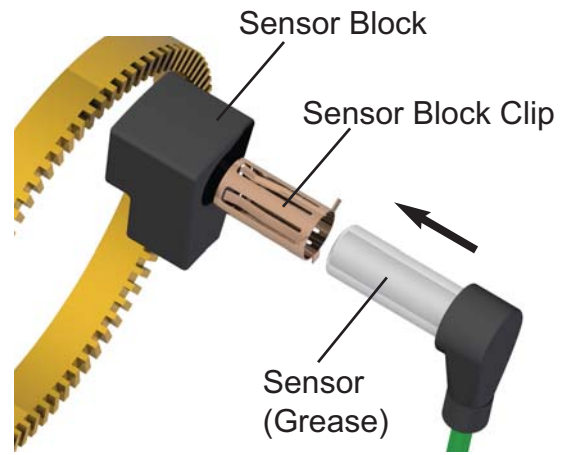
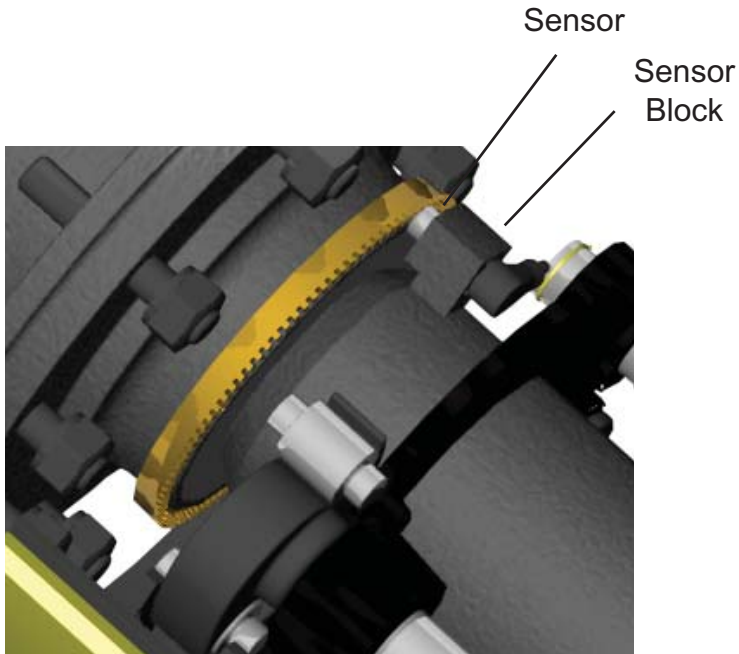

Note: Lightly grease the sensor with a Lithium based grease. Use Dow Corning Molycoat CU7439 or equivalent.

1. Insert the sensor block clip into the sensor block (as shown above).
2. Grease the sensor with a lithium based grease or anti-seize then insert the sensor into the sensor block clip and push until it is firmly against the exciter ring (as shown above).
3. Route all sensor cables through vacant holes, etc. Use a grommet or corrugated tubing if the cables are touching sharp edges.
4. Attach cable ties as needed to ensure the cable is secured to the axle housing.
5. Typical routing of cable is along the brake chamber air hose.
6. Use sensor cable hose clip when attaching the cables to the air hoses.
7. Sensor cable hose clips should be no farther than 8-10" inches apart.

Note: Haldex does not recommend the use of tie straps to secure sensor wires to rubber air hoses. Expansion of rubber air hoses will damage sensor wires causing ABS sensor failure.

Speed Sensor Cable Routing



Although it is possible to route cables along the axle, the preferred approach is to route the speed sensor cables along the air hoses between the ABS valve and the brake actuators.

Tie straps should not be used to secure the speed sensor cable to air hoses. For a more reliable installation use sensor hose clips to secure speed sensor cables to rubber air hoses.

Leave some slack in cables to accommodate movement between chassis components. Excess cable must not be allowed to hang free and must be bundled and attached to the chassis to prevent damage due to vibration and abrasion.

Route sensor wire on backside of axle housing to avoid damage from road debris.

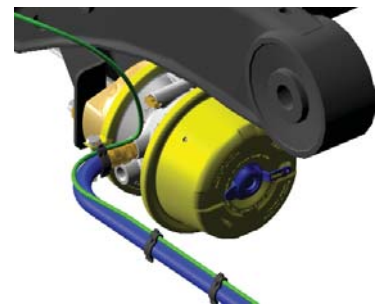
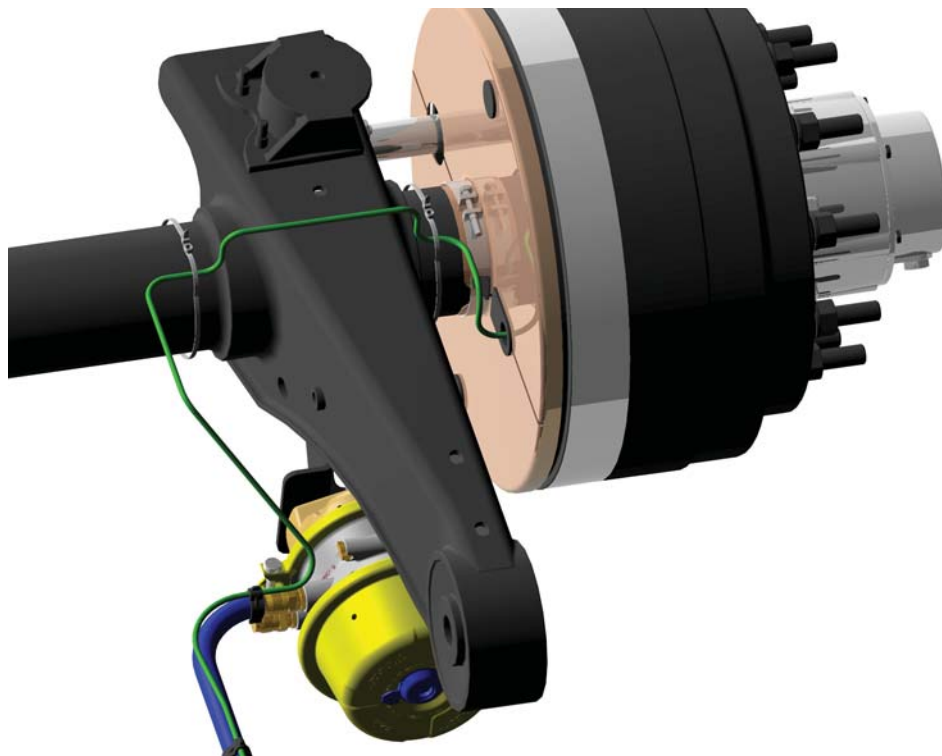

A sensor hose clip is placed on the hose and sensor wire.



Sensor Hose Clip

Excess cable length may be taken up in either a “short bone” or a “long bone” arrangement and secured with tie straps. Do not coil the cable into a loop smaller than 4 inches in diameter. Do not over tighten the tie straps when the cable is coiled, as this could cause a cable failure.



Push up and and attach tie straps.



Long cable (long bone)



Short Cable (short bone)



Chassis/End of Line Testing PLC Select 1M - 2M

Test Equipment:

12 Volt DC power source (**Never use a battery charger or internal ECU damage will occur**), power cable with a Packard 5 pin male power connection, an ABS test light attached, and shop air.

Chassis Test/End Of Line ABS Check:

Procedure:

1. Charge the Emergency/Supply and Service/Control air systems.(100 - 120 psi)
2. Apply power source to 7-Way receptacle (PIN 7 - permanent power).
3. The ABS Valve(s) should "**blow down**" first. You will hear a brief exhaust of air from each valve. The Blue Channel (remote valve) should blow down first followed by the Yellow Channel (ECU valve) (for a 2S/1M system the Red Channel valve only).
4. The ABS light should illuminate for about 3 seconds and then turn off.
5. Using an Info Center or PC verify correct sensor placement by spinning each wheel end one at a time. Refer to pages **6 - 11** for correct placement. Axle-By-Axle, or Side-By-Side. **Refer to L31158 for Info Center instructions.**
6. When using a PC in conjunction with Haldex PC diagnostics, information such as the name of the Inspector, the date inspected, or the trailer VIN can be stored in the ABS ECU.

Note: If the ABS Light never illuminates or stays illuminated during the ABS check, refer to Troubleshooting Section on page **49** of this manual.





Road Test - PLC Select 1M-2M:

Procedure:

1. Connect a tractor to the trailer and charge the trailer's air tanks. (100 - 120 psi)
2. Turn on the start switch and ensure that the ABS Warning Light comes on briefly, then goes out.
3. Pull the trailer at a speed above 6 mph, make a brake application and hold until the tractor-trailer has come to a complete stop.
4. Verify that the ABS Warning Light has remained **OFF**. If the light remained **OFF**, the system is functioning properly.
5. If the ABS system detected an error during the stop, the Warning Light will be **ON**. If the ABS Warning Light never comes **ON** when the start switch is turned **ON**, then refer to the, "No ABS Warning Light Illumination" section on page **49** of this manual. If the ABS Warning Light stays **ON** with the start switch on, refer to the "ABS Warning Light Stays on permanently" section on page **49** of this manual.

Notes:

1. *Disconnect power from the ABS system before making any repairs.*
2. *Most ABS problems are related to:*
 - a. *Cut or damaged wires*
 - b. *Corroded connector, or terminals*
 - c. *Connector terminals not latched or seated correctly to mating assemblies*
 - d. *Excessive sensor air gap, sensor clip retention, or wheel bearing end play*
 - e. *Verify sufficient power at the ABS Power Cable (12 - 15 Volts DC)*
3. *After making any repairs go to the "Diagnostic Tools" section of this manual (see pages **40-42** to confirm that the fault is corrected). If dynamic fault codes 11 - 16 or 21 - 26 has occurred the ABS Warning Light will remain on with a code **07** when repowered until the problem has been corrected. After correcting the stored fault, the vehicle must be driven **above 6 MPH utilizing permanent power** for the ABS to recognize the problem has been corrected. Verify the ABS light turns off before clearing stored dynamic codes.*



Technical Service & Engineering Support
1-800-643-2374 (press 2)

In Canada, please call 1-800-267-9247

Diagnositics Tools



PLC PC Diagnostics Kit
(PC not included)

SAE 560
7-way Diagnostic
Interface Cable



Blink Codes



PLC Info Center

(Data Link
Adapter)
DLA+/PLC





Haldex provides (3) Methods for ABS Diagnostics:

1. Blink Codes
2. PLC Info Center
3. PLC PC Diagnostics



(1) Blink Codes:

ABS fault codes can be accessed using the ABS light without the use of any other tools. The blink code “**Simple Fault Mode**” can be activated by pressing on the brake pedal to activate the trailer brakes and switching ignition power **ON, OFF, ON** in 1 second intervals. See Blink Code information on pages 43-47.

(2) PLC Info Center:

The PLC Info Center has a screen that can display ABS fault codes plus a number of other functions. The PLC Info Center only needs to be connected to vehicle **permanent power** and ground. An optional SAE 560 7-Way Diagnostic Interface Cable is also available.



Available functions include:

1. View active fault code(s) (2 digit code) and fault occurrence count.
2. View stored fault code(s) and fault occurrence count.
3. Clear stored fault code(s).
4. View wheel speed sensor identification corresponding to each individual wheel when rotated.
5. View sensor and valve configuration code.
6. View ABS ECU type and serial number.
7. Energize valve solenoid(s).
8. Odometer
 - a) View Odometer, Tire Scale Factor, (Miles or Kilometer), Service Interval, and Trip Distance.
 - b) Program Tire Scale Factor (miles or kilometers), and Service Interval.

Reference PLC Info Center Instruction Manual L31158.



(3) PLC PC Diagnostic:

ABS
PC Diagnostic Software.
Also available at
www.haldex.com



PC Diagnostics Kit
(PC not included)

Optional SAE 560 7-Way
Diagnostic Interface Cable



DLA+/PLC
Adapter

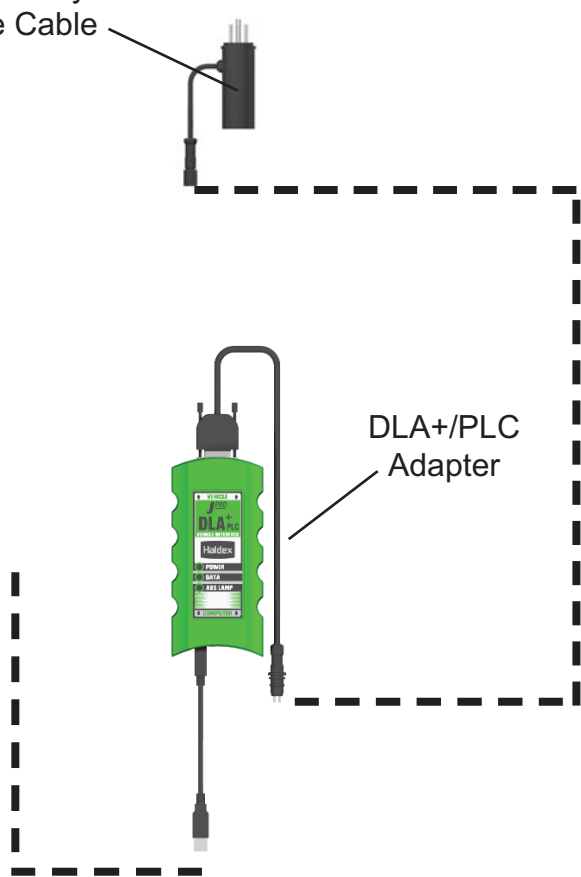

PLC PC Diagnostics displays the most information. Available functions include all the functions of the PLC Info Center as well as:

1. View ABS ECU Part Number.
2. Save ABS diagnostic results for a print out of test verification.
3. Read/Write Trailer and or Service data internally to ABS ECU

Minimum requirements: MS Windows 2000, 32 MB RAM

Note: *PLC Info Center and PLC PC Diagnostics are not compatible with older generations of ABS manufactured prior to March 2001.*

“Reference PC Diagnostic Instruction Manual L31154”.

Blink Code Diagnostics



There are 5 Blink Code Modes:
Apply service brakes and then cycle permanent power (1 second on/ 1 second off)

Mode	Description	Permanent Power Cycles <i>(1 second ON / 1 second OFF)</i> with stoplight power applied.
1	Simple/Wheel Speed Mode	ON, off, ON
2	Active Faults Mode	ON, off, ON, off, ON
3	Stored Faults / Clear Mode	ON, off, ON, off, ON, off, ON
4	Configuration Mode	ON, off, ON, off, ON, off, ON, off, ON
5	Odometer Mode	ON, off, ON, off, ON, off, ON, off, ON, off, ON

Procedure for Blink Code Diagnostics:

1. The trailer must be stationary.
2. The trailer must be connected to a DC-power supply (10-15 volts). Never use a battery charger.
3. Constant **DC** power (10-15 volts) must be provided to the stoplight circuit (apply trailer service brakes).
4. Permanent power must be cycled ON and OFF (trailer auxiliary circuit) at 1 second intervals to reach the desired mode (shown above). *It is recommended that an auxiliary switched power source be used (i.e. light cart).*

Note: *Stoplight and Permanent power must be independent for blink code troubleshooting. If Permanent power is required for your brake lights to operate, then the blink code diagnostics will not function.*

Procedure Notes:

1. Once a blink mode is entered that mode can only be terminated by completely disconnecting all trailer power sources.
2. All modes repeat endlessly. Each repeat is separated by 10 seconds of continuous light energization.
3. All codes are separated by 2 seconds of light **OFF**.
4. Stored fault codes (mode 3) are followed by an occurrence count which display a blink rate twice as fast as the fault code blink rate.

Mode 1 - Simple Mode Diagnostics:

This mode has an abbreviated list of fault codes that will display. Fault codes are grouped to simplify the diagnostics. Up to 3 active codes will be displayed at one time. These faults need to be repaired before other active faults can be displayed. See Simple Mode Faults Code Table on next page.



Blink Code Diagnostics

Mode 1 - Simple Mode Diagnostics Faults Table (ON, OFF, ON):

See the diagnostic codes (pages 50-54) for possible causes

Item	Flash Count	Actual Fault
System OK	Light Stays On	07 (See note below)
Sensor 1A	1 Flash	01
Sensor 1B	2 Flashes	02
Sensor 2A	3 Flashes	03
Sensor 2B	4 Flashes	04
Sensor 3A	5 Flashes	05
Sensor 3B	6 Flashes	06
Red Valve	7 Flashes	61, 67, 71, 77, 81, & 87
Blue Valve	8 Flashes	62, 68, 72, 78, 82, & 88
Yellow Valve	9 Flashes	63, 69, 73, 79, 83, & 89
Low Voltage	10 Flashes	90
ECU Failure	11 Flashes	93, 99, & E-Codes

Note: If the simple mode does not show a fault code, but the ABS light remains “ON” after powering the ABS, there are no active faults present. Verify in mode 3 (stored codes). If any faults 11-16 or 21-26 are present the problem needs to be resolved before the lamp will turnoff when permanent powered vehicle travels > 6 MPH.

Wheel Speed Mode:

Wheel Speed Mode is accessible only when in Simple Mode. This Mode is not activated until the ECU has received a signal from the wheel speed sensor of a spinning wheel. The hold solenoid of the modulator valve associated with the particular sensed spinning wheel will be cycled the same number of times as the lamp flashes. The blink codes for the sensed wheels are as follows:

S1A: 1 Flash S1B: 2 Flashes S2A: 3 Flashes
S2B: 4 Flashes S3A: 5 Flashes S3B: 6 Flashes

Note 1: Spin only one wheel at a time.

Note 2: Once a wheel is rotated, the ABS light will remain on after the wheel is stopped until the next wheel is rotated.

Mode 2 - Active Faults Mode (ON, OFF, ON, OFF, ON):

In this mode the ABS light displays a numerical fault code sequence for each existing fault, up to nine fault codes at a time. The nine faults must be repaired before additional active faults can be displayed. **The blink codes used in the Active Fault Mode are related to the Haldex standard fault codes and are shown on pages 44-48.**

Example: Fault code "23" is indicated by the light flashing ON twice for 1/2 second each time - then off for 2 seconds followed by three 1/2 second flashes.

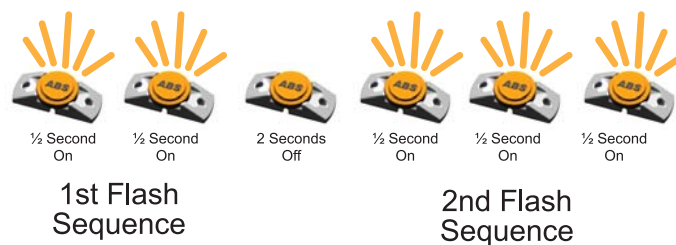

Mode 3 - Stored (Passive) Faults/Clear Mode (ON, OFF, ON, OFF, ON, OFF, ON):

In this mode the ABS light displays a numerical fault code sequence for each stored fault. All stored faults (not currently active) are displayed in this mode. The light will display up to nine passive stored faults at a time. The most recent stored fault is displayed last. The blink codes used in the Passive Stored Fault Mode are related to the Haldex standard fault codes and are shown on page 50-54.

Stored Mode Fault Occurrences (Mode 3):

The fault code blink sequence is followed by the occurrence count for that fault in Passive Mode. The occurrence count is displayed after each pair of fault code flashes in order to differentiate between the code and its occurrence count. Blink code rate twice as fast as the fault code blink rate.

Verify if stored codes 11-16 or 21-26 are present, the problem needs to be resolved before the ABS lamp will shut off when permanent powered vehicle travels > 6 MPH.

Clearing Stored Codes (Mode 3):

The passive stored fault codes may be cleared by switching ignition power OFF, ON OFF, ON while the brakes are applied during the 10 seconds of light energization that occurs prior to each repeat of the fault code blink sequence. The light will flash rapidly for 10 seconds to show that the fault(s) are being erased.

Stored Fault Mode Notes (Mode 3):

1. A “zero” for codes such as “01” is indicated by a two second light “**ON**” condition. All other digits are indicated by a half second light “**ON**” condition.

Example: Fault code “23” is indicated by the light flashing **ON** twice for 1/2 second each time -then off for 2 seconds followed by three 1/2 second flashes. The third flash is the occurrence count and as 1/4 second flashes.

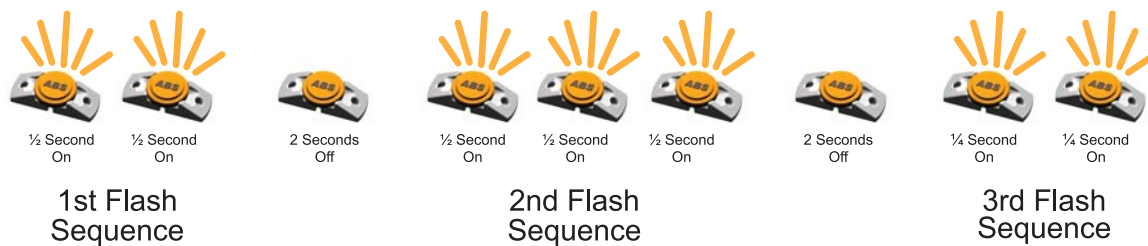

2. There is a two second light “**OFF**” delay between the digits in each code.
3. Code 07 (system **OK**, vehicle at rest) is displayed as a continuous light “**ON**” condition.

Blink Code Diagnostics



Mode 4 - Configuration Mode (ON, OFF, ON, OFF, ON, OFF, ON, OFF, ON):

This Mode displays Configuration and Auxiliary Codes. The Configuration Code is displayed prior to Auxiliary Codes. The tables on page 54 show a list of Configuration Codes and a list of Auxiliary Codes which supported by Blink Codes. Auxiliary Codes are displayed low to high. Each blink code digit will refer to a digit in the Haldex configuration codes.

Config Code	Blinks	Function	Lift Axle	Sensor Used (indicates lift axle)	Modulators Used
CO	1	2S/1M		S1A S1B	Red
C1	2	2S/2M		S2A S2B	Blue, Yellow
C2	3	4S/2M		S3A S2A S2B S3B	Blue, Yellow
C3	4	4S/2M	2 or 3 only	(S3A) S2A S2B (S3B)	Blue, Yellow

Item	Blinks	Description
A0	1	Not Applicable
A1	2	Not Applicable
A2	3	Not Applicable
A3	4	Not Applicable
A4	5	No load sense valve - momentarily displayed when power is applied
A5	6	Not Applicable
A6	7	Not Applicable
A7	8	SLH programming for yellow valve channel (red valve is 2S/1M)
A8	9	MSLH programming for yellow valve channel (red valve is 2S/1M)

Clear Configuration Mode:

The configuration codes may be cleared by switching Permanent power OFF, ON, OFF, ON while the brakes are applied during the 10 seconds of light energization that occurs prior to each repeat of the fault code blink sequence. The light will flash rapidly for 10 seconds to indicate that the configuration has been erased from the ECU's memory. The ECU will then store its full configuration on the next power up.

Mode 5 - Odometer Mode (ON, off, ON, off, ON, off, ON, off, ON, off, ON)

This mode displays the odometer value.

Example: 4364.7 miles (4 on/off 1/2 sec flashes, 3 on/off 1/2 sec flashes, 6 on/off 1/2 sec flashes, 4 on/off 1/2 sec flashes, then 2 on/off 1/4 sec flashes) if set for miles, 1 on/off 1/4 sec flash if set for kms



PLC Select 1M / 2M Tire Scale Factor Chart

Trailer Tire	Scaling Factor 100T (miles)	Scaling Factor 100T (km)	Scaling Factor 80T (miles)	Scaling Factor 80T (km)
80T Smallest Tire			579	360
215/75R17.5			543	338
8R17.5			538	334
275/65R17.5HC			527	328
8.5R17.5			524	326
245/70R17.5			523	325
235/75R17.5			523	325
225/70R19.5			521	324
8.25R15			495	308
9R17.5HC			495	308
10R17.5			490	304
265/70R19.5			483	300
285/70R19.5			470	293
100T Smallest Tire	580	360		
305/70R19.5	574	357	459	286
11R17.5HC	568	353	454	283
10.00R15TR	566	352	453	282
255/70R22.5	566	352	453	282
275/70R22.5	545	339	436	271
10R22.5	520	323	416	259
9.00R20	519	323	415	258
295/75R22.5	518	322	414	258
285/75R24.5	504	313	403	251
295/80R22.5	503	313	402	250
11R22.5	502*	313	402	250
10.00R20	501	312	401	249
315/80R22.5	491	305	383	244
80T Largest Tire			391	243
11.00R20	488	303		
305/75R24.5	488	303		
11R24.5	478	297		
10.00R22	478	297		
12.00R20	472	294		
425/65R22.5	471	293		
11.00R22	466	290		
100T Largest Tire	391	243		

*Haldex Factory Tire Scale Set At Default 502 Rev/Mile.

USEFUL NUMBERS: 1 mile = 1.6093 km

1km = 0.6214 miles

SCALE FACTOR (SF) FOR OTHER TIRE SIZE:

Option 1 SF = (1000/Rc) x (T/100)
 Rc = Rolling Circumference in meters
 T = Exciter actual teeth count

Option 2: SF = N x (T/1000)
 N = Revolutions per mile
 T = Exciter actual teeth count

Note: Scale factor does not affect ABS performance but does affect odometer accuracy.

Troubleshooting ABS Warning Light PLC Select 1M / 2M



ABS Warning Light Stays On Permanently:

Upon power up of the ABS system (Permanent or Stoplight Power), the ABS Warning Light should come **ON** for 3 seconds and then go **OFF**. If the Light stays **ON**, it may be caused by improper light wiring, or by a fault in the ABS system..

1. Check for diagnostic fault codes. If anything other than a “07” is displayed, review the “Troubleshooting” section of this manual (page 50 - 54) for possible solutions. After the problem is repaired, clear all stored faults.
2. **If a “07” is displayed but there was a 11 -16 or 21 - 26 stored in memory, then correct the problem and drive the trailer using permanent power above 6 mph to get the ABS Light to turn OFF.**
3. If there are no stored faults and a “07” is displayed, and the ABS Light is still **ON**, then the ABS Light is mis-wired. Remove the main wire harness 5 pin connector at the ECU and verify continuity between pin “D” (Refer to ABS Power Cord - Pin Out page 19) and trailer ABS Light. The remaining light wire must be grounded to the trailer chassis or connected to the SAE J560 7-Way connector ground wire. Check for continuity between the ABS Light wire and ground. Repair as necessary and retest.
4. If the solenoid does not energize (click, click) when power is applied or the diagnostic tool has nothing on the display, check power on the blue or red wire of the 7-Way connector as well as the ABS Power Cord. (Refer to ABS Power Cord - pin out - page 19).

No ABS Warning Light Illumination:

1. Check the bulb to verify that it is functional. If not functional, replace it.
2. Verify that there is power to the ECU and the solenoid energizes (click, click). If not, disconnect the main wire harness 5 pin connector and check for positive power between either stop light power with brakes applied or permanent power and ground (Refer to ABS Power Cord - Pin Out page 19). The voltage drop between the SAE J560 7-Way and the ECU should not exceed 2 volts. If no power exists at either stoplight or permanent power in reference to ground then check continuity from these pins to the SAE J560 7-Way connector red and blue circuits. Make necessary repairs and retest.
3. If the problem is still present, remove the main wire harness 5 pin connector at the ECU and verify continuity between pin “D” (Refer to ABS Power Cord - Pin Out page 19) and the light. The remaining light wire must be grounded to the trailer chassis or connected to the SAE J560 7-Way connector ground wire. Check for continuity between the ABS light wire and ground. Repair as necessary and retest.



Troubleshooting PLC Select 1M / 2M Diagnostics Codes

Fault Code	Explanation:	Possible Causes:	PLC Select 1M	PLC Select 2M
Occurs only when vehicle is stationary				
00	System OK (with vehicle traveling > 6 mph)	ABS is operational Displays "00" when traveling > 6 MPH	X	X
01	Red channel wheel speed sensor wiring S1A has an Open or Short circuit.	<p>Indicates a wheel speed sensor or its wiring has short or open circuit.</p> <p>Disconnect the relevant sensor and measure the resistance between the two pins in the sensor connector housing.</p> <p>If sensor extensions are used verify extension continuity and connections. Replace sensor and/or extension cable.</p> <p>The Ohm meter reading for the sensor or sensor and extension cable should be between 980 and 2350 Ohm (.98K and 2.35 K Ohm) If not, replace sensor and/or extension cable.</p>	X	
02	Red channel wheel speed sensor wiring S1B has an Open or Short circuit.		X	
03	Blue channel wheel speed sensor wiring S2A has an Open or Short circuit.			X
04	Yellow channel wheel speed sensor wiring S2B has an Open or Short circuit.			X
05	Blue channel wheel speed sensor wiring S3A has an Open or Short circuit.			X
06	Yellow channel wheel speed sensor wiring S3B has an Open or Short circuit.			X
07	System OK (No Active Fault)	ABS ECU is fully operational. Displays "07" vehicle is stationary.	X	X
Occurs only when vehicle is moving				
11	Red channel speed sensor S1A, has low sensor output.	<p>Sensor or spring clip is worn or not properly adjusted, wiring open or short circuit, wheel bearing not properly adjusted (these faults will only occur at speeds greater than 6 mph). Measure the AC voltage at the sensor in question while rotating the wheel at a rate of about one revolution every two seconds. The output should be at least 200 millivolts (0.2 VAC). If this is not the case, push in the sensor until it touches the exciter and rotate the wheel again. If this doesn't correct the problem, then the sensor and sensor block clip should be replaced.</p> <p>If sensor extensions are used verify extension continuity and connections. Replace sensor and/or extension cable.</p> <p>Inspect exciter teeth for minor damage or teeth filled with debris.</p> <p>Verify all exciters have the same number of teeth.</p> <p>Verify sensor and valve wiring/plumbing is correct.</p> <p>See side by side axle by axle configurations</p>	X	
12	Red channel speed sensor S1B, has low sensor output.		X	
13	Blue channel speed sensor S2A, has low sensor output.			X
14	Yellow channel speed sensor S2B, has low sensor output.			X
15	Blue channel speed sensor S3A, has low sensor output.			X
16	Yellow channel speed sensor S3B gap too large. Gap should be kept to a minimum.			X

Troubleshooting PLC Select 1M / 2M Diagnostics Codes



Fault Code	Explanation:	Possible Causes:	PLC Select 1M	PLC Select 2M
------------	--------------	------------------	---------------	---------------

Occurs only when vehicle is moving

21	Red channel wheel speed sensor S1A has an erratic output voltage.	<p>Loose sensor, connection, bracket or exciter, damaged exciter, sensor is not properly adjusted or has worn cable insulation, or worn sensor block clip, wheel bearing failure, wheel bearing is not properly adjusted (these faults will only occur at speeds greater than 6 mph).</p> <p>Measure the AC voltage at the sensor in question while rotating the wheel at a rate of about one revolution every two seconds. The output should be at least 200 millivolts (0.2 VAC).</p> <p>If this is not the case, push in the sensor until it touches the exciter and rotate the wheel again. If this doesn't correct the problem, then the sensor should be replaced.</p> <p>Verify tire and wheel size is large enough for 100 tooth exciter ring. If these faults re-occur at the same speed, inspect exciter ring for damage.</p> <p>Smaller wheels and tires require 80 tooth exciter rings. Reference Tire Scale Factor Chart.</p> <p>Verify sensor and valve wiring/plumbing is correct.</p> <p>See side by side and axle by axle configurations</p>	X	
22	Red channel wheel speed sensor S1B has an erratic output voltage.		X	
23	Blue channel wheel speed sensor S2A has an erratic output voltage.			X
24	Yellow channel wheel speed sensor S2B has an erratic output voltage.			X
25	Blue channel wheel speed sensor S3A has an erratic output voltage.			X
26	Yellow channel wheel speed sensor S3B has an erratic output voltage.			X

Occurs only when vehicle is stationary

31	Auxiliary channel 1 fault (digital channel 1) output only	<p>PLC Select 2M Plus (ABS Auxiliary Codes)</p> <p>Note: These Codes are only used with PLC Select 2M Plus ABS that supports trailer Auxiliaries</p> <p>Auxiliary Channel has an open circuit or the ECU (Electronic Control Unit) has auxiliary device connected and is not programmed to be.</p> <p>Note: These codes do not affect ABS performance and do not illuminate the tractor or trailer ABS warning lamps</p>		
32	Auxiliary channel 2 fault (digital channel 2) output only			
33	Auxiliary channel 3 fault (digital channel 3) input only			
34	Auxiliary channel 4 fault (digital/analog channel 1) input only			
35	Auxiliary channel 5 fault (digital/analog channel 2) input only			



Troubleshooting PLC Select 1M / 2M Diagnostics Codes

Code	<i>Explanation:</i>	<i>Possible Causes:</i>	PLC Select 1M	PLC Select 2M
41	Slow wheel recovery on Red valve channel.	For a 2M System, verify sensor and valve wiring/plumbing is correct. (See Side-By-Side and Axle-By-Axle configurations). Slow brake release, foundation brake mechanical faults, dry bushings, broken ABS valve, restricted piping. Check for kinks and blockage etc. Incorrect air-lines, wiring.	X	
42	Slow wheel recovery on Blue valve channel.			X
43	Slow wheel recovery on Yellow valve channel.			X
61	Hold solenoid Open circuit on Red valve channel.	Modulator valve solenoid failure, solenoid connection, or valve cable damage. The most likely causes include: a bad solenoid or a loose solenoid connection. Disconnect the indicated solenoid and check the resistance at the solenoid pins.	X	
62	Hold solenoid Open circuit on Blue valve channel.			X
63	Hold solenoid Open circuit on Yellow valve channel.			X
67	Dump solenoid Open circuit on Red valve channel.	Check the female terminals on the connector for excessive pin spread or corrosion. Replace defective hardware as required and retest. Refer to solenoid page (Page 55)	X	
68	Dump solenoid Open circuit on Blue valve channel.			X
69	Dump solenoid Open circuit on Yellow valve channel.			X
71	Hold solenoid Short circuit to ground on Red valve channel.	Modulator valve solenoid failure, or valve cable damage. The most likely causes include: a damaged cable or solenoid. An example of this is a worn or chafed cable that has exposed wires contacting the trailer.	X	
72	Hold solenoid Short circuit to ground on Blue valve channel.			X
73	Hold solenoid Short circuit to ground on Yellow valve channel.			X
77	Dump solenoid Short circuit to ground on Red valve channel	Disconnect the indicated solenoid and check the resistance at the solenoid pins. Refer to solenoid page (Page 55)	X	
78	Dump solenoid Short circuit to ground on Blue valve channel			X
79	Dump solenoid Short circuit to ground on Yellow valve channel			X

Troubleshooting PLC Select 1M / 2M

Diagnostics Codes



Fault Code	<i>Explanation:</i>	<i>Possible Causes:</i>	PLC Select 1M	PLC Select 2M
80	Output leakage or poor insulation on any of the valve channels.	<p>Modulator valve solenoid failure or valve cable damage. Indicates that the solenoid or its cable has a short circuit to positive power (12 volts DC). The most likely cause is a damage cable or solenoid. Disconnect the indicated solenoid and check the resistance at the solenoid pins.</p> <p>Refer to solenoid page (Page 54) for proper settings</p> <p>If solenoid checks good and 80-89 code still exists, check ECU.</p>	X	X
81	Hold solenoid short circuit to Permanent Power on Red valve channel.		X	
82	Hold solenoid short circuit to Permanent Power on Blue valve channel.			X
83	Hold solenoid short circuit to Permanent Power on Yellow valve channel.			X
87	Dump solenoid out shorted on Permanent Power on Red valve channel.		X	
88	Dump solenoid out shorted on Permanent Power on Blue valve channel.			X
89	Dump solenoid out shorted on Permanent Power on Yellow valve channel.			X
90	Low supply voltage fault. This code is not stored in memory.	Verify 12 VDC power source. Do Not Use Battery Charger as Power Supply. ECU minimum operating voltage is 8.5 VDC.	X	X
91	No internal ABS ECU solenoid voltage available.	Verify permanent power is present.	X	X
92	Power input over voltage fault.	Verify 12 VDC power source. Do Not Use Battery Charger as Power Supply. ECU maximum operating voltage is 16.0 VDC.	X	X
93	Short circuit on ABS ECU internal relay.	Replace ECU	X	X
99	ABS Corrupt Memory.		X	X
9A	ABS Corrupt Memory.		X	X



Troubleshooting PLC Select 1M / 2M Diagnostics Codes

<i>Fault Code</i>	<i>Explanation:</i>	<i>Display Information</i>
-------------------	---------------------	----------------------------

Codes A(x) and C(x) displayed when power is applied to the ABS ECU. They should not be displayed for more than 2 seconds; if code remains permanently displayed, repair is necessary.

A7	Trailer: 2S/1M - SLH on Red channel 2S/2M, or 4S/2M - SLH on yellow channel	Programmed for tandem or multi-axle trailer. Displays current configuration.
A8	Trailer: 2S/1M - MSLH on Red Channel (dollies,steerable or single axle only)	Programmed for dollies, single or steer axle trailer. Displays current configuration.

Only display when viewing stored fault codes

CO	2S/1M configuration	S1A, S1B sensors, Red modulator. ECU is configured as a 2M and is powered up as a 1M. See "CC" cause below. Displays current configuration.
C1	2S/2M configuration	S2A, S2B sensors. Blue, Yellow modulator. ECU is configured as a 4S/2M and powered up as a 2S/2M. See "CC" cause below. Displays current configuration.
C2	4S/2M configuration information (not a fault code)	S3A, S2A, S2B, S3B sensors. Blue, Yellow modulators. Displays current configuration.
C3	4S/2M configuration information (not a fault code)	S3A, S2A, S2B, S3B sensors. Blue, Yellow modulators. (S3A and S3B sensed lift axle). Displays current configuration.
CA	Clear all (fault codes).	Occurs when clearing fault codes with the Info Center.
CC	Clear configuration	Only required when configured ABS System from a 4S/2M to a 2S/2M or any 2M configured to a 1M. Clear fault codes 3 times the with uninterrupted power to reconfigure
CF	Configuration fault?	Unrecognized ABS configuration. Verify all sensors and valve connections are correct. Verify sufficient power.

E(x) Codes	E0 thru EF are generated when internal problems exist within the ABS ECU	ABS ECU is defective. Replace the ABS ECU
---------------	--	---

Old Style Solenoid (Pre-DIN)

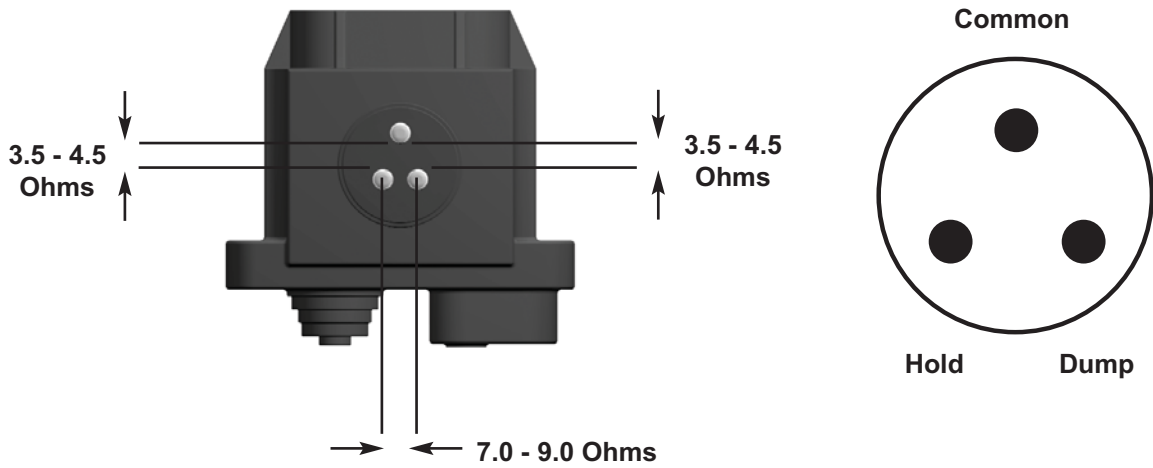

New Style Solenoid (DIN)
September 2009 - Present

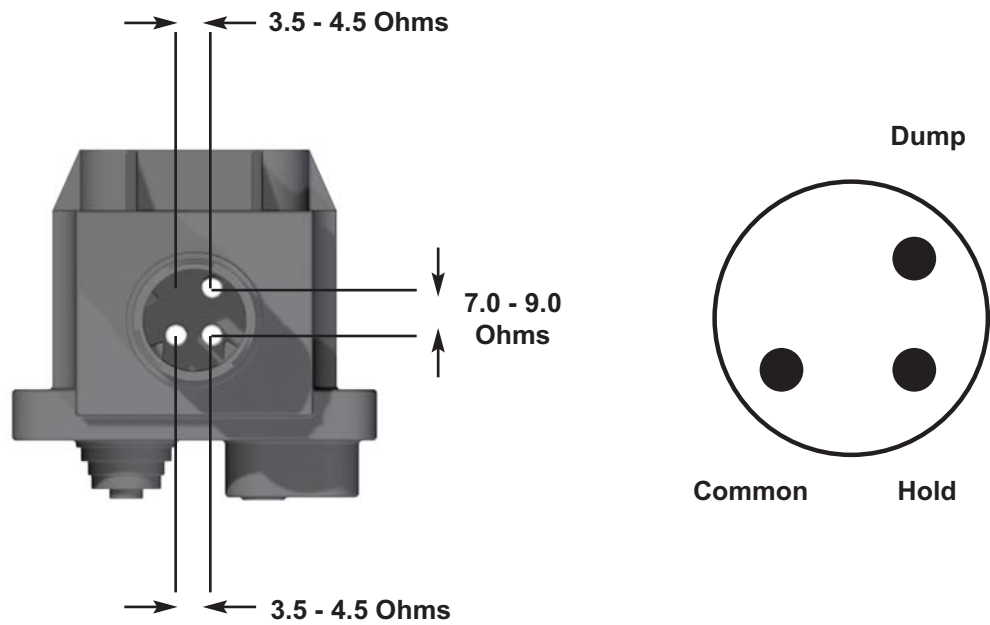

Haldex offers proprietary vehicle technology solutions to the global vehicle industry within specific niches. We focus on products to improve safety, the environment and vehicle dynamics.

We are enhancing our competitive capabilities and building long-term customer relationships through high performance, low total costs to the customer through the product's service life, ethical business practices and commitment to long-term partnerships. Haldex operations are divided into three business areas: Commercial Vehicle Systems, Hydraulic Systems and Traction Systems.

Warning: The products described within this literature, including without limitation, product features, specifications, designs, availability and pricing are subject to change by Haldex and its subsidiaries at any time without notice.

This document and other information from Haldex, its subsidiaries and authorized distributors provide product and/or system options for further investigation by users having technical expertise. It is important that you analyze all aspects of your application and review the information concerning the product or system, in the current literature or catalog. Due to the variety of operating conditions and applications for these products or systems, the user, through their own analysis and testing, is solely responsible for making the final selection of the products and systems and assuring that all performance, safety and warning requirements are met.

©2009, Haldex AB - This material may contain Haldex trademarks and third party trademarks, trade names, corporate logos, graphics and emblems which are the property of their respective companies. The contents of this document may not be copied, distributed, adapted or displayed for commercial purposes or otherwise without prior written consent from Haldex.

Austria

Haldex Wien Ges.m.b.H.
Vienna
Tel.: +43 1 8 65 16 40
Fax: +43 1 8 65 16 40 27
E-Mail: info.AT@Haldex.com

Belgium

Haldex N.V./S.A.
Balegem (Ghent)
Tel.: +32 9 363 90 00
Fax: +32 9 363 90 09
E-Mail: info.BE@Haldex.com

Brazil

Haldex do Brasil Ind. e Com, Ltda.
São Paulo
Tel.: +55 11 213 55 000
Fax: +55 11 503 49 515
E-Mail: info.BR@Haldex.com

Canada

Haldex Ltd
Guelph, Ontario
Tel.: +1 519 826 7723
Fax :+1 519 826 9497
E-Mail: info.CA@Haldex.com

China

Haldex International Trading Co. Ltd.
Shanghai
Tel.: +86 21 5240 0338
Fax: +86 21 5240 0177
E-Mail: info.CN@Haldex.com

France

Haldex Europe SAS
Weyersheim (Strasbourg)
Tel.: +33 3 88 68 22 00
Fax: +33 3 88 68 22 09
E-Mail: info.EUR@Haldex.com

Germany

Haldex Brake Products GmbH
Heidelberg
Tel.: +49 6221 7030
Fax: +49 6221 703400
E-Mail: info.DE@Haldex.com

Hungary

Haldex Hungary Kft.
Szentlőrincváta
Tel.: +36 29 631 300
Fax: +36 29 631 301
E-Mail: info.HU@Haldex.com

India

Haldex India Limited
Nasik
Tel.: +91 253 2380094
Fax +91 253 2380729
E-Mail: info.IN@Haldex.com

Italy

Haldex Italia Srl.
Biassono
Tel.: +039 47 17 02
Fax: +039 27 54 309
E-Mail: info.IT@Haldex.com

Mexico

Haldex de Mexico S.A. De C.V.
Monterrey
Tel.: +52 81 8156 9500
Fax: +52 81 8313 7090

Poland

Haldex Sp. z.o.o.
Praszka
Tel.: +48 34 350 11 00
Fax: +48 34 350 11 11
E-Mail: info.PL@Haldex.com

Russia

OOO Haldex RUS
Moscow
Tel.: + 7 495 747 59 56
Fax: +7 495 786 39 70
E-Mail: info.RU@Haldex.com

South Korea

Haldex Korea Ltd.
Seoul
Tel.: +82 2 2636 7545
Fax: +82 2 2636 7548
E-Mail: info.KR@Haldex.com

Spain

Haldex España S.A.
Parets del Valles (Barcelona)
Tel.: +34 93 573 10 30
Fax: +34 93 573 07 28
E-Mail: info.ES@Haldex.com

Sweden

Haldex Brake Products AB
Landskrona
Tel.: +46 418 47 60 00
Fax: +46 418 47 60 01
E-Mail: info.SE@Haldex.com

United Kingdom

Haldex Ltd.
Newton Aycliffe
Tel.: +44 1325 310 110
Fax: +44 1325 311 834
E-Mail: info.GBAy@Haldex.com

Haldex Brake Products Ltd.

Redditch
Tel.: +44 1527 499 499
Fax: +44 1527 499 500
E-Mail: info.GBRe@Haldex.com

USA

Haldex Brake Products Corp.
Kansas City, MO
Tel.: +1 816 891 2470
Fax: +1 816 891 9447
E-Mail: info.US@Haldex.com

