



Service Data

SD-03-2501

Bendix® DV-2™ Automatic Reservoir Drain Valve



STANDARD DV-2™ VALVE

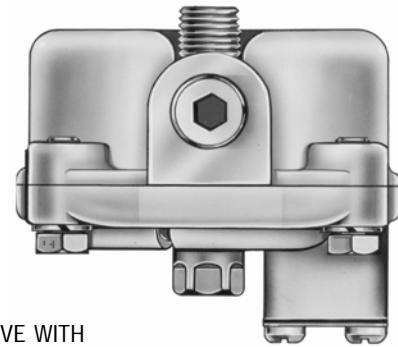

DV-2™ VALVE WITH HEATER

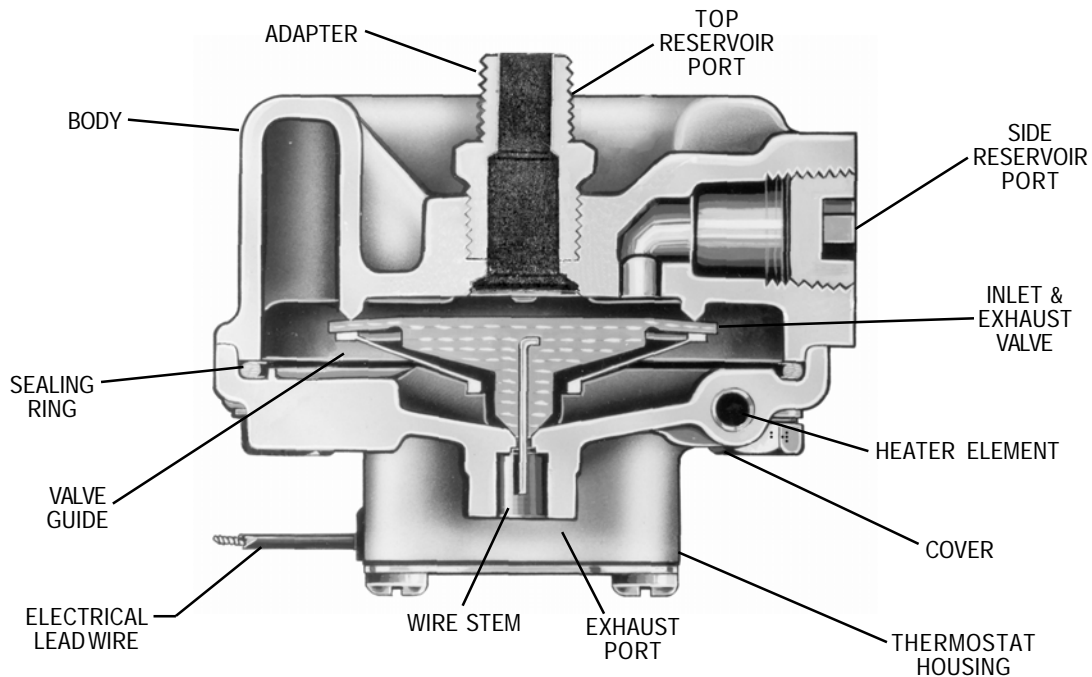

DV-2™ VALVE WITH HEATER AND THERMOSTAT

DESCRIPTION

The DV-2™ automatic reservoir drain valve ejects moisture and contaminants from the reservoir in which it is connected. It operates automatically and requires no manual assistance or control lines from other sources.

The automatic reservoir drain valve has a die cast aluminum body and cover and is normally mounted either in the bottom of the reservoir using the top port of the drain valve or in the end of an end drain reservoir using the side port of the valve.

The DV-2™ valve is also available with a heater and thermostat cast into the cover for vehicles operated in subfreezing temperatures. The heated DV-2™ valve is supplied in either a 12 or 24 volt model and in bottom or end drain configuration. A 1/4" male pipe adapter is supplied with all DV-2™ drain valves, end drain and bottom drain, both standard and heated. This adapter should be installed directly into the reservoir. Early versions included a filter screen in the adapter. The filter should be discarded. Later versions may have a standard pipe nipple instead of the adapter.

NOTE: If a vehicle equipped with a DV-2™ automatic drain valve(s) is operated in subfreezing temperatures, it is recommended that a heated reservoir drain valve is installed.

OPERATION

Referring to Figure 1, with no air pressure in the system, the inlet and exhaust valves are closed. Upon charging the system, a slight pressure opens the inlet valve (Figure 2) which permits air and contaminants to collect in the sump. The inlet valve remains open when pressure is ascending in the system until maximum (governor cutout) pressure is reached. The spring action of the valve guide in the sump cavity closes the inlet valve. The inlet valve and the exhaust valve are now closed (Figure 3).

When reservoir pressure drops slightly (approximately 2 psi), air pressure in the sump cavity opens the exhaust valve (Figure 4) and allows moisture and contaminants to be ejected from the sump cavity until pressure in the sump cavity drops sufficiently to close the exhaust valve.

The length of time the exhaust valve remains open and the amount of moisture and contaminants ejected depends upon the sump pressure and the reservoir pressure drop that occurs each time air is used from the system.

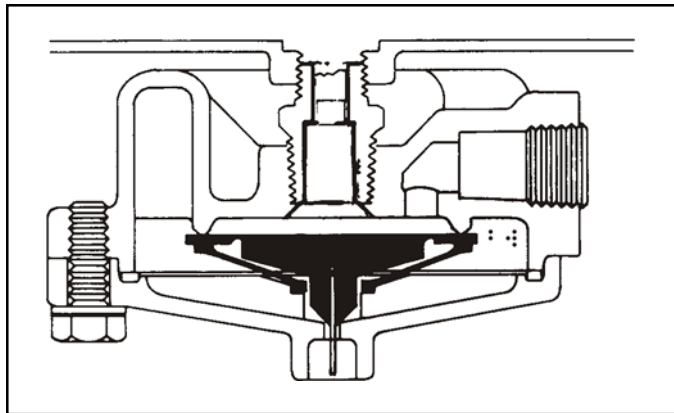

FIGURE 1

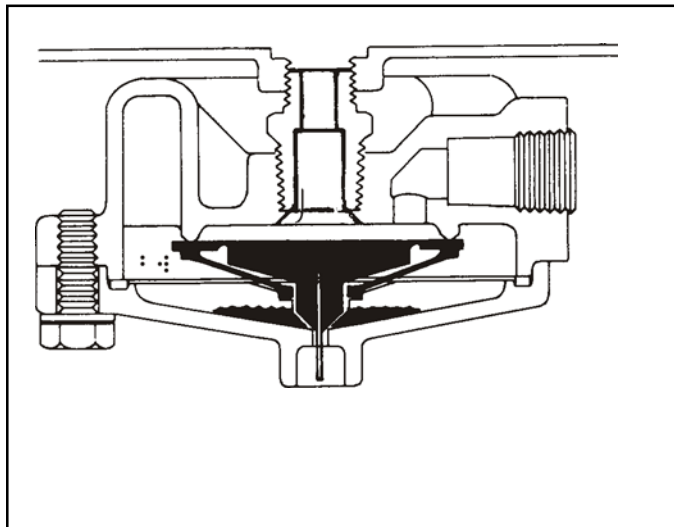

FIGURE 3

Manual draining can be accomplished as follows:

Using a tool, move the wire in the exhaust port upward, holding it in until draining is completed.

The thermostat on the heated model DV-2™ automatic drain valve will activate the heating element when the valve body reaches a temperature of approximately 45°F and will deactivate the heating element when the valve body is warmed to approximately 85°F.

PREVENTIVE MAINTENANCE

Important: Review the Bendix Warranty Policy before performing any intrusive maintenance procedures. A warranty may be voided if intrusive maintenance is performed during the warranty period.

No two vehicles operate under identical conditions, as a result, maintenance intervals may vary. Experience is a valuable guide in determining the best maintenance interval for air brake system components. At a minimum, the automatic reservoir drain valve should be inspected every 6 months or 1500 operating hours, whichever comes first, for proper operation. Should the automatic reservoir drain valve not meet the elements of the operational tests noted in this document, further investigation and service of the valve may be required.

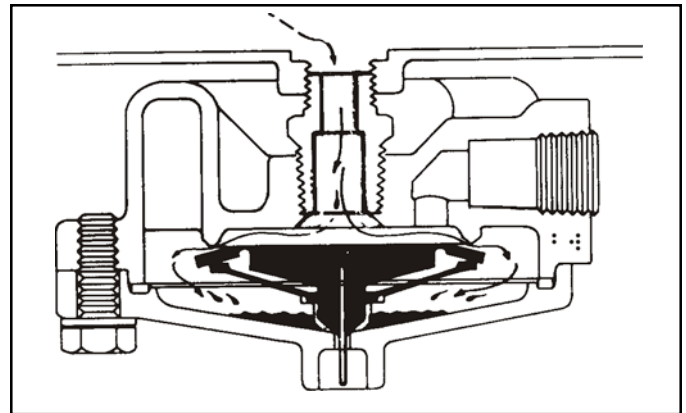

FIGURE 2

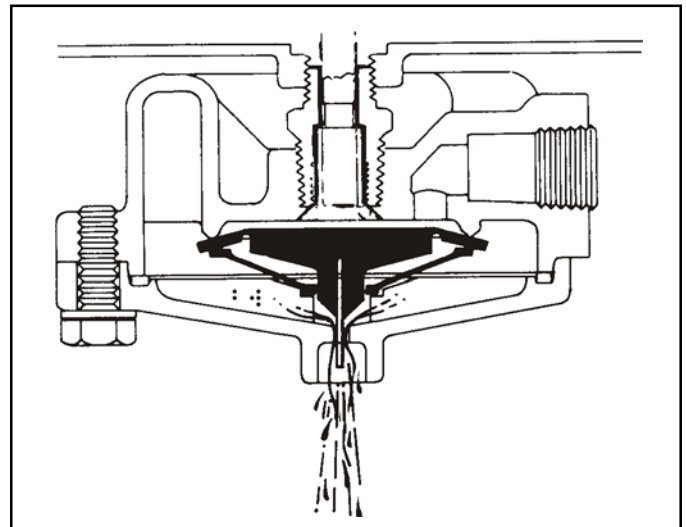

FIGURE 4

Upon investigation, parts showing signs of wear or deterioration should be replaced.

If there is a filter screen in the adapter fitting it should be removed and discarded.

SERVICE CHECKS

OPERATING TEST

With system charged, make several foot valve applications and note each time an application is made, an exhaust of air occurs at the exhaust port of the drain valve. If no air comes out, push the wire stem. If no air comes out, there may be a plugged filter in the adapter which should be removed and discarded.

LEAKAGE TEST

With system charged and pressure stabilized in system, there should be no leaks at the drain valve exhaust. A constant slight exhaust of air at the drain valve exhaust could be caused by excessive leakage in the air brake system.

If the DV-2™ automatic drain valve does not function as described or if leakage is excessive, it is recommended that it be replaced with a new or remanufactured unit or repaired with genuine Bendix parts.

INSTALLING AND REMOVING

REMOVING

Block and hold vehicle by means other than air brakes. Drain air system.

Disconnect heater wire if valve is so equipped. Remove automatic reservoir drain valve.

DISASSEMBLY

Remove 4 cap screws and lock washers. Remove cover and sealing ring.

NOTE: The heater and thermostat of the DV-2™ valve's so equipped are not serviceable. If the heater or thermostat has failed, the entire cover must be replaced. Do not remove the thermostat cover plate. It is moisture sealed and removal could result in early thermostat failure.

Remove valve guide.

Remove inlet and exhaust valve.

Remove adapter and filter assembly (if filter present).

Remove filter retainer (if any).

Remove filter (if any).

INSTALLING

Block and hold vehicle by means other than air brakes. Drain air system.

To avoid early fouling at the DV-2™ valve, thoroughly finish and clean the reservoir before installing the drain valve.

Aerate any tank thoroughly if any solvents have been used in the cleaning process.

IMPORTANT

When installing a DV-2™ drain valve equipped with a heater and thermostat, first determine if the vehicle electrical system is 12 or 24 volt, and that the heater/thermostat unit is of the same voltage. The #14 gauge lead wire on the valve should be connected to the "on" position of the engine control or ignition switch. Use an 8 amp fuse for one valve, a 15 amp fuse for two valves, and a 20 amp fuse for three valves. All electrical connections must be waterproof.

CLEANING AND INSPECTION

Cleaning solvent may be used on metal parts. Rubber parts should be wiped clean.

Inspect all parts for wear or deterioration. Discard filter screen if present.

Replace all parts not considered serviceable during these inspections.

Bendix Field Maintenance Kit 282134 contains all parts necessary for servicing all models of the DV-2™ valve.

ASSEMBLY

Before assembling the valve, apply a light film of grease on inlet valve seat.

DO NOT APPLY OIL TO THE INLET AND EXHAUST VALVE.

Place sealing ring in groove of cover.

Place valve guide over inlet and exhaust valve.

Place valve guide and inlet and exhaust assembly into cover (wire will project through exhaust port).

Place body on cover and install cap screws and lockwashers. Install adapter or pipe nipple in appropriate port.

Install drain valve in reservoir and reconnect heater wire if drain valve is so equipped.

NOTE: Covers on the standard and heated drain valves can be interchanged.

TESTING REBUILT AUTOMATIC RESERVOIR DRAIN VALVE

Perform "Operating and Leakage Checks" as outlined in this section.

GENERAL SAFETY GUIDELINES

WARNING! PLEASE READ AND FOLLOW THESE INSTRUCTIONS TO AVOID PERSONAL INJURY OR DEATH:

When working on or around a vehicle, the following general precautions should be observed at all times.

1. Park the vehicle on a level surface, apply the parking brakes, and always block the wheels. Always wear safety glasses.
2. Stop the engine and remove ignition key when working under or around the vehicle. When working in the engine compartment, the engine should be shut off and the ignition key should be removed. Where circumstances require that the engine be in operation, **EXTREME CAUTION** should be used to prevent personal injury resulting from contact with moving, rotating, leaking, heated or electrically charged components.
3. Do not attempt to install, remove, disassemble or assemble a component until you have read and thoroughly understand the recommended procedures. Use only the proper tools and observe all precautions pertaining to use of those tools.
4. If the work is being performed on the vehicle's air brake system, or any auxiliary pressurized air systems, make certain to drain the air pressure from all reservoirs before beginning **ANY** work on the vehicle. If the vehicle is equipped with an AD-IS® air dryer system or a dryer reservoir module, be sure to drain the purge reservoir.
5. Following the vehicle manufacturer's recommended procedures, deactivate the electrical system in a manner that safely removes all electrical power from the vehicle.
6. Never exceed manufacturer's recommended pressures.
7. Never connect or disconnect a hose or line containing pressure; it may whip. Never remove a component or plug unless you are certain all system pressure has been depleted.
8. Use only genuine Bendix® replacement parts, components and kits. Replacement hardware, tubing, hose, fittings, etc. must be of equivalent size, type and strength as original equipment and be designed specifically for such applications and systems.
9. Components with stripped threads or damaged parts should be replaced rather than repaired. Do not attempt repairs requiring machining or welding unless specifically stated and approved by the vehicle and component manufacturer.
10. Prior to returning the vehicle to service, make certain all components and systems are restored to their proper operating condition.
11. For vehicles with Antilock Traction Control (ATC), the ATC function must be disabled (ATC indicator lamp should be ON) prior to performing any vehicle maintenance where one or more wheels on a drive axle are lifted off the ground and moving.

