

# Typical Truck System Schematic with ESP® Stability

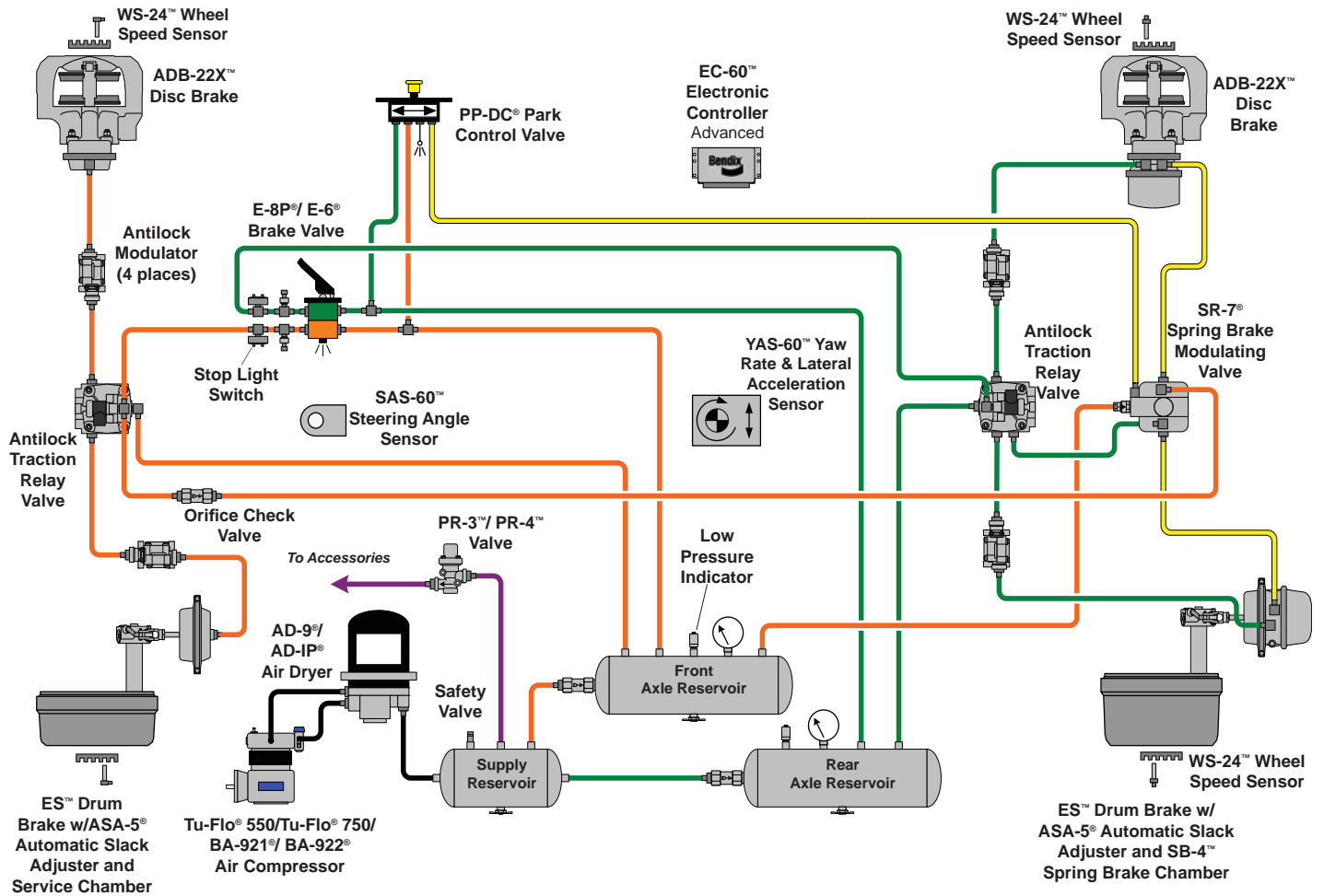

**Notes:**  
 The color coding of the brake system schematic follows TMC Recommended Practice #423.  
 Air disc & drum brake actuation combined on a single axle are shown for pictorial purposes only.

TRUCKS AND TRUCK TRACTORS:					
Charging	Primary	Secondary	Park (Supply)	Parking (Control)	Accessories