

SPRING BRAKE CONTROL VALVES

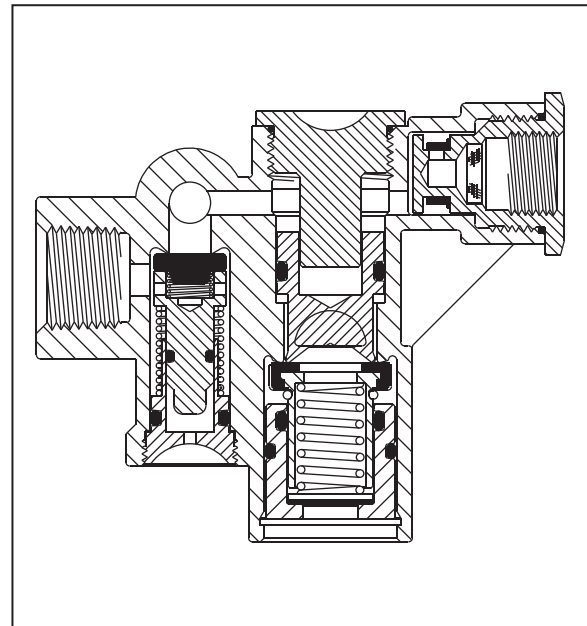

Spring Brake Control Valve – Service Reservoir Priority

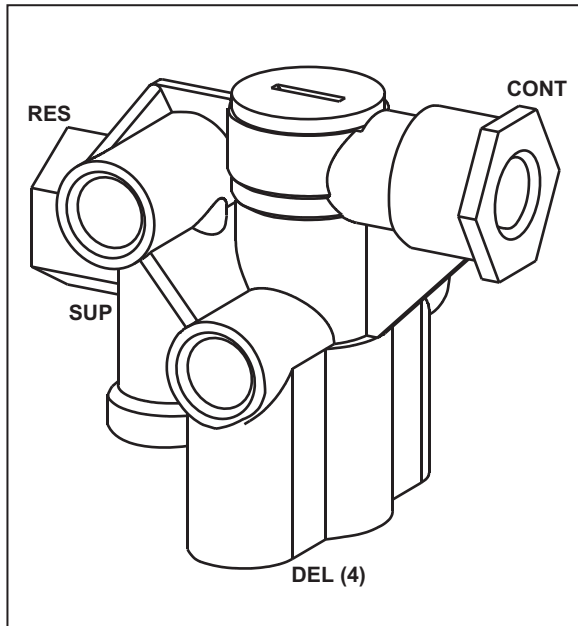

INFORMATION:

- The service reservoir priority provides supply air to simultaneously fill the reservoir & release the spring brakes after the internal Pressure Protection Valve opens at approximately 80 psi
- Complies with all changes to FMVSS 121, Docket 90-3 effective October 8, 1992
- Designed for use with a single reservoir on a typical single or tandem axle trailer
- May also be used with two 1,400 cubic inch (nominal) reservoirs on tandem axle trailers
- Mounting Hardware on pages 61 & 62
- Piping examples on pages 71, 72, 74, 75 & 76
- **PLUG UNIT ASSEMBLY 110705** for movable seat
- **PLUG UNIT ASSEMBLY 110515** for pressure protection

PART NUMBER	PORT SIZES (NPT)			
	Supply	Control	Reservoir	Delivery (4)
110700	3/8"	3/8"	1/2"	3/8"