

SPRING BRAKE CONTROL VALVES

Spring Brake Control Valves – Spring Brake Priority

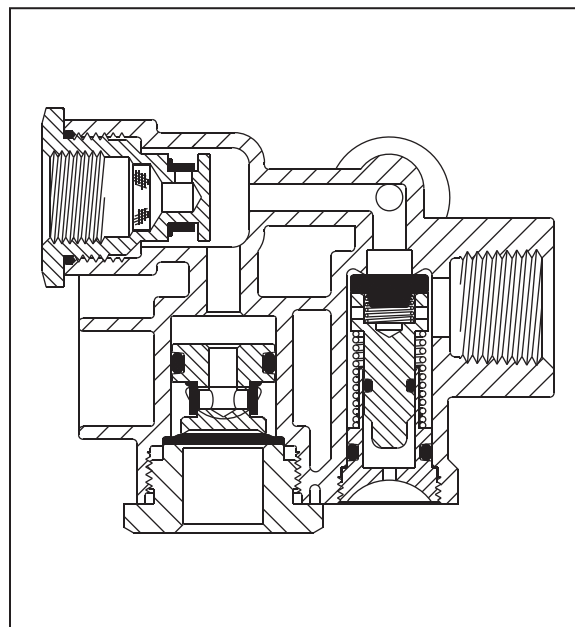
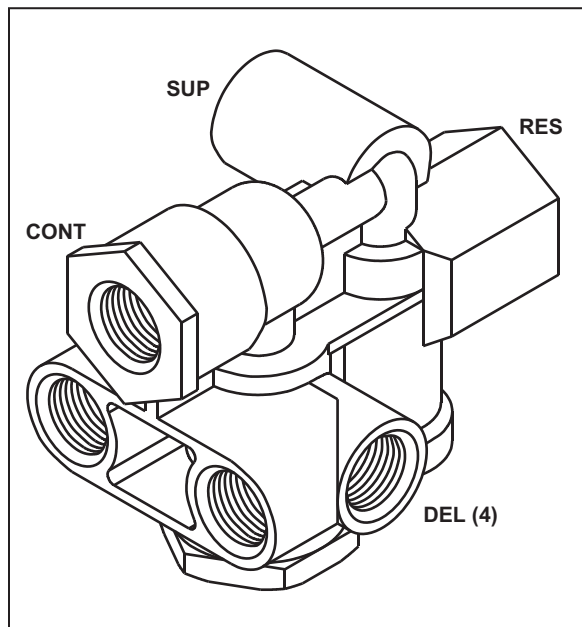

INFORMATION:

- The spring brake priority immediately provides supply air to release the spring brakes, the internal Pressure Protection Valve opens to also fill the reservoir at approximately 80 psi
- Complies with all changes to FMVSS 121, Docket 90-3 effective October 8, 1992
- Designed for use with a single reservoir on a typical single or tandem axle trailer
- May also be used with two 1,400 cubic inch (nominal) reservoirs on tandem axle trailers
- Mounting Hardware on pages 61 & 62
- Piping examples on pages 71, 72, 74, 75 & 76
- **PLUG UNIT ASSEMBLY 110515** for pressure protection
- **PLUG UNIT ASSEMBLY 110520** for movable seat
- **REPAIR KIT 110501**

PART NUMBER	PORT SIZES (NPT)				COMMENTS
	Supply	Control	Reservoir	Delivery (4)	
110500	3/8"	3/8"	1/2"	3/8"	None
110505	3/8"	3/8"	1/2"	3/8"	Delivery Back Ports B plugged
110510	3/8"	3/8"	1/2"	3/8"	Delivery Side Ports A plugged